

**Argus™ FK75C
Metal Seated,
Floating Ball Valve**

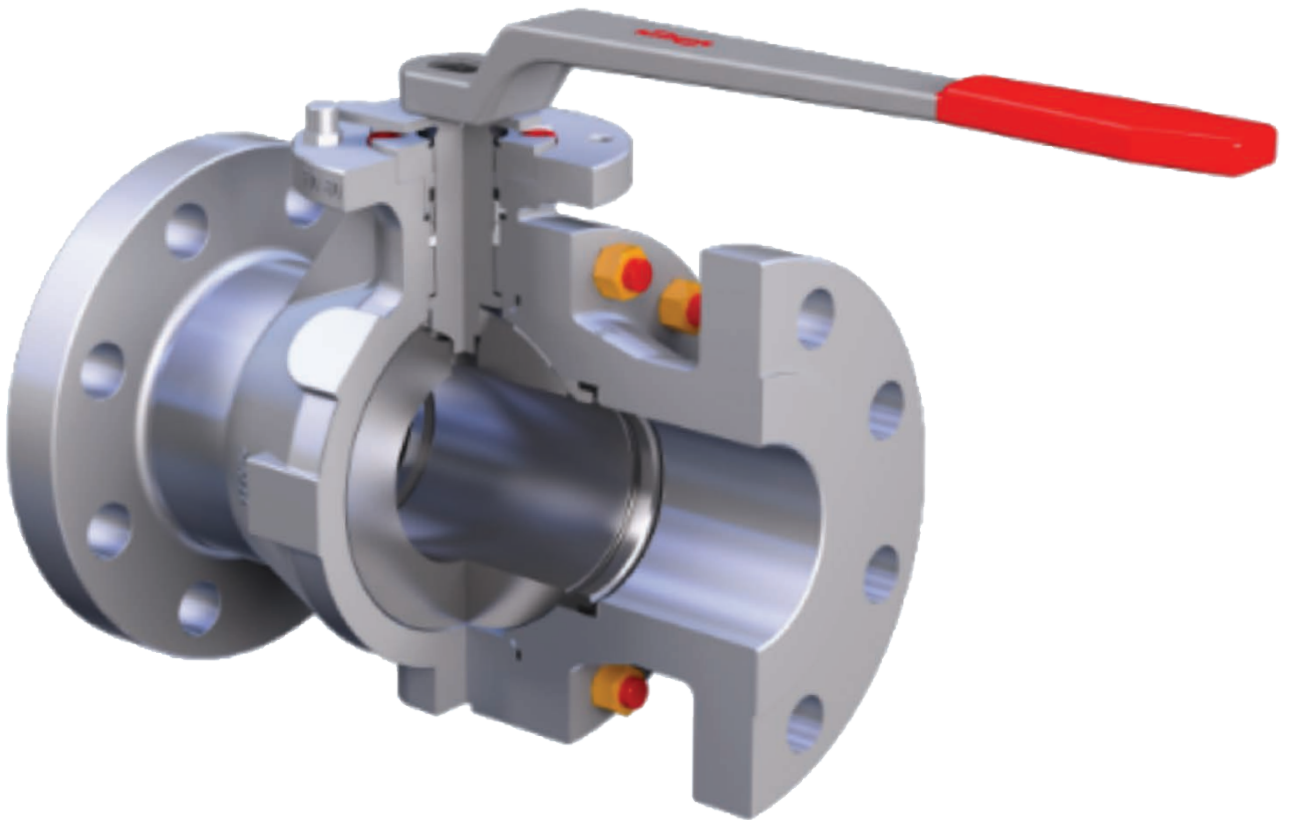

Built to the highest standards

The FK75C split-body, full-bore, floating ball valve represents the highest standards in valve technology. Its superfine-finished, seat-supported ball is just one of its many important design features. Others include an anti-blow out stem, long-life, double-stem seal system and stem supported in bearings to ensure seals are free from operation loads.

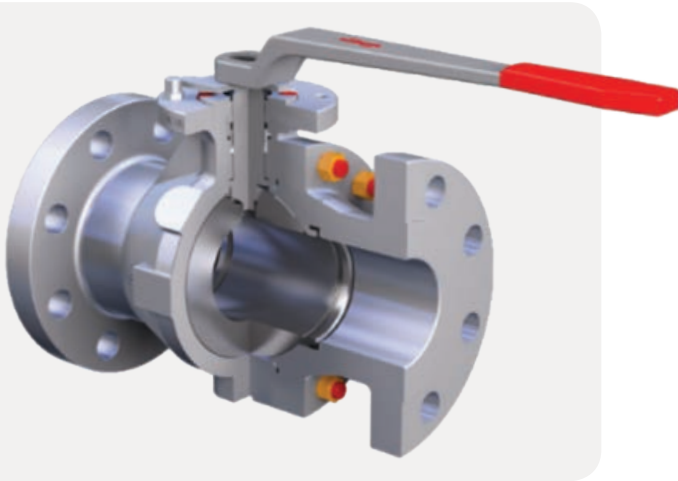

Technical design features

- Sizes: NPS 3 – 4 in; DN 80 – 100
- ASME pressure classes: Class 150 – 300
- Valve maximum temperature: 250°C (482°F)
- Designed to: ASME B16.34 (PED 97/23/EC optional)
- Materials: ASME Section II
- Pressure/temperature rating: ASME B16.34/B16.5
- Wall thickness: ASME B16.34
- Face-to-face dimensions: ASME B16.10
- Flange connection/end type: ASME B16.5
- Fire-safe: ISO 10497
- Bi-directional, metal-to-metal sealing: ANSI B16.104, FCI 70-2 class V
- Stem sealing system: EN ISO 15848-1
- Anti-static design: DIN EN ISO 17292, chapter 5.2.7

Materials

Description	NPS 3 – 4 in ASTM Material	DN 80 – 100 in Material DIN EN
Body	A352 Gr. LCB	LCS casting DIN EN 1.6220
	A351 Gr. CF8M	SS DIN EN 1.4408
Ball	A351 CF8M chrome plated	SS DIN 1.4408 chrome plated
Stem	A182 F51	Duplex DIN EN 1.4462
Seats	ASTM A182 F51 Crabide HVOF	Duplex DIN 1.4462 Crabide HVOF
Stem seals	Graphite	
Body seals	Spiral-wound gasket A316L/graphite	
Bolts	A193 B7; A193 B8M CL2	
Nuts	A194 Grs. 4, 7 or 8M	

Metal coatings

Chrome hardplated (ball)

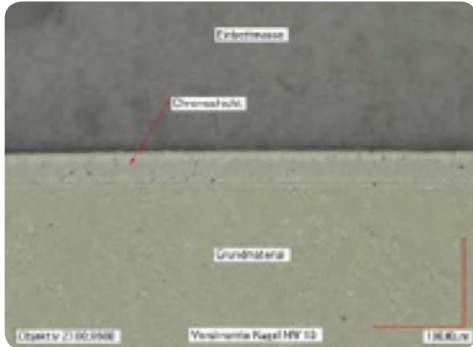

Basis	Chromium
Hardness	900 – 1100 HV0,3 (>67 HRC)
Temperature limit	Max. 350°C (662°F) (depending on base material and process conditions)
Thickness	>30 – 50 µm (average)
Chemical properties	High chemical resistance as well as under high temperature
Mechanical properties	High resistance against abrasion and adhesive wear

- Einbettmasse = embedding compound
- Chromschicht = chromium coating
- Grundmaterial = base material

Crabide (seats)

Crabide is a hard metal alloy based on chromium-carbide and nickel/chromium.

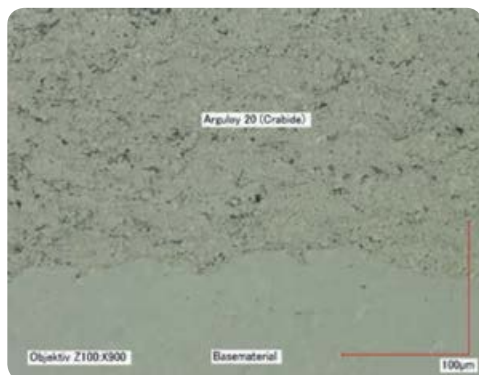

Composition	$Cr_2C_2/Ni-Cr$ 75/25
Hardness	900 – 1100 HV0,3 (>67 HRC)
Temperature limit	Max. 660°C (1112°F) (depending on base material and process conditions)
Thickness	200 – 300 µm (usual)
Chemical properties	Resistance versus media in the range of pH 5 to pH 12, as well under high-temperature conditions
Mechanical properties	High resistance, especially against abrasion and adhesive wear and sliding abrasion

Sectional drawing

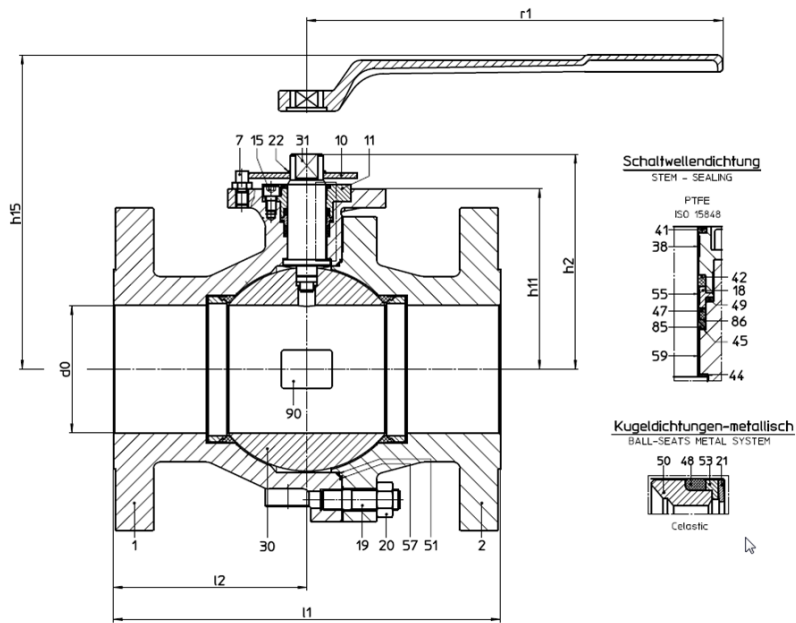

Dimensions

ASME Class 150 mm (in)

DN (NPS)	Flange/End Type	l1	l2	h2	h11	h15	r1	d0	Topwork DIN/ISO 5211
80 (3)	RF	203 (8.00)	100 (3.94)	153 (6.02)	126 (4.96)	182 (7.16)	327.5 (12.90)	75 (2.95)	F10
100 (4)	RF	229 (9.00)	100 (3.94)	169 (6.64)	142 (5.59)	198 (7.79)	327.5 (12.90)	100 (3.94)	F10

ASME Class 300 mm (in)

DN (NPS)	Flange/End Type	l1	l2	h2	h11	h15	Sr1	d0	Topwork DIN/ISO 5211
80 (3)	RF	283 (11.13)	142 (5.59)	153 (6.02)	126 (4.96)	182 (7.16)	327.5 (12.90)	75 (2.95)	F10
100 (4)	RF	305 (12.00)	152.5 (6.00)	169 (6.65)	142 (5.59)	198 (7.79)	327.5 (12.90)	100 (3.94)	F10

Pressure/temperature rating per ASME B16.34

Temperature, °F	A352 Gr. LCB		A351 Gr. CF8M	
	Working Pressures by Class, psig		Working Pressures by Class, psig	
	Class 150	Class 300	Class 150	Class 300
-20 to 100	265	695	275	720
200	255	660	235	620
300	230	640	215	560
400	200	615	195	515
500	170	585	170	480

Temperature, °C	A352 Gr. LCB		A351 Gr. CF8M	
	Working Pressures by Class, bar		Working Pressures by Class, bar	
	Class 150	Class 300	Class 150	Class 300
-29 to 38	18.4	48.0	19.0	49.6
50	18.2	47.05	18.4	48.1
100	17.4	45.3	16.2	42.2
150	15.8	43.9	14.8	38.5
200	13.8	42.5	13.7	35.7
250	12.1	40.8	12.1	33.4

Part numbers

ASME Class 150

NPS	Class	Ends	Body	Sectional	Assembly	Topwork	DIN ISO	Valve number
3	150	RF	CS	4L8930	4L8924	3Z0424	F10	759305-ETG
4	150			4L8931	4L8926			759306-ETG
3	300			4L8930	4L8925			759309-ETG
4	300			4L8931	4L8927			759310-ETG
3	150		SS	4L8930	4L8924			759307-ETG
4	150			4L8931	4L8926			759308-ETG
3	300			4L8930	4L8925			759311-ETG
4	300			4L8931	4L8927			759312-ETG

Standard Topwork drawings

FK75C Topwork drawing 3Z0424

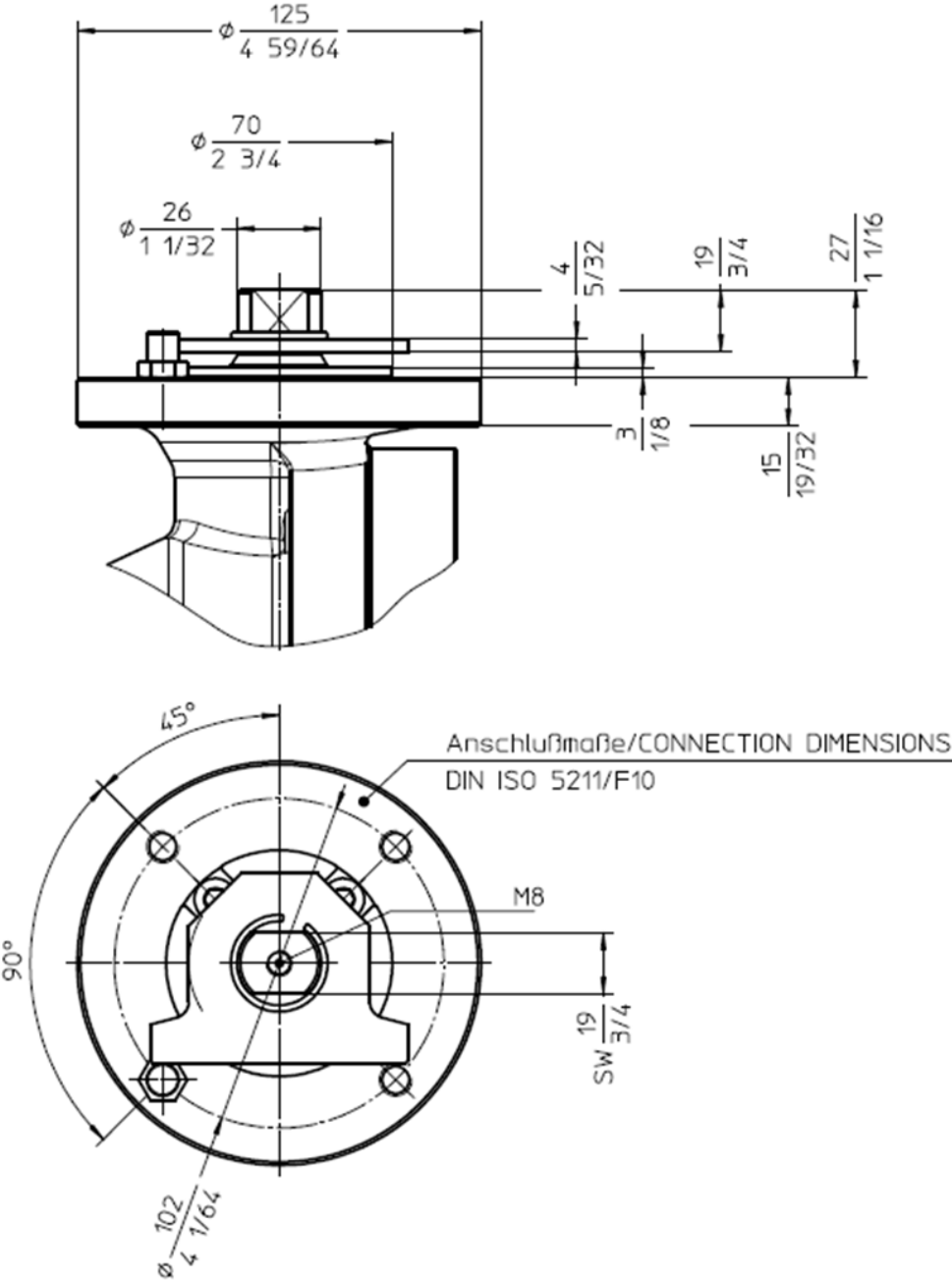

Torque tables

Pressure class: Class 150 and Class 300

Seat system: bidirectional "N"

Pressure (psi)	NPS 3 (lb-in)	NPS 4 (lb-in)
116	1017	1505
145	1177	1753
181	1381	2053
232	1664	2478
290	1983	2974
362	2390	3576
464	2956	4434
580	3602	5408
725	4416	6629

Pressure class: Class 150 and Class 300

Seat system: bidirectional "N"

Pressure (bar)	DN 80 (Nm)	DN 100 (Nm)
8	115	170
10	133	198
12.5	156	232
16	188	280
20	224	336
25	270	404
32	334	501
40	407	611
50	499	749

Values included

- Metal seated: Chrome/Crabiide
- Stem sealing system: ISO 15848-1

Additional multiplication factors

Application

- Daily operation: 1.0
- Operation after longer periods of disuse (≥ 2 days): 1.1
- Operation after longer periods of disuse (≥ 5 days): 1.2

Media

- Lubricating: 1.0
- Non-lubricating: 1.3

Example:

DN100/differential pressure 32 bar/operation every 3 days/
lubricating media

$$Md = 501 \text{ Nm} \times 1.1 \times 1.0 = 551 \text{ Nm}$$



USA

Headquarters

Flowserve Corporation
5215 North O'Connor Blvd.
Suite 2300
Irving, Texas 75039-5421 USA
Phone: +1 937 890 5839

Flowserve Corporation
3993 W. Sam Houston Parkway North
Suite 100
Houston, TX 77043
Phone: +1 281 469 4166

Flowserve Corporation
1978 Foreman Drive
Cookeville, TN 38501
Phone: +1 931 432 4021

Europe

Flowserve Flow Control GmbH
Rudolf-Plank-Straße 2
D-76275
Ettlingen, Germany
Phone: +49 7243 103-0
Fax: +49 7243 103-222

ARENTB0013-01 (AQ) January 2019

Flowserve Corporation has established industry leadership in the design and manufacture of its products. When properly selected, this Flowserve product is designed to perform its intended function safely during its useful life. However, the purchaser or user of Flowserve products should be aware that Flowserve products might be used in numerous applications under a wide variety of industrial service conditions. Although Flowserve can provide general guidelines, it cannot provide specific data and warnings for all possible applications. The purchaser/user must therefore assume the ultimate responsibility for the proper sizing and selection, installation, operation, and maintenance of Flowserve products. The purchaser/user should read and understand the Installation Instructions included with the product, and train its employees and contractors in the safe use of Flowserve products in connection with the specific application.

While the information and specifications contained in this literature are believed to be accurate, they are supplied for informative purposes only and should not be considered certified or as a guarantee of satisfactory results by reliance thereon. Nothing contained herein is to be construed as a warranty or guarantee, express or implied, regarding any matter with respect to this product. Because Flowserve is continually improving and upgrading its product design, the specifications, dimensions and information contained herein are subject to change without notice. Should any question arise concerning these provisions, the purchaser/user should contact Flowserve Corporation at any one of its worldwide operations or offices.

©2019 Flowserve Corporation. All rights reserved. This document contains registered and unregistered trademarks of Flowserve Corporation. Other company, product, or service names may be trademarks or service marks of their respective companies.