

**Installation, Operation Instructions and Maintenance
Safety Advice**

**ARGUS Metal Seat Ball Valve –
FK 75C and FK 76C**

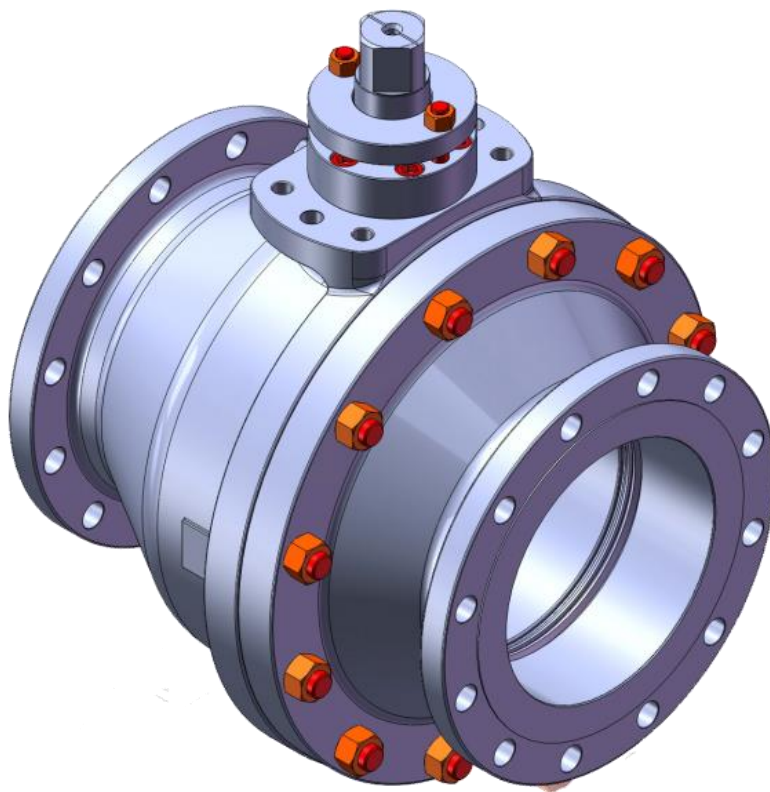

Original Installation and Operating Instruction
EN English

ARGUS

ARGUS Metal Seat Ball Valve Series FK 75C and FK 76C

Typical cut view of ARGUS FK 75C:

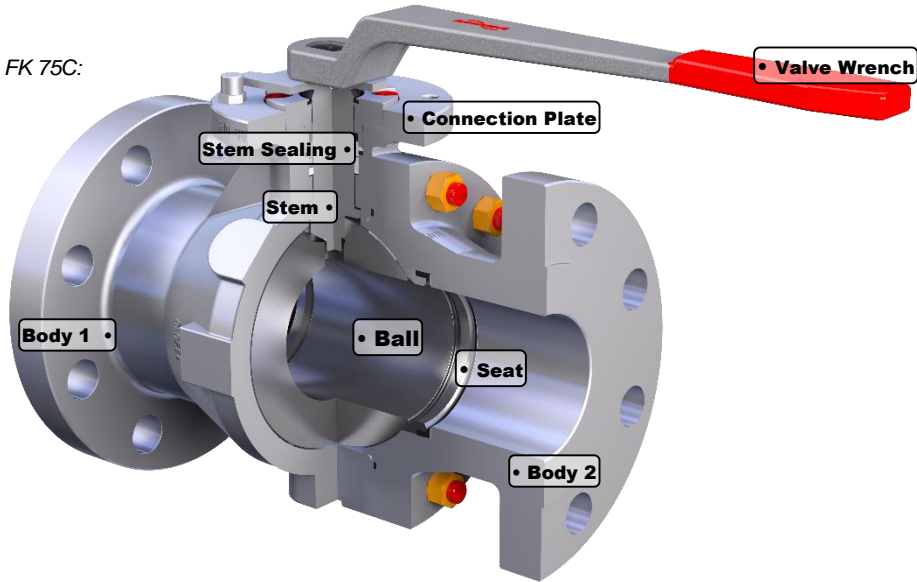

	FK 75C	FK 76C
Sizes	NPS 3"–4"	NPS 6"–12"
Design Standard	ASME B16.34	ASME B16.34
	Seat supported design	Trunnion mounted design
ASME Pressure Classes	Class 150–300 RF	Class 150–300 RF
Technical Design Features	Fire-safe according to ISO 10497	
	Bi-directional, metal to metal sealing, ANSI B16.104 FCI 70-2 class V	
	Anti-blow out stem, long life double-stem seal system and stem supported in bearings to ensure seals are free from operation loads	
	Stem sealing system according to EN ISO 15848	
	Anti-static design according to DIN EN ISO 17292, chapter 5.2.7	

	ASTM Material
Body	A352LCB
	A351 Gr.CF8M
Ball	A351 CF8M Chrome Plated (3"–8")
	A351 CF8M Carbide HVOF (10"–12")
Stem	A182 F51
Stem seals	Graphite
Seats	ASTM A182 F51 Carbide HVOF
Body seals	Spiral-wound-gasket A316L/Graphite
Bolts	A193 B7; A193 B8M CL2
Nuts	A194 Gr. 4; A194 Gr. 8M

For detail information, please contact your Flowserve representative or find the Technical Bulletins on www.flowserve.com.

ARGUS

Contents

1	General	5
1.1	These Instructions	5
1.2	Safety Relevant Marking on the Ball Valve	5
1.3	ARGUS Series FK 75C and FK 76C – Metal Seat Ball Valves	5
1.4	Customer Specification / Requisition – Inquiry and Order	5
1.5	Automated Ball Valve	5
2	Safety Information	6
2.1	Intended Use	6
2.2	Operating Limits of the Ball Valve – Refer to the Nameplate	6
2.3	Responsibility of Plant Engineering and Operation	6
2.4	Qualified Personnel for Installation and Operation	6
2.5	Safety Relevant Symbols	7
2.6	Ball Valve as Pressure Equipment	8
2.7	Use in Potentially Explosive Atmosphere	8
2.8	Automated Ball Valve – Safety Aspects	8
3	Delivery / Goods Receipt	9
3.1	Transportation	9
3.2	Goods Acceptance / Verification of the Delivery and Accompanying Documents	9
3.3	Unpacking / Transport to Storage Area	9
3.4	Identification of the Delivery	9
3.5	Storage	9
3.6	Transport to the Assembly and Utilization Site	9
4	Nameplate: Identification of the Ball Valve	10
5	Installation	11
5.1	Preparation for Installation	11
5.2	Installing Flange Connection	11
5.3	Actuator Mounting / Orientation of the Valve-Actuator Unit	13
6	Commissioning – Recommended Practice	14
6.1	Flushing and Pressure Testing the Pipework	14
6.2	Positions of the Ball Valve	14
7	Maintenance	16
7.1	Periodic Inspection	16
7.2	Exchanging Parts	16
7.3	Returning the Ball Valve: “Valve Information Sheet”	17
8	Decommissioning, De-Installation and Disposal	18
8.1	Decommissioning and De-Installation	18
8.2	Disposal	18
	FK 75C Disassembly / Assembly	19
	FK 76C Disassembly / Assembly	20
	Disclaimer	21

1 General

1.1 These Instructions

These "Installation and Operating Instructions" and Safety Advice are intended to provide relevant information to the qualified personnel entrusted with the use of ARGUS ball valve series **FK 75C** and **FK 76C** throughout the product lifecycle. The instructions should be kept close to the valve operating site or, if possible, close to the valves.

These instructions must be read prior to installing, commissioning, operating, using, maintaining, or decommissioning of the ball valves. They also provide information for secure transport and disposal.

Particular attention must be paid to all safety relevant information.

This manual applies to the intended use of all ball valves from the series with type designation **FK 75C** and **FK 76C** of the brand **ARGUS** as well for their special design variants. If necessary, additional important information is provided for special products, features and/or accessories.

For automated ball valves, this manual forms part of the comprehensive user documentation for the equipment. The instructions for all components must be observed.

All relevant regulations for occupational safety and health and for environmental protection – even if they are not explicitly stated in this manual – must be observed!

1.2 Safety Relevant Marking on the Ball Valve

As well as the instructions in this manual, safety relevant information on nameplate, additional plates or stamped directly on the valve must be observed.

Such marking must remain identifiable and legible.

1.3 ARGUS Series FK 75C and FK 76C – Metal Seat Ball Valves

The ARGUS series **FK 75C** and **FK 76C**, are highly performant Metal Seat Ball Valves. The series are designed, manufactured and qualified to cope with severe applications.

Design, material selection, accessories, and qualification of the valves are determined in accordance with the application requirements such as specified in a requisition, purchase order, or other contractual document. Such specification must be comprehensive, complete, and in compliance with legislation, health and safety provisions.

1.4 Customer Specification / Requisition – Inquiry and Order

The specification of the function and the conditions of use for the valve, which is part of the inquiry and/or the purchase order, is decisive for the type selection, materials, nominal size, application limits with regard to pressure and temperature or resistance and for the selection of accessories for the ball valve. This information must be clear, complete, coherent and in accordance with applicable laws, regulations and standards.

1.5 Automated Ball Valve

The ball valve is either operated manually or its function is automated with an actuation and control system.

Often, ARGUS ball valves are automated with a mounted pneumatic, hydraulic or electric actuator with the corresponding control instrumentation for automated functioning and monitoring of the complete automated ball valve.

The actuator can either be mounted directly on the valve body or the valve may utilize a coupler and/or bracket to securely and safely attach an automated package (actuation and control system).

Automated operation can involve particular hazards especially in view of moving parts, energy loads etc.

The nameplates and the manufacturer documentation / safety advice for all components must be strictly followed.

The operating instructions for the ball valve are usually integrated into the aggregate operating instructions for the complete automated ball valve.

ARGUS

2 Safety Information

2.1 Intended Use

ARGUS ball valves are used as shut-off devices, e.g. in pipework or at attached vessels in the field for transport and processing of liquids, gases and solid-containing fluids.

The valve design takes into account international and national regulations, such as the European Directive for Pressure Equipment 2014/68/EU, EN12516, AD 2000 Regulations, API 6D and ASME/ANSI B16.34 and others depending on the specified application and legislation.



Proper use of the ball valves will never exceed the application limits such as instructed on the valve nameplate, by additional marking on the product, in the product specification, specific provisions, or in this manual.

Failure to comply with this information is considered to be misuse, which can be the cause of personal injury or product damage or malfunctioning, which are not covered by the manufacturer's warranty.

Comprehensive Quality Assurance, certified in accordance with ISO 9001 e.g., has always been a determining factor within the overall process of design, procurement, manufacturing and marketing at all Flowserve sites.

All relevant laws, directives, standards and specifications are adopted for specific applications of the valves.

2.2 Operating Limits of the Ball Valve – Refer to the Nameplate

ARGUS ball valves are generally designed for special applications. Type, model, material selection, nominal size, special features, attachments, accessories and valve qualification are adapted to the specified operating conditions. This results in application limits concerning fluids (media), pressure, temperature and other application and environmental conditions for each ball valve.

The metallic type plate, or "manufacturer nameplate", fixed to the ball valve provides information on these application limits. Also refer to Chapter "Nameplate: Identification of the Ball Valve".

The specified operating limits as shown on the nameplate, must never be exceeded.

2.3 Responsibility of Plant Engineering and Operation

ARGUS ball valves are often installed as safety-relevant components in plants and systems. Risks due to incorrect installation or unintended use and operation must be prevented.

The qualified personnel entrusted with the assembly of the system are responsible for ensuring that the ball valve is permanently integrated safely into the system in accordance with the relevant legal framework, standards, specification and in accordance with these instructions.

The plant operator is responsible for commissioning and continuous operation of the ball valve and must guarantee the correct application of the valve. In particular, the operating limits of the ball valve must be observed.

Any hazards resulting from the operation of the valve, e.g. due to extreme surface temperatures, must be avoided. **Comprehensive protection of people and the environment must be ensured.** Observe all local and national regulations on occupational safety and health.

2.4 Qualified Personnel for Installation and Operation

All personnel involved in the operation, installation and maintenance of the unit must be qualified to carry out the work involved. If the personnel in question does not already possess the necessary knowledge and skill, appropriate training and instruction must be provided. If required, the operator may entrust the manufacturer / supplier to provide applicable training.

Always co-ordinate repair activities with operation and health and safety personnel, and follow all plant safety requirements and applicable safety and health laws and regulations.

2.5 Safety Relevant Symbols

Main Symbols used in these instructions:

Symbol	Signal word	Meaning
	DANGER	Failure to observe this “Danger” may result in loss of life or serious injury.
	WARNING	Failure to observe this “Warning” may result in injury and/or material damage.
	CAUTION	“Caution” is required to prevent damage to property or to avoid operational malfunction.
	NOTICE	A “Notice” refers to technical correlations that may not always be apparent – even to qualified technicians.
		The “Safety Alert Symbol” is used to alert the reader. Safety messages following this symbol must be obeyed to avoid possible injury or death.

Specific Hazard Symbols / Responsibility of the Valve User:

Symbol	Meaning	Description
	Pressure Hazard	Danger! All provisions and legislation in relation to pressurized equipment must be observed.
	Suspended Load!	Danger! Falling loads can cause serious injury or death. Never step under suspended loads!
	Center of Gravity!	Warning! Adequate lifting gear must be used. Lifting equipment is always attached to the valve body and actuator.
	Hot / Deep Cold Surface!	Danger! Extreme surface temperature: adequate personal protection must be applied. Area hazards must be observed.
	Flammable Substances!	Danger! Flammable substances are extremely dangerous to work with and around. The plant operator must avoid any ignition hazard.
	Explosive Substances / Atmosphere!	Danger! In a potentially explosive atmosphere, the ignition risk must be eliminated by adequate equipment and procedures.
	Toxic Substances!	Warning! Warning sign for toxic substances. The plant operator is responsible for protective measures and safety procedures.

It is the ultimate responsibility of the plant operator or installation contractor to clearly communicate all hazards that might arise from operation or installation conditions and to eliminate any such risk for persons and environment.

Personnel must be adequately trained. Personal protective equipment and tools must be suitable.

Instructions and marking must be unambiguous.

ARGUS

2.6 Ball Valve as Pressure Equipment

A valve is pressure bearing equipment usually integrated into a piping system. Any hazard for persons or for the environment which might arise from the pressurized substances ("fluids") being transported within the pipeline system must be eliminated.

In Europe, Directive 2014/68/EU, i.e. the "European Pressure Equipment Directive" (PED), and the corresponding laws and standards govern design, material selection, manufacture and conformity assessment of pressure equipment for the European market. ASME B16.34 e.g. and the associated standards as well as the pertinent publications of the American Petroleum Institute provide widely accepted rules and guidelines for qualified valve design and production.

Material selection, design, calculation, and quality assurance during material procurement, in production and on finished products are the main guarantors to eliminate pressure-related hazards when the ball valves are used as intended.

The ball valve must be designed and qualified in compliance with all statutory legal regulations at the location of installation.

DANGER of Pressure Hazards



The manufacturer nameplate permanently attached to the ball valve body indicates the operating limits of the equipment. The maximum permissible pressure and the maximum permissible temperature must never be exceeded. The substances transported and treated must comply with the specification applied for the valve design. Legislation, directives, and regulations must be followed.



2.7 Use in Potentially Explosive Atmosphere

ARGUS ball valves are generally suitable for operation in potentially explosive atmospheres. When used as intended, the ball valves do not have their own potential sources of ignition and are therefore not "equipment" as defined by Article 1 of Directive 2014/34/EU (European "ATEX Directive") e.g..

DANGER in Hazardous "Ex Area"



In the case of potentially explosive atmospheres, the specific limit values applicable to the hazardous area must be observed. This relates in particular to the permissible fluid temperature or valve surface temperature.



The personnel entrusted with installation and operation in potentially explosive atmospheres must be adequately qualified and must wear a personal protection equipment suitable for explosive atmospheres. All applicable laws, directives and regulations for hazardous areas must be followed.



2.8 Automated Ball Valve – Safety Aspects

When the ball valve is equipped with a pneumatic, electric, or hydraulic actuation systems, particular risks arise from the automated functioning, the operation of the instruments, or at the function test.

The valve must never be operated when uninstalled from the pipeline.

WARNING: Risk of Injury when operating outside pipeline



Automated ball valves may only be operated when installed in a pipeline.

Outside the pipeline, the actuation system shall be stored in an unpressurized and de-energized state.

In case a function test of the uninstalled unit is necessary, the interior of the valve must be capped in a way that no limbs can enter. Safe distance must be kept from moving parts.

The personnel entrusted with installation, connection, and operation of the units must be particularly qualified for the specific automation and instrumentation.

Electric hazards must be avoided. Uncontrolled pneumatic or hydraulic energy may cause severe injuries.

Instrumentation and actuation components must be suitable for the operating environment.

It is essential that the safety instructions concerning each component are followed. As a rule, the manufacturer nameplate on instrumentation and actuator as well as the user instructions must be strictly observed.

3 Delivery / Goods Receipt

3.1 Transportation

Ball valves and/or ball valve assemblies and accessories must be delivered in safe packaging. It is also necessary to comply with the applicable regulations on load securing. The equipment must in particular be protected against tilting and slipping.

ARGUS ball valves are delivered with factory fitted protective caps which prevent the penetration of dirt and foreign particles into the interior. Furthermore, the caps protect the flange sealing surface.

Packaging methods (e.g. "Seaworthy Packing") are chosen in accordance with customer specification or in order to protect the equipment during special transport modes.

Immediately after receipt of the product/system it must be checked against the delivery/shipping documents for its completeness and that there has been no damage in transportation.

Any shortage and/or damage must be reported immediately to Flowserve. Later claims cannot be accepted.

3.2 Goods Acceptance / Verification of the Delivery and Accompanying Documents

A delivery note is enclosed with each delivery. The correctness and completeness of the delivery must be inspected and confirmed to the deliverer.

The appropriate installation and operating instructions as well as required compliance documentation are part of the delivery. Their absence must be advised to the supplier.

3.3 Unpacking / Transport to Storage Area

In the case of larger valves or complete units, it may be necessary to use a hoist with lifting straps for withdrawing the delivered goods from the packing:

- ▶ Loosen and remove load securing material and wedges within the package.
- ▶ Dismantle the crate, where necessary.
- ▶ Position the lifting straps around the ball valve body.

WARNING: Observe Center of Gravity

When using lifting belts on ball valve actuator units, the center of gravity of the unit can be higher than the attachment point. The total unit must be secured against twisting and tilting.

- ▶ Protect accessories (actuator, instrumentation, piping) and attachments from damage.

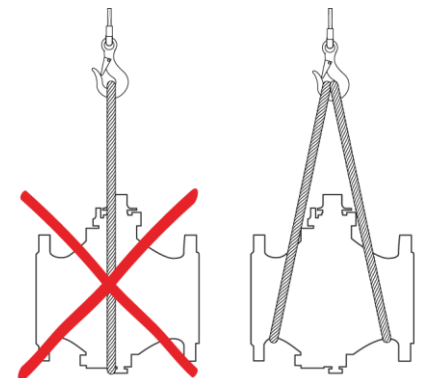

DANGER under suspended loads
Never stand under suspended loads!



3.4 Identification of the Delivery

The details on the ball valve nameplate must correspond with the details on the delivery document (delivery note).

3.5 Storage

Ball valves must be stored in a suitable place, dry and free from dirt or detrimental atmosphere. It is advisable not to remove the protective caps in order to protect the valve interior and the connection sealing surfaces or threads.

As a rule, the ball valve is to be stored in the **open** position as supplied.

3.6 Transport to the Assembly and Utilization Site

The instructions under 3.3 are to be observed.

ARGUS

4 Nameplate: Identification of the Ball Valve

The manufacturer nameplate permanently affixed to the ball valve body provides the most important information regarding the design and use of the ball valve.

If the type plate is missing or illegible, the ball valve must not be put into operation.

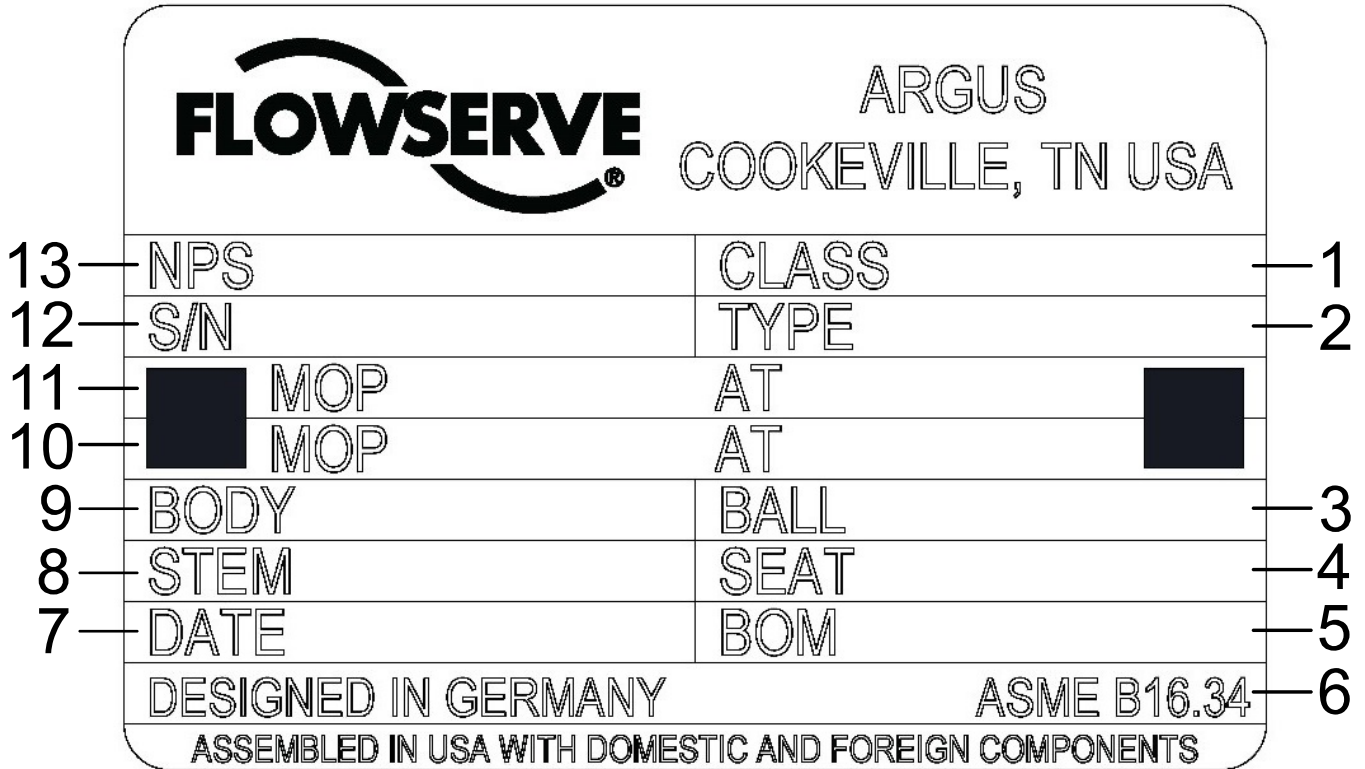

- 1 Nominal Pressure (CLASS)
- 2 ARGUS Type
- 3 Ball Material
- 4 Seat Material
- 5 BOM (Bill of Materials) No. / Reference
- 6 Design Standard
- 7 Date of Manufacture
- 8 Stem Material
- 9 Body Material
- 10 MOP (Maximum Operating Pressure) [bar] at Minimum Temperature [°C]
- 11 MOP (Maximum Operating Pressure) [bar] at Maximum Temperature [°C]
- 12 Serial Number
- 13 Nominal Pipe Size (NPS) [inch]

Additional Marking on the Ball Valve

In addition to the essential information given on the nameplate, the ball valve may come with supplementary stamping, plates, decals, or labels in compliance with statutory regulations, client specification, special application rules or to advise particular application limits.

Pay attention to all marking on the valve.

5 Installation

Ball valve series **FK 75C** and **FK 76C** are usually intended to be connected to pipework with matching flange connection.

The ball valve is designed for use under normal load in the pipework. Particular operating conditions must be clearly specified in the customer requisition/inquiry. In the case of deviations from these conditions, Flowserve must be consulted.

5.1 Preparation for Installation

The following points must be observed before installation:

- ▶ Pipework must be strong enough to safely bear the ball valve and its accessories. Verify if special support is needed for the unit.
- ▶ Pipework must be cleaned before installation.
- ▶ There must be sufficient clearance above and to the side of the valve and/or attachments to permit maintenance, inspection or repair work without any risk.
- ▶ Extensions and attachments that are used for heat removal or heating must not be insulated.
- ▶ If the ball valve is intended for regular manual operation, then a standing area must be provided for the operator on which the latter can safely apply the necessary forces in accordance with applicable user, local and national standards as well as guidelines.



Observe possible flow direction! For unidirectional ball valves (special case), the flow direction is indicated by an arrow on the body.

5.2 Installing Flange Connection

- ▶ Transport the ball valve to the assembly location using suitable lifting devices which are appropriate to the weight and the size of the ball valve (052-01).

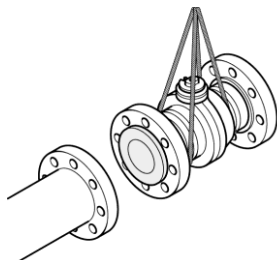

052-01

- ▶ Remove protective caps (052-02).

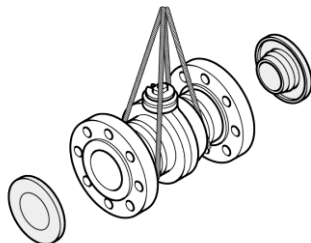

052-02

- ▶ Clean the pipework end, connection flange and sealing surfaces (052-03).

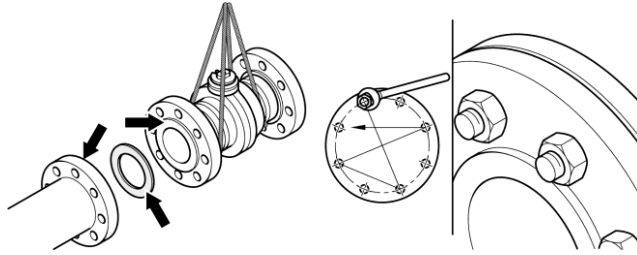
ARGUS

052-03

▶ Assembling the first flange:

- Fix the ball valve to the connection with some bolts and position the seal.
- Ensure the correct position of the ball valve and seal (052-04).

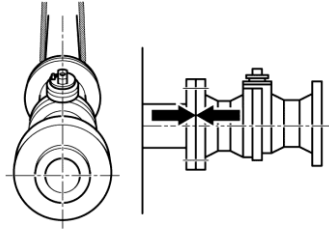

052-04

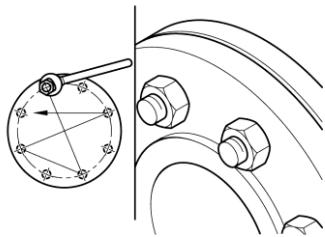
▶ Tighten the bolts crosswise (052-05).

052-05

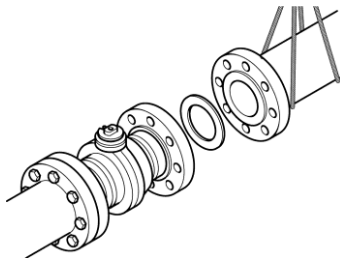
▶ Assembling the second flange: Procedure as for the first flange (052-06).

052-06

▶ Check tightness after completed assembly works.



Safety instructions relating to the pipework system (including fittings) are to be provided by the operator.



Design-relevant pressure and temperature fluctuations must be inquired with the manufacturer.



The flanges used are standard flanges (e. g. standard flanges per ASME B16.5). The tightening torques of the bolts must be determined according to the standard flange connection.



After completion of the assembly – before the ball valve is actuated – a flushing of the pipeline system is recommended.



If pipework forces are transferred to the valve, then the design must be inquired with the manufacturer accordingly.



If the ball valve is intended to serve as permanent shut-off from the atmosphere, a blank flange or equivalent end must be provided by the end user.

5.3 Actuator Mounting / Orientation of the Valve-Actuator Unit

Actuators are usually installed above the ball valve. The shaft connection is in a vertical position. Other installation orientations are possible according to the evaluation of the specific conditions. If in doubt, please consult Flowserve.



In case of heavy and/or asymmetrical actuators or with units which are not installed vertically, bending and/or torsional forces can occur – especially on extended stems with a stuffing box.

Support of the actuator in the installed position may be required.

Additionally, in the case of critical vibrations or impacts during operation, it can be useful to additionally support the actuator or provide shock absorption.

ARGUS

6 Commissioning – Recommended Practice

Before commissioning and putting into service, the valve tightness must be verified.

6.1 Flushing and Pressure Testing the Pipework

Flushing, "hydro testing" and drying are necessary steps before commissioning or placing the unit in service:

- ▶ Thorough flushing cleans pipework, valves and fittings from dirt and foreign particles.



To avoid damage to the seat elements during rinsing, the ball valve must be in the **open** position.

After cleaning, the flange connections must be checked again. If necessary, tighten the bolts again.

- ▶ The ball valve must be operated after flushing.



To prevent damage, the valve must be operated to **fully open** or to **fully closed** position (90°) without intermediate position.

- ▶ The pressure test of the pipework system confirms the tightness and strength of the system section.



DANGER at Pressure Testing

The operating and test limits of the ball valve according to the design standard may never be exceeded!

6.2 Positions of the Ball Valve

The ball valve is open when the flat flanks of the 2 flat stem head or the groove on the square stem head are in parallel to the flow direction.

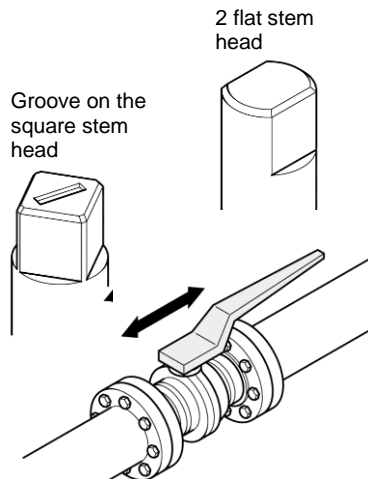



When using a valve wrench, the position of the ball valve must be recognizable by the position of the wrench – for safety reasons:

– **Open position:** Valve wrench parallel to body/pipework

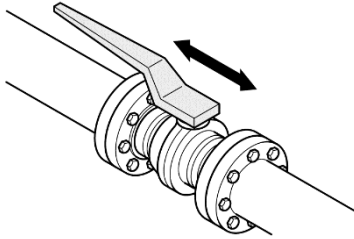

– **Closed position:** Valve wrench crosswise/perpendicular (90°) to the pipework

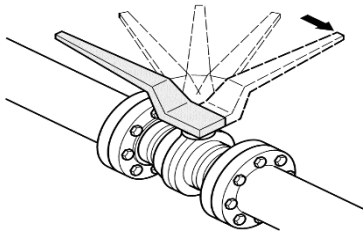

ARGUS FK ball valves must not be used as throttle or control valves.

ARGUS

7 Maintenance

7.1 Periodic Inspection

Regular maintenance and servicing highly depend on the actual operating conditions and the operating frequency of the valve.

It is recommended to periodically inspect the pipework section for leaks and damage. The flange connections must also be inspected.



Flowserve Service Teams and "Quick Response Centers" offer worldwide expert service for inspection, repair, and qualification of ARGUS ball valves on site or under factory conditions.

The recommended inspection can be executed with the valve installed in line. As a rule, the normal plant operation does not have to be interrupted:

- ▶ Inspect the outer seals for leaks and re-tighten if necessary.
- ▶ Inspect the valve for external damage.
- ▶ Clean the valve and repaint if necessary.
- ▶ If possible, open and close the valve and ensure that the valve stem runs smoothly. A jerky running of the shaft can indicate increased torque.
- ▶ Inspect all accessories for tight fit and function.



DANGER at automated operation

Keep hands, hair or clothing away from all moving parts! The operating instructions and safety instructions for the automation components must be followed.

Failure to do so could result in serious injury.

7.2 Exchanging Parts

Under particularly stressful operating conditions, wear of sealing components of the ball valve may occur after a certain period of time. Also very critical or severe service may require that parts of the ball valve are periodically renewed.

Only original spare parts may be used.

Spare Part Information

Flowserve provides spare parts for all ARGUS ball valve types. For inquiry or order, it is important that the ball valve in use is clearly specified.

Technical identification is made either with reference to the item in the order documents of the valve i.e. the order acknowledgment, delivery note or invoice, or the data taken from the nameplate: order number, article number or serial number.



Specification particulars for spare parts inquiry/order and for technical documentation:

Purchase order documents or nameplate

Technical documentation for the exchange

Technical documentation required for disassembly, part exchange and assembly of the valve is available from Flowserve after clear technical identification of the ball valve and is, in principle, attached to spare part deliveries.



ONLY QUALIFIED PERSONNEL and SUITABLE EQUIPMENT

Only appropriately qualified personnel may be entrusted with maintenance and repair work. The tools and equipment used must be suitable and the processes must be safe. Observe all health and safety regulations.

In case of doubt about the qualification of the personnel or about the appropriate equipment, Flowserve must be consulted.



As an attachment to this manual, you will find Disassembly and Assembly Instructions for ARGUS **FK 75C** and **FK 76C**.

Maintenance

 **DANGER**
Ball valve must be depressurized!
Operate the ball valve to allow trapped pressure to escape.
Beware extreme surface temperature!



 **DANGER TO LIFE**
Pay attention to hazardous substances!
Risk of explosion, fire, poisoning or caustic burns!



 **WARNING**
Repair welding or connection welding on pressure equipment is not permitted.

7.3 Returning the Ball Valve: “Valve Information Sheet”

According to the Flowserve Returned Goods Safety Procedure ball valves, which are returned to Flowserve, must be free of dangerous fluid residues. The sender will receive from Flowserve a form, which must be filled-in and signed by the responsible organization and which must clearly attest the fact that the valve does not pose any risk to persons or to the environment when it is delivered and/or during and after disassembly.

Flowserve can only accept a return, if the completed and bindingly signed Flowserve form accompanies the delivery.

ARGUS

8 Decommissioning, De-Installation and Disposal

8.1 Decommissioning and De-Installation

After decommissioning, it is advisable to disconnect the actuation unit and the control components from the valve before dismantling it from the pipework.



DANGER

Ball valve must be depressurized!

Operate the ball valve so that trapped pressure can escape.

Beware extreme temperature!

If hoisting gear is necessary, lifting straps should be used:
Position the lifting straps around the ball valve body.



DANGER when lifting large automated ball valves

For large automated ball valves, the center of gravity must be observed.

Never lift the complete automated ball valves with lifting gear only attached to the actuator!



DANGER TO LIFE

Pay attention to hazardous substances (fluids and gases)!

Risk of explosion, fire, poisoning or caustic burns!



8.2 Disposal

When disposing of the ball valve, the applicable local regulations and laws must be observed.



DANGER

Pay attention to hazardous fluid residues!

Risk of poisoning or caustic burns!

Protect vulnerable environment.

It may be possible to insert the clean decontaminated ball valve components and parts into a recycling program.

FK 75C Disassembly / Assembly



DANGER

Ball valve must be depressurized!

Operate the ball valve so that trapped pressure can escape.

Only adequately qualified and instructed personnel with adequate personal protective equipment and tools may execute this task.

Always pay attention to dangerous fluids and extreme surface temperature.

Use appropriate tools and hoisting gear.

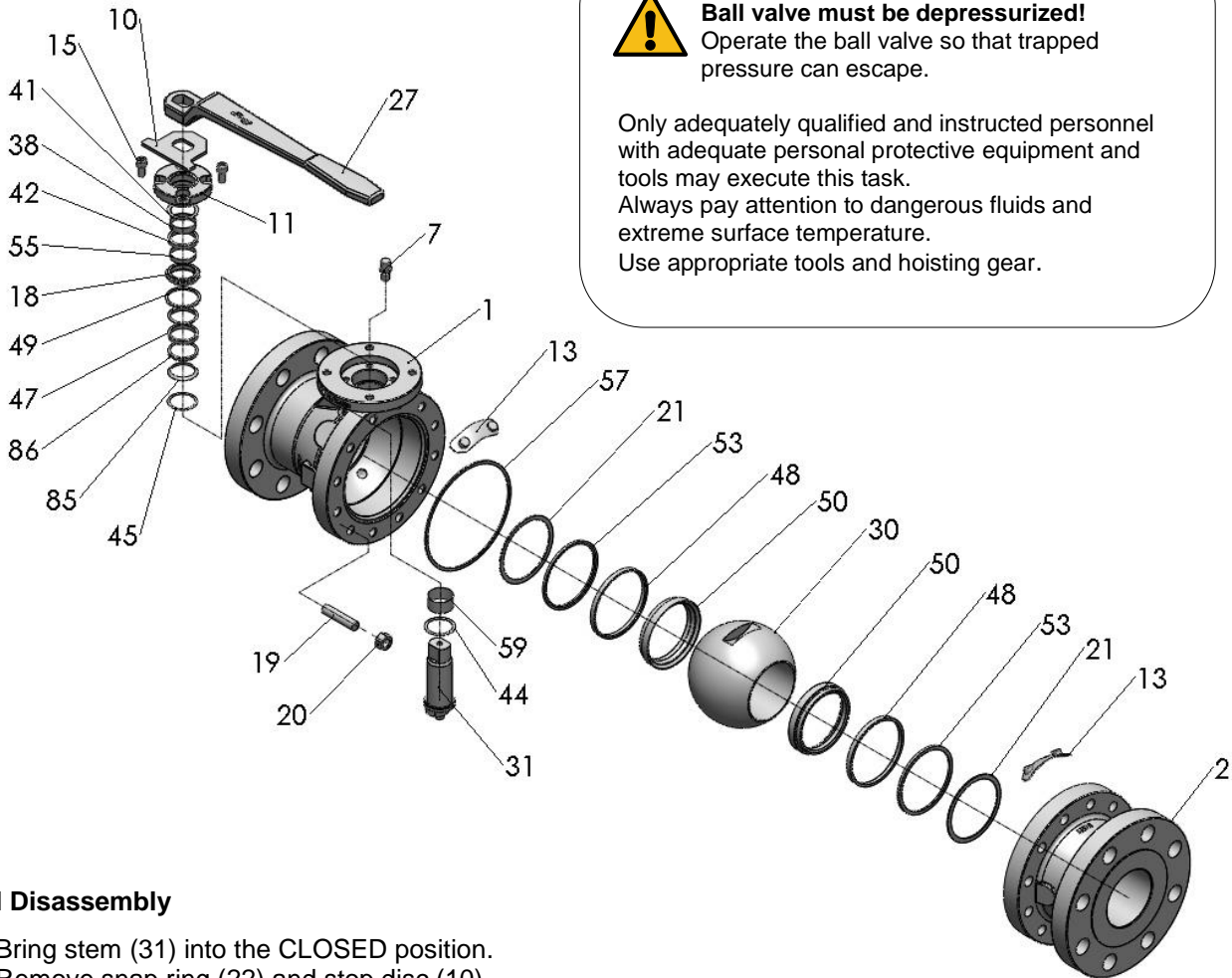

Total Disassembly

- ▶ Bring stem (31) into the CLOSED position.
- ▶ Remove snap ring (22) and stop disc (10).
- ▶ Unscrew cylindrical hexagon Allen head screws (15).
- ▶ Dismantle bonnet (11) with wiper ring (41), bearing tape (38), and sealing ring (42), thrust ring (18) with bearing tape (55) and sealing ring (49).(**)
- ▶ Unscrew hexagon nuts (20) from body (2).
- ▶ Remove body (2), O-ring (51) and sealing ring (57) from body (1).
- ▶ Remove ball (30), ball support pads (13), ball seats (50) with sealing ring (48), thrust ring (53), and Belleville washer (21).
- ▶ Press stem (31) downward and remove from body (1) with bushing (59) and thrust ring (44).
- ▶ Remove ring (47), sleeves (85, 86) and disk (45) upwards.

Replacing Stem Sealing

- ▶ Proceed as for *Total Disassembly* until.(**)
- ▶ Replace seal (47) and sleeves (85, 86).
- ▶ Disk (45) can remain in body (1).

If O-ring sealing is required instead of seal (47), remove sleeves (85, 86).

Disk (45) and thrust ring (18) are then replaced by O-ring sealing (drawings & article number on request).

Additionally, Belleville washer (17) and ring (43) are needed.

Inspect all parts for wear and tear or for any sign of improper functioning.

Partial disassembly may be sufficient.

For reassembly, proceed in reverse order of disassembly.

Replace the worn items by original Flowserve spare parts.

ARGUS

FK 76C Disassembly / Assembly



DANGER

Ball valve must be depressurized!

Operate the ball valve so that trapped pressure can escape.

Only adequately qualified and instructed personnel with adequate personal protective equipment and tools may execute this task.

Always pay attention to dangerous fluids and extreme surface temperature.

Use appropriate tools and hoisting gear.

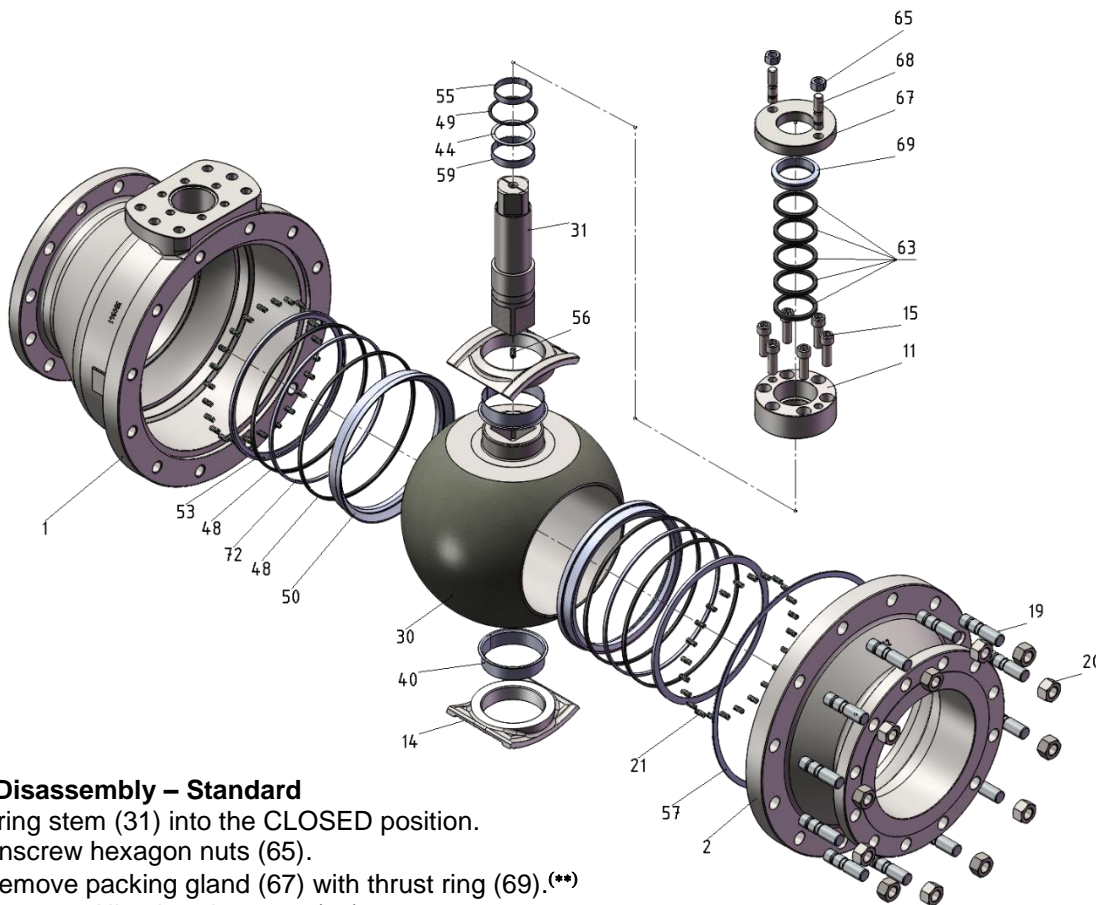

Total Disassembly – Standard

- ▶ Bring stem (31) into the CLOSED position.
- ▶ Unscrew hexagon nuts (65).
- ▶ Remove packing gland (67) with thrust ring (69).(**)
- ▶ Unscrew Allen head screws (15).
- ▶ Remove stuffing box (11) with sealing rings (63), bearing tape (55), and sealing ring (49).
- ▶ Pull out stem (31) with bearing tape (59), thrust ring (44) and compression spring (56).
- ▶ Unscrew hexagon nuts (20) from the body (2).
- ▶ Remove body (2) and seal ring (57) from the body (1).
- ▶ Remove ball (30), counter-bearing (14) with bearing bushing (40), ball seats (50) with sealing rings (48), thrust rings (72) as well as thrust rings (53) and compression springs (21).

Replacing Stem Sealing (Packing)

- ▶ Proceed as for *Total Disassembly* until.(**)
- ▶ Remove and replace sealing rings (63).

Inspect all parts for wear and tear or for any sign of improper functioning.

Partial disassembly may be sufficient.

For reassembly, proceed in reverse order of disassembly.

Replace the worn items by original Flowserve spare parts.

Document No. BA1010_EN Rev.: A – 2019-01-07

Disclaimer

Information in this user manual is believed to be complete and reliable. In spite of all Flowserve's efforts to provide comprehensive information and instructions, sound engineering and safety practices must always be used. Qualified personnel must be consulted. For any further query, Flowserve should be contacted.

ARGUS

Your FLOWSERVE Contact:



Flowserve factory contacts:

Flowserve Corporation
1978 Foreman Drive
Cookeville, TN 38501
Tel: +1 931 432 4021

Flowserve Corporation
3993 W. Sam Houston Parkway North
Suite 100
Houston, TX 77043
Tel: +1 281 469 4166

Flowserve ARGUS Lead Product Operation contact:

Flowserve Flow Control GmbH
Rudolf-Plank-Str.2
76275 Ettlingen
Germany
Tel: +49 7243 103 0

These instructions and detailed product bulletins are also available for download under:

<http://flowserve.com>