

# Installation, Operation, Maintenance Instructions

## Low Temperature Valves

### Series 031 000 Top Entry Vacuum Valves

### Series 035 000 Top Entry Vacuum Valves

| Index |  |
|-------|--|
| 1     | Using Kämmer valves and actuators correctly. |
| 2     | Unpacking                                    |
| 3     | Installation                                 |
| 4     | Quick check                                  |
| 5     | Maintenance                                  |
| 6     | Remove and install actuator                  |
| 7     | Disassemble and assemble valve               |
| 8     | Trouble-shooting chart                       |

## 1 USING KÄMMER VALVES AND ACTUATORS CORRECTLY

### 1.1 General

The following instructions are designed to assist in unpacking, installing and performing maintenance as required on Kämmer products. Product users and maintenance personnel should thoroughly review this bulletin prior to installing, operating or performing any maintenance.



**DANGER:** *In most cases Kämmer valves and actuators are designed for specific applications (e.g. with regard to medium, pressure, temperature). For this reason they should not be used in other applications without first contacting the manufacturer.*

### 1.2 Terms concerning safety

The safety terms **DANGER**, **WARNING**, **CAUTION** and **NOTE** are used in these instructions to highlight particular dangers and/or to provide additional information on aspects that may not be readily apparent.



**DANGER:** *indicates that death, severe personal injury and/or substantial property damage will occur if proper precautions are not taken.*



**WARNING:** *indicates that death, severe personal injury and/or substantial property damage can occur if proper precautions are not taken.*



**CAUTION:** *indicates that minor personal injury and/or property damage can occur if proper precautions are not taken.*



**NOTE:** *indicates and provides additional technical information, which may not be very obvious even to qualified personnel. Compliance with other, not particularly emphasised notes, with regard to transport, assembly, operation and maintenance and with regard to technical documentation (e.g. in the operating instruction, product documentation or on the product itself) is essential, in order to avoid faults, which in themselves might directly or indirectly cause severe personal injury or property damage.*

### 1.3 Protective clothing

Kämmer products are often used in problematic applications (e.g. extremely high pressures, dangerous, toxic or corrosive mediums). In particular valves with bellows seals point to such applications. When performing service, inspection or repair operations always ensure, that the valve and actuator are depressurised and that the valve has been cleaned and is free from harmful substances. In such cases pay particular attention to personal protection (protective clothing, gloves, glasses etc.).

### 1.4 Qualified personnel

Qualified personnel are people who, on account of their training, experience and instruction and their knowledge of relevant standards, specifications, accident prevention regulations and operating conditions, have been authorised by those responsible for the safety of the plant to perform the necessary work and who can recognise and avoid possible dangers.

### 1.5 Installation



**DANGER:** *Before installation check the order-no, serial-no. and/or the tag-no. to ensure that the valve/actuator is correct for the intended application.*

Pipelines must be correctly aligned to ensure that the valve is not fitted under tension.

**1.6 Spare parts**

Use only Kämmer original spare parts. Kämmer cannot accept responsibility for any damages that occur from using spare parts or fastening materials from other manufactures. If Kämmer products (especially sealing materials) have been on store for longer periods check these for corrosion or deterioration before using these products. Fire protection for Kämmer products must be provided by the end user.

**1.7 Service / repair**

To avoid possible injury to personnel or damage to products, safety terms must be strictly adhered to. Modifying this product, substituting nonfactory parts, or using maintenance procedures other than outlined in this instruction could drastically affect performance and be hazardous to personnel and equipment, and may void existing warranties. Between actuator and valve there are moving parts. To avoid injury Flowserve provides pinch-point-protection in the form of cover plates, especially where side-mounted positioners are fitted. If these plates are removed for inspection, service or repair special attention is required. After completing work the cover plates must be refitted.

Apart from the operating instructions and the obligatory accident prevention directives valid in the country of use, all recognised regulations for safety and good engineering practices must be followed.



**WARNING:** Before products are returned to Kämmer for repair or service Kämmer must be provided with a certificate which confirms that the product has been decontaminated and is clean. Kämmer will not accept deliveries if a certificate has not been provided (a form can be obtained from Kämmer).

**1.8 Storage**

In most cases Kämmer Products are manufactured from stainless steel. Products not manufactured from stainless steel are provided with an epoxy resin coating. This means that Kämmer products are well protected from corrosion. Nevertheless Kämmer products must be stored adequately in a clean, dry environment. Plastic caps are fitted to protect the flange faces to prevent the ingress of foreign materials. These caps should not be removed until the valve is actually mounted into the system.

**1.9 Valve and actuator variations**

These instructions cannot claim to cover all details of all possible product variations, nor in particular can they provide information for every possible example of installation, operation or maintenance. This means that the instructions normally include only the directions to be followed by qualified personal where the product is being used for is defined purpose. If there are any uncertainties in this respect particularly in the event of missing product-related information, clarification must be obtained via the appropriate FLOWSERVE sales office.

**2 UNPACKING**

- 2.1 Each delivery includes a packing slip. When unpacking, check all delivered valves and accessories using this packing slip.
- 2.2 Larger valves can be lifted using slings on the yoke rods or, if present, on the lugs provided for this purpose. If slings are used, attach them so that the outer tubing or attaching parts are not damaged.



**WARNING:** If slings are used, be aware that the centre of gravity of the valve may be above the lifting point. In this case, secure or support the valve against rotating, to prevent damage or personnel injury.

- 2.3 Report transport damage to the carrier immediately.
- 2.4 In case of discrepancies, contact your nearest FLOWSERVE sales office.

**3 INSTALLATION**

- 3.1 Clean tubing prior to installing.
- 3.2 If possible, install the valve in an upright position (actuator on top), to ease maintenance. An upright installation position is important with low-temperature applications, in order to keep the distance between the packing material and the medium as large as possible. The packing material then retains the ambient temperature as much as possible.



**NOTE:** Do not insulate extension bonnets that are provided for hot or cold services

- 3.3 Make sure that sufficient overhead clearance above the actuator is maintained, to allow for disassembly of plug from the valve body (see following table).

| Actuator size | Clearance (mm) | Actuator size | Clearance (mm) |
|---------------|----------------|---------------|----------------|
| 37/47         | 95             | P2            | 140            |
| 38/48         | 140            | P3            | 140            |
| 39/49         | 140            | P4            | 140            |
| 39D/49D       | 140            | P5            | 140            |
|               |                | P6            | 200            |
|               |                | P7            | 200            |

- 3.4 If the valve is to be welded into the line, make sure that the valve is shielded from excessive heat.
- 3.5 Connect supply pressure and signal lines. Control valves are supplied with a positioner. The end connections for supply pressure and signal are clearly marked. Actuator and positioner are suitable for max. 4.2 bar (60 psi) supply pressure. If the supply pressure exceeds the pressure specified on the nameplate, a pressure reducing station is required. If instrument air is not available, install an oil separator/air filter in the air inlet line. All connections must be leak free.

**4 QUICK CHECK:**

Before operating, check the valve as follows:

- 4.1 Open and close the valve, and observe the movement of the actuator stem. The movement must be smooth and linear.
- 4.2 Check for maximum stroke through change of signal (for pneumatic positioners, 0.2 - 1.0 bar or corresponding split-range values; for IP positioners, 4-20 or 0-20 mA).
- 4.3 Check all air connections for leaks.
- 4.4 Tighten packing nut (see table 1).

| Thread    | Torque |         |
|-----------|--------|---------|
|           | PTFE   | Grafoil |
| M20 x 1,5 | 3.5    | 6.0     |
| M30 x 1,5 | 7.0    | 17.5    |
| M38 x 1,5 | 11.5   | 20.5    |
| M45 x 1,5 | 27.0   | 48.0    |

**Table 1**

**NOTE:** An excessively tightened gland nut can cause excessive packing wear and can hinder the free movement of the plug stem. The values mentioned in table 1 are suitable for standard packing assemblies. For further details contact FLOWSERVE.

- 4.5 Check fail-safe position. To do this, close supply pressure and observe whether the valve opens or closes as defined.
- 4.6 After use at fluctuating temperatures, re-tighten all bolt connections and check for leaks.

**5 MAINTENANCE**

Check valves for correct functioning at regular intervals (at least once every 6 months) as follows. This check can be made when installed and in many cases without interrupting production. If internal defects are suspected, see section „Disassembly and Assembly of Valve“.

- 5.1 Examine gaskets for leaks and if necessary re-tighten bolts (see Fig. 1).
- 5.2 Check bellows gasket and test connection - if present - for external leaks.
- 5.3 Check valve for damage caused by corrosive residues or corrosive vapours.

- 5.4 Clean valves and repaint as necessary.



**Warning:** To prevent a buildup of electrostatic charge clean the actuator/valve with a damp cloth only.

- 5.5 Check gland nut for correct torque (see table 1).



**NOTE:** An excessively tightened gland nut may cause excessive packing wear and can hinder the free movement of the plug stem.

- 5.6 If possible, open and close valve and check for maximum stroke and smooth movement of the plug stem. Irregular movement of the plug stem may indicate internal defects.



**NOTE:** With graphite packing, irregular movement of the plug stem is normal.



**WARNING:** Keep hands, hair, clothing, etc. away from all moving parts. Failure to do so can lead to serious injury.

- 5.7 Check all accessories for firm seating.
- 5.8 If possible, close supply pressure and check the fail-safe position.
- 5.10 Check stem boot for wear.
- 5.11 Check actuator for leaks. To do this, spray housing, air connections and plug stem guide with leak spray and check for any bubble formation.
- 5.12 Clean plug stem.
- 5.13 Check air filter, if present, and if necessary replace insert.



**NOTE:** For further information regarding service and maintenance please contact your nearest FLOWSERVE office.



**DANGER:** On actuators with aluminium cases the actuator springs must be renewed with original spare parts every 10 years or after 50.000 operating hours which ever occurs first.

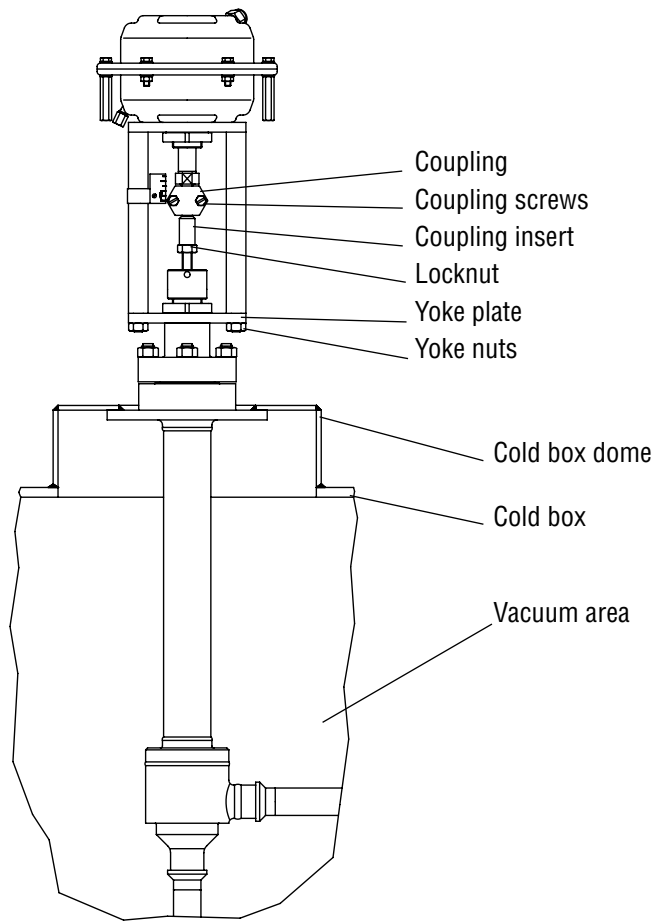

**Typical „Cold-Box“ arrangement  
Valve with series 2 actuator**

**Fig. 1**

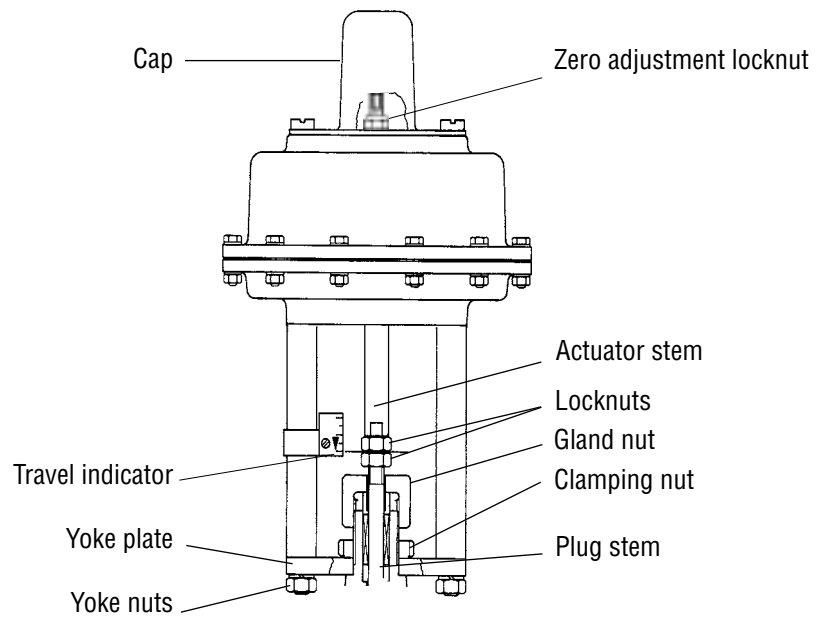

**Series 4 actuator  
Fig. 1a**

**6 REMOVE AND INSTALL ACTUATOR**

**General Information**

We recommend separating the actuator from the valve during all repair work. However, many maintenance and adjusting operations can be carried out in an installed condition.

**6.1 Remove series 4 actuator**

(see Fig 1 + 2)

To remove series 2 actuator see 6.3

**6.1.1 Shut off air supply.**



**DANGER:** *Depressurise the line to atmospheric pressure and drain all fluids from the valve before working on the actuator. Failure to do so can cause serious injury.*

**6.1.2 As required remove any outside tubing.**

**6.1.3 Remove cap and nameplate. Tighten zero adjusting nut until it just touches the surface of the spring housing. This relieves the plug from actuator spring pressure. If the actuator is fitted with a handwheel this can be used to relieve the plug from actuator spring pressure.**

**6.1.4 Using a wrench, secure the actuator stem against turning and using a second wrench loosen the stem locknuts. If the actuator is fitted with a coupling refer to the procedure described in the maintenance instructions for the I/P actuator.**



**NOTE:** *the actuator stem must not be rotated, as this will cause damage to the diaphragm.*

**6.1.5 Loosen gland and clamp nuts.**

**6.1.6 Secure plug stem against turning and unscrew actuator from plug stem by rotating counter-clockwise.**



**NOTE:** *Ensure that the plug assembly is not rotated with the plug seated. This may cause irreparable damage to the seating faces.*

**6.1.7 Remove actuator and remove at the same time locknut, travel indicator disc, gland nut and clamp nut.**

**6.2 Install series 4 actuator**

**Information:**

- Before the actuator is installed, it must be calibrated according to section 8 of the instructions „Pneumatic and Electro-pneumatic Actuators“.
- All worn or damaged parts must be replaced. Reusable parts must be clean.

**6.2.1 Position actuator with clamp nut, gland nut, locknuts and travel indicator disc on the valve.**

**6.2.2.1 Only for „spring-to-close“ actuators:**

Screw actuator onto plug stem by rotating clockwise, until the yoke plate just touches the valve housing and the actuator is aligned forward. If the actuator is fitted with a coupling refer to the procedure described in the maintenance instructions for the I/P actuator.



**NOTE:** *Ensure that the plug assembly is not rotated with the plug seated. This may cause irreparable damage to the seating faces.*

**6.2.2.2 Only for „spring-to-open“ actuators:**

Lift plug stem and screw it into the lower coupling half until the distance between „plug in seat“ and „plug raised“ approximately corresponds to the specified stroke.

**6.2.3 Tighten clamp nut and gland nut.**

**6.2.4 Adjust seat tightness by screwing/unscrewing the plug stem in/out of the actuator stem.**



**NOTE:** *Ensure that the plug assembly is not rotated with the plug seated. This may cause irreparable damage to the seating faces. Open valve, make adjustment, close valve and check for leaks. If the valve is fitted with a bellows seal the plug stem may NOT be rotated at all. In the case of a bellows seal adjustments are made with the coupling.*

**6.2.5 After adjusting, secure the locknuts and the travel indicator disc lying between them against actuator stem and align the travel indicator on the yoke rod.**

**6.3 Remove series 2 actuator**

(see Fig. 1a)

For series 4 actuator see 6.1

**6.3.1 Shut off air supply.**



**DANGER:** *Depressurise the line to atmospheric pressure and drain all fluids from the valve before working on the actuator. Failure to do so can cause serious injury.*

**6.3.2 Disconnect all tubing.**

**6.3.3 Remove 2 coupling screws and remove coupling.**

**6.3.4 Remove yoke rod retaining nuts and lift actuator assembly from the valve.**

**6.3.5 Remove coupling insert and it's locknut from plug stem.**



**NOTE:** *Ensure that the plug assembly is not rotated with the plug seated. This may cause irreparable damage to the seating faces.*

**6.4 Install series 2 actuator**

(see Fig. 1a)

The actuator stem must be fully extended:

Actuators with air-to-open action must be fully vented. Actuators with air-to-close action apply supply pressure. Manually depress the plug stem to ensure the plug is fully seated.

**6.4.1 Screw coupling insert locknut and coupling insert as far as possible onto plug stem.**

**6.4.2 Place the actuator assembly on the valve engaging the yoke rod threads in the lower yoke plate and ensuring the actuator faces in the correct direction.**

**6.4.3 Unscrew the coupling insert until the yoke rods are raised from the lower yoke plate by around 2 mm.**



**NOTE:** *Ensure that the plug assembly is not rotated with the plug seated. This may cause irreparable damage to the seating faces.*

**6.4.4 Refit the coupling, ensuring that the arrows embossed on the coupling halves, point upward towards the actuator and secure with 2 retaining screws.**

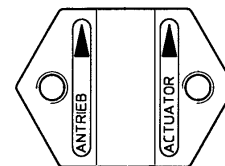

**6.4.5 Apply supply pressure resp. vent actuator to half stroke and refit and tighten yoke rod retaining nuts (15).**

**6.4.6 Connect all tubing.**

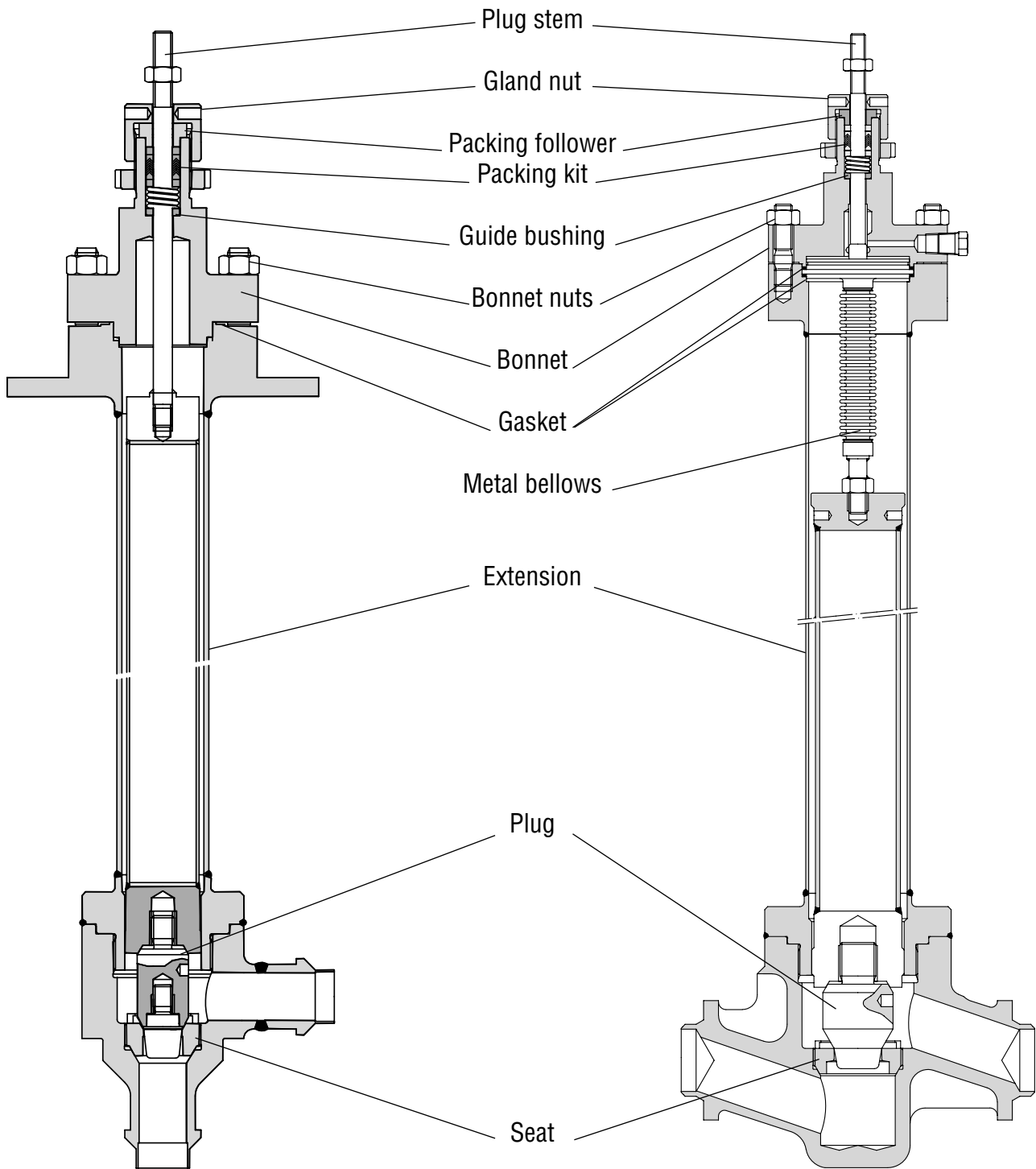

**Fig. 2**

**Fig. 2a**



## 7 DISASSEMBLE AND ASSEMBLE VALVE

### 7.1 Disassemble Valve

(see fig. 2 + 2a)



**WARNING:** As poisonous or hazardous materials may be present, the system must be depressurized and all processing materials must be drained. If necessary, decontaminate the valve. Valves that have been used in cryogenic applications must be allowed to warm-up to ambient temperature. Keep hands, hair, clothing, etc. away from all moving parts. Wear face, eye and hand protection. Failure to do so can lead to serious injury.

- 7.1.1 Remove nuts from bonnet and remove the bonnet.
- 7.1.2 Carefully remove the plug from the extension.
- 7.1.3 Remove gland nut and packing follower from the bonnet and press out the guide and packing from below using a drift (the drift must have a slightly larger diameter than the plug stem).
- 7.1.4 With soft seat version, loosen plug tip with appropriate tool and remove soft seat gasket.



**WARNING:** When the tip of the plug is loosened, medium residue may be released, which has diffused through the gasket.

- 7.1.5 Unscrew seat ring with a special seat ring tool.
- 7.1.6 Check sealing faces of seat ring and plug for damage. Gasket surfaces must be clean and free of damage.



**NOTE:** To prevent damage to the seat, plug or plug stem, follow the above instructions precisely.

- 7.1.9 If a seating surface needs re-machining, seat and plug seating surfaces must be reworked. The seat angle on the plug is 30°, on the seat ring 25°. If the valve is correctly assembled, lapping is not required.



**NOTE:** When re-machining the plug, protect plug stem and bellows from damage and support upper part of bellows towards plug stem. The seat surface must be concentric to the plug stem. When re-machining the seat, the seat surface must be concentric to the seat outer diameter.

### 7.2 Assemble Valve

(see Fig. 2 + 2a)



**DANGER:** All valves are to be reassembled oil and grease free. This is all the more important for oxygen applications because of the danger of an explosion

- 7.2.1 All worn or damaged parts must be replaced. Reusable parts must be clean. Expendable parts such as gaskets, packing and O-rings should always be replaced.

- 7.2.2 Insert seat ring and tighten. For torques, see following table.

| Size     | Thread  | Material | Torque |
|----------|---------|----------|--------|
| DN 25    | M40x1,5 | 1.4571   | 130 Nm |
| DN 40/50 | M60x2   | 1.4571   | 220 Nm |
| DN 80    | M80x2   | 1.4571   | 240 Nm |
| DN 100   | M100x2  | 1.4571   | 450 Nm |
| DN 150   | M148x2  | 1.4571   | 540 Nm |
| DN 200   | M182x2  | 1.4571   | 650 Nm |

- 7.2.3 With soft seat version screw on plug tip using new soft seat.
- 7.2.4 Position plug slowly and upright into the extension.
- 7.2.5 Insert new bonnet gasket.
- 7.2.6 Position bonnet (test connection forwards) and uniformly tighten nuts hand-tight, alternating crosswise
- 7.2.7 Using a torque wrench, gradually tighten all nuts to the prescribed torques (see following table), alternating crosswise.

| Thread | Studs<br>DIN 939 |
|--------|------------------|
| M 8    | 20 Nm            |
| M 10   | 35 Nm            |
| M 12   | 60 Nm            |
| M 16   | 145 Nm           |
| M 20   | 280 Nm           |

- 7.2.8 Replace packing by inserting packing rings one at a time tapping each one down with a suitable bushing.



**NOTE:** ensure that the gaps in the packing rings are distributed evenly around the circumference in the packing box (gaps **not** in line). Different packings and fitting sequences are shown in the spare parts list.

- 7.2.9 Insert packing follower. Fit gland nut for transport purposes only. Gland nut to be fitted correctly and tightened down when actuator is mounted (see table 1).
- 7.2.10 Refit and adjust the actuator as described in section 6.

| Fault               | Possible Cause  | Remedy  |
|---------------------|---|---|
| Stem motion impeded | 1. Packing excessively tightened<br>2. Supply pressure inadequate<br><br>3. Positioner defective  | 1. Tighten gland nut slightly more than „finger-tight“<br>2. Check system for leaks in the supply pressure or signal lines. Re-tighten the connections, if necessary replace leaky lines<br>3. See operating instructions for positioner  |
| Excessive leakage   | 1. Bonnet loose<br>2. Worn or damaged seat ring/plug<br>3. Gaskets damaged<br>4. Inadequate actuator thrust<br>5. Plug incorrectly adjusted<br>6. Incorrect direction of flow<br>7. Handwheel incorrectly adjusted (acts like end stop) | 1. See step 7.2.7 for correct tightening of bonnet.<br>2. Re-machine or replace seat ring/plug.<br><br>3. Replace gaskets<br>4. Check air feed. If air feed is OK, contact dealer.<br>5. Correctly adjust plug<br>6. Check specification. Contact dealer<br>7. Adjust handwheel |
| Inadequate flow     | 1. Plug incorrectly adjusted (short stroke)<br>2. Positioner defective<br>3. Operating requirements too high<br>4. Handwheel incorrectly adjusted (acts like end stop)  | 1. Correctly adjust plug<br><br>2. See operating instructions for positioner<br>3. Check operating data. Contact dealer<br><br>4. Adjust handwheel  |
| Plug slams          | 1. Plug adjustment incorrect<br>2. Inadequate supply pressure<br>3. Trim too large for flow rate  | 1. Correctly adjust plug<br>2. Check supply pressure, seal leaks, remove blockage<br>3. Replace trim  |

**Regional Headquarters**
**Flowserve EMA**

Burrell Road, Hayward Heath  
 West Sussex, RH16 1TL  
 England  
 Telephone: +44 (0) 1444 314400  
 Facsimile: +44 (0) 144 3144401

**Flowserve America**

1350 N. Mt. Springs Prkwy.  
 Springville, UT 84663  
 USA  
 Telephone: +1 801 489 8611  
 Facsimile: +1 801 489 3719

**Flowserve Asia**

12 Tuas Avenue 20  
 638824  
 Republic of Singapore  
 Telephone: +65 862 3332  
 Facsimile: +65 862 4940

**Main Sales Offices EMA (Europe, Middle East, Africa)**
**Flowserve France**

7 Avenue de la Libération  
 63300 Thiers Cedex  
 France  
 Telephone: +33 (0) 4 73 80 42 66  
 Facsimile: +33 (0) 4 73 80 14 24

**Flowserve Switzerland**

Allee du Quartz 1  
 CH-2300 La-Chaux-de Fonds  
 Switzerland  
 Telephone: +41 (0) 32 925 9700  
 Facsimile: +41 (0) 32 926 5422

**Flowserve Germany**

Manderscheidstr. 19  
 45141 Essen  
 Germany  
 Telephone: +49 (0) 201 8919 5  
 Facsimile: +49 (0) 201 8919 662

**Flowserve Eastern Europe**

12, av. du Québec  
 91965, Courtaboeuf Cedex  
 France  
 Telephone: +33 (0) 1 60 923 251  
 Facsimile: +33 (0) 1 60 923 299

**Flowserve South Africa**

Unit 1  
 12 Director Road  
 Spartan Ext 2, Kempton park  
 Gauteng  
 South Africa  
 Telephone: +27 11 923 7300  
 Facsimile: +27 11 974 6420

**Flowserve Middle-East**

C/O Saleh & Abdulaziz Abahsain  
 P.O. Box 209  
  
 Al Khobar 31952  
 Saudi Arabia  
 Telephone: 9663 857 3442  
 Facsimile: 9663 859 5284

**Flowserve Austria**

Kasernengasse 6  
  
  
 9500 Villach  
 Austria  
 Telephone: +43 (0) 424241 181-0  
 Facsimile: +43 (0) 424241 181 50/51

**Flowserve Benelux**

Van Leeuwenhoekweg 6  
  
  
 3225 LX Hellevoetsluis  
 The Netherlands  
 Telephone: +31 (0) 181 330044  
 Facsimile: +31 (0) 181 330040

**Flowserve Italy**

Via Prealpi, 30  
 Cormano (Milano)  
 Italy  
 Telephone: +39 (0) 2663251  
 Facsimile: +39 (0) 26151863

**Flowserve Spain**

Luis Cabrera, 86-88  
 E-28002 Madrid  
 Spain  
 Telephone: +34 9 15 152 032  
 Facsimile: +34 9 14 136 747

**Flowserve Portugal**

Av. Dr. Antunes Guimaraes, 1159  
 Porto 4100-082  
 Portugal  
 Telephone: +351 22 619 8770  
 Facsimile: +351 22 619 7575

**Flowserve Scandinavia**

Gelbgjutaregatan  
 58933 Linköping, Östergötland  
 Sweden  
 Telephone: +46 13 316100  
 Facsimile: +46 13 136054