



USER INSTRUCTIONS

Logix[®] 3200MD+

Digital Positioners

FCD LGENIM0110-0 05/16

**Installation
Operation
Maintenance
Manual**



Experience In Motion

Logix 3200MD+ Positioner

The Flowserve Logix 3200MD+ Digital HART® positioner utilizes state-of-the-art piezo technology to provide superior performance and reliability. The Logix 3200MD+ can be easily configured using the local buttons, HART handheld, and ValveSight software.

The following instructions are designed to assist in unpacking, installing and performing maintenance as required on Logix® 3200MD+ positioners. Series 3200 is the term used for all the positioners herein; however, specific numbers indicate features specific to model (i.e., Logix® 3200 indicates that the positioner has HART® protocol). See the Logix® 3200MD+ Model Number table in this manual for a breakdown of specific model numbers.

User Instructions cannot deal with all possible situations and installation options. It is required that only trained and qualified technicians are authorized to adjust, repair or work on control valves, actuators, positioners and other accessories. Review this bulletin prior to installing, operating or performing any maintenance on the valve. Additional Installation, Operation, and Maintenance Instructions (IOMs) cover other features (such as valves, special trim, actuators, handwheels, and packing).

To avoid possible injury to personnel or damage to valve parts, DANGER, WARNING and NOTE indicators must be strictly followed. Modifying this product, substituting non-factory parts or using maintenance procedure other than outlined could drastically affect performance and be hazardous to personnel and equipment and may void existing warranties. This manual should be used in conjunction with applicable local and national laws. Failure to comply with User Instructions will render the manufacturer's guarantee and liability null and void. Unless otherwise agreed, the manufacturer's general terms and conditions of sale shall apply.

CONTENTS

Quick Start Instructions

Page 277

1	SCOPE OF MANUAL	5	19.1	DETERMINE AIR ACTION	20
2	INTENDED USE	5	19.2	CONNECT SUPPLY PORT	21
3	PRODUCT IDENTIFICATION	5	19.3	VENTED DESIGN	21
4	LOGIX 3200+ MODIFICATION	6	20	ELECTRICAL CONNECTIONS	23
5	SAFETY	6	20.1	ELECTRICAL TERMINALS.....	23
6	PACKAGING & TRANSPORT	6	20.2	COMMAND INPUT (4-20 MA) CONNECTION	23
7	STORAGE	6	20.3	MULTI-FUNCTION CARD (AO, DO, DI).....	25
8	UNPACKING	6	20.4	REMOTE MOUNT	26
9	PRE-INSTALLATION INSPECTION	6	20.5	CONNECTIONS FOR INTRINSICALLY SAFE OPERATION.....	27
10	PROTECTIVE CLOTHING	6	21	STARTUP	27
11	QUALIFIED PERSONNEL	7	21.1	QUICK START INSTRUCTIONS	27
12	VALVE & ACTUATOR VARIATIONS	7	21.2	LOCAL USER INTERFACE OVERVIEW.....	27
13	SPARE PARTS.....	7	21.3	CONFIGURATION SWITCH SETTINGS.....	28
14	SERVICE / REPAIR.....	7	21.4	STROKE CALIBRATION.....	29
15	PRINCIPLES OF OPERATION	8	21.5	ANALOG OUTPUT (AO) CALIBRATION.....	30
15.1	BASIC OPERATION.....	8	22	POSITIONER FUNCTIONS.....	30
15.2	HART.....	8	22.1	LIVE MANUAL TUNING (ADJUSTING THE GAIN).....	30
15.3	POSITION DEFINITION.....	8	22.2	LOCAL CONTROL OF VALVE POSITION.....	30
15.4	COMMAND INPUT AND FINAL COMMAND.....	8	22.3	COMMAND SOURCE RESET	30
15.5	OUTER LOOP	9	22.4	FACTORY RESET.....	30
15.6	INNER LOOP.....	9	22.5	VIEWING VERSION NUMBERS	31
15.7	DETAILED SEQUENCE OF POSITIONER OPERATIONS	9	22.6	ANALOG INPUT CALIBRATION.....	31
15.8	INNER LOOP OFFSET	9	22.7	SELECT AND CALIBRATE ANALOG OUTPUT	31
16	SPECIFICATIONS.....	11	22.8	SELECT DISCRETE OUTPUT	31
16.1	INPUT SIGNAL	11	23	HART COMMUNICATION.....	32
16.2	PNEUMATIC OUTPUT.....	11	23.1	VALVESIGHT® DTM	32
16.3	AIR SUPPLY	11	23.2	HART 375/475 HANDHELD COMMUNICATOR.....	32
16.4	ANALOG OUTPUT – MULTI-FUNCTION CARD	11	23.3	CHANGING HART VERSIONS	32
16.5	STROKE OUTPUT.....	12	23.4	BURST MODE	33
16.6	REMOTE MOUNT SPECIFICATIONS	12	24	MODEL FEATURES.....	34
16.7	POSITIONER PERFORMANCE CHARACTERISTICS	12	24.1	MD+ POSITIONER DIAGNOSTIC LEVELS	34
16.8	PHYSICAL SPECIFICATIONS	12	24.2	VALVESIGHT® DTM DIAGNOSTIC LEVELS.....	34
16.9	TEMPERATURE	12	25	MULTI-FUNCTION CARD.....	35
16.10	VALVESIGHT® DTM SOFTWARE SPECIFICATIONS.....	12	25.1	ANALOG OUTPUT (AO)	35
17	HAZARDOUS AREA CERTIFICATIONS.....	13	25.2	DISCRETE OUTPUT (DO)	35
18	MOUNTING AND INSTALLING	15	25.3	DISCRETE INPUT (DI)	35
18.1	MOUNTING TO MARK ONE LINEAR VALVES	15	26	REMOTE MOUNT	36
18.2	MOUNTING TO STANDARD VALTEK ROTARY VALVES	16	26.1	REMOTE MOUNT OPERATION	36
18.3	OPTIONAL VALTEK ROTARY MOUNTING PROCEDURE.....	18	27	POSITIONER MAINTENANCE	37
18.4	MOUNTING TO ROTARY NAMUR (AUTO MAX) VALVES	19	27.1	SCHEDULED MAINTENANCE	37
19	TUBING	20	27.2	REQUIRED TOOLS AND EQUIPMENT	37
			27.3	TORQUE REQUIREMENTS FOR SCREWS.....	37
			27.4	REPLACING THE MULTI-FUNCTION CARD.....	37
			27.5	REPLACING A MAIN BOARD	38
			27.6	REPLACING THE PRESSURE SENSOR BOARD.....	38
			27.7	REPLACING AND CLEANING A SPOOL VALVE	39
			27.8	REPLACING A DRIVER MODULE ASSEMBLY	40
			28	TROUBLESHOOTING	42
			28.1	TROUBLESHOOTING GUIDE	42
			28.2	STATUS CODE INDEX.....	43
			28.3	STATUS CODE DESCRIPTIONS	44
			28.4	HELP FROM FLOWSERVE.....	52
			29	DISPOSAL.....	52
			30	POSITIONER DIMENSIONS.....	53

30.1	POSITIONER DIMENSIONS	53	31.2	SPARE PARTS KITS.....	56
31	HOW TO ORDER	54	31.3	MOUNTING KITS.....	57
31.1	POSITIONERS	54			

FIGURE 1:	CERTIFICATION LABELS.....	5
FIGURE 2:	MODEL CODE LABEL	5
FIGURE 3:	PRINCIPLES OF OPERATION OF LOGIX 3200MD+ .	8
FIGURE 4:	LOGIX 3200MD+ DIGITAL POSITIONER SCHEMATIC (DOUBLE ACTING RELAY - AIR TO OPEN	10
FIGURE 5:	MOUNTING TO MARK ONE LINEAR VALVES.....	15
FIGURE 6:	VALTEK ROTARY TAKE-OFF ARM	16
FIGURE 7:	VALTEK ROTARY FOLLOWER ARM	16
FIGURE 8:	VALTEK ROTARY MOUNTING.....	17
FIGURE 9:	VALTEK ROTARY FINAL ORIENTATION	17
FIGURE 10:	OPTIONAL ROTARY MOUNTING	18
FIGURE 11:	AUTOMAX BRACKET	19
FIGURE 12:	AUTOMAX ASSEMBLY.....	19
FIGURE 13:	LINEAR, DOUBLE ACTING, AIR TO OPEN.....	20
FIGURE 14:	ROTARY, DOUBLE ACTING, AIR TO OPEN	20
FIGURE 15:	LINEAR, SINGLE ACTING, AIR TO OPEN	20
FIGURE 16:	EXHAUST VENTS	21
FIGURE 17:	PNEUMATIC CONNECTIONS	22
FIGURE 18:	TERMINAL DIAGRAM.....	23
FIGURE 19:	COMPLIANCE VOLTAGE.....	24
FIGURE 20:	CONDUIT AND GROUNDING	25
FIGURE 21:	MFC ANALOG OUTPUT CIRCUIT	25
FIGURE 22:	MFC DISCRETE OUTPUT CIRCUIT.....	26
FIGURE 23:	MFC DISCRETE INPUT CIRCUIT	26
FIGURE 24:	REMOTE MOUNT BOARD	26
FIGURE 25:	LOCAL USER INTERFACE	27
FIGURE 26:	CHARACTERIZATION CURVES	28
FIGURE 27:	SELECTABLE GAIN SWITCH	29
FIGURE 28:	VALVESIGHT DTM DASHBOARD	32
FIGURE 29:	HART DIP SWITCH.....	32
FIGURE 30:	MULTI-FUNCTION CARD.....	35
FIGURE 31:	REMOTE MOUNT TERMINALS	36
FIGURE 32:	TOOLS FOR POSITIONER MAINTENANCE	37
FIGURE 33:	CABLE PLACEMENT.....	37
FIGURE 34:	MAIN BOARD CONNECTORS	38
FIGURE 35:	INNER COVER	38
FIGURE 36:	MAIN BOARD SCREW	38
FIGURE 37:	PRESSURE SENSOR BOARD.....	39
FIGURE 38:	SPOOL VALVE COVER ASSEMBLY.....	39
FIGURE 39:	SPOOL AND BLOCK	39
FIGURE 40:	DRIVER MODULE BARBED FITTING.....	40
FIGURE 41:	DRIVER MODULE BARBED FITTING.....	41
FIGURE 42:	EXPLODED VIEW	55

1 SCOPE OF MANUAL

The following user information covers the Logix 3200MD+ digital positioner:

- Powder Painted Aluminum Housing
- M20 or 1/2" Conduit Threads
- Comes with or without Multifunctional (MFC) card
- Comes with or without Remote Mount Feedback

2 INTENDED USE

CAUTION: Digital Positioners are pressurized devices designed and rated for specific application conditions. Before installation, check the hazardous certification label and model code labels to ensure that the positioner being installed is correct for the intended application. Do not use the positioner outside its rated design limits. Exceeding the design limits may cause hazardous conditions including equipment or environmental damage or serious personal injury or death.

The specific product design data can be found on the positioner's certification and model code labels, data sheet and calculation sheet (in acc. to the IEC 60534-7:2010)

The Logix 3200MD+ can be used with the following supply gasses: Air, sweet natural gas, nitrogen and CO2. Sour natural gas is not acceptable. For Type nA and Type tb installation only air or inert gas may be connected to the air supply inlet. The air supply must be free from moisture, oil and dust by conforming to the ISA 7.0.01 standard. (A dew point at least 18 degrees Fahrenheit below ambient temperature, particle size below five microns—one micron recommended—and oil content not to exceed one part per million).

The Logix 3200MD+ is designed for use in MODERATE and WORLD-WIDE environmental conditions, ambient temperature range -52 to 85°C (-61.6 to 185°F) and supply pressure of up to 10.3 Bar (150 PSI).

The product offering may include optional ancillary equipment, such as air-filter regulators, solenoid valves, or boosters. Refer to the relevant manufacturer's user instructions for information regarding other ancillary equipment.

3 PRODUCT IDENTIFICATION

Verify that the labels match the intended application.

NOTE: Mark checkbox next to hazardous area information for protection method Logix® 3200MD+ is installed to.

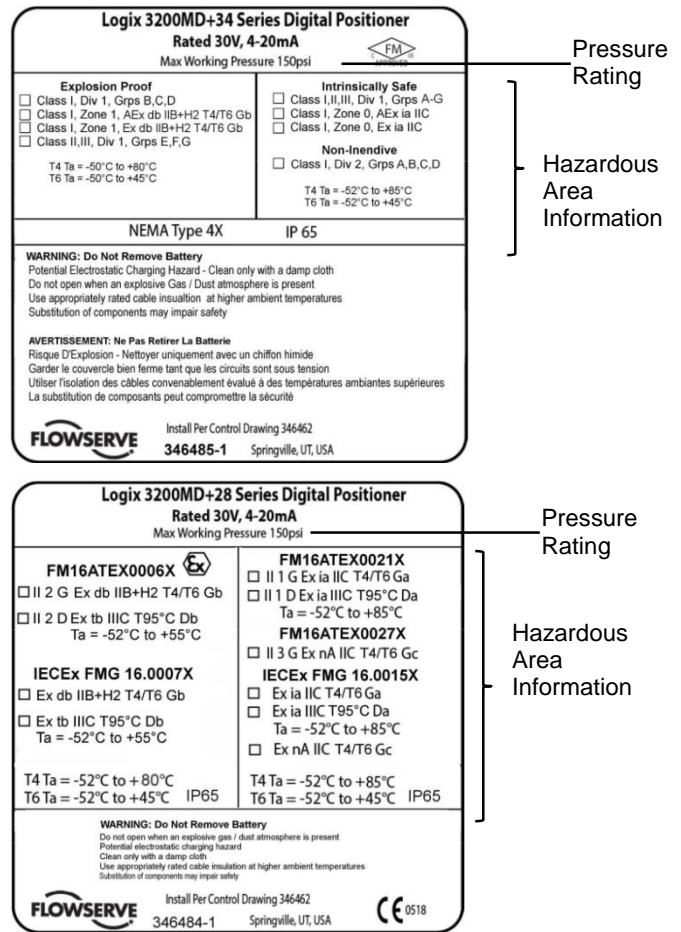

Figure 1: Certification Labels

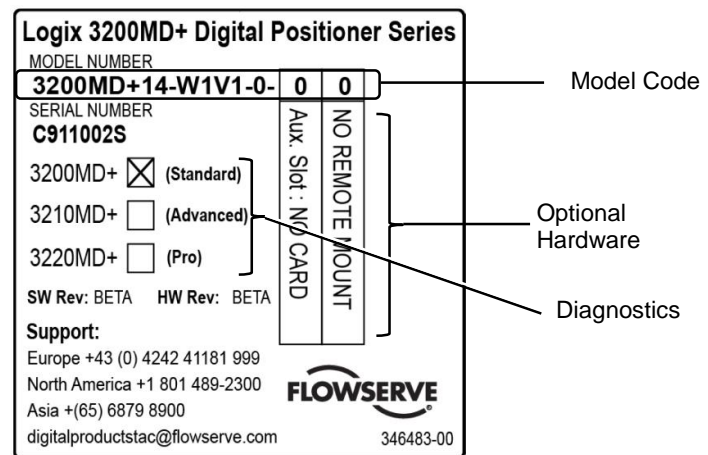

Figure 2: Model Code Label

4 LOGIX 3200+ MODIFICATION

The Logix 3200MD+ positioners are generally delivered as tested and assembled units.

➤ **NOTE:** *Unauthorized modification of the Logix 3200MD+ positioner voids the product test certification and product warranties, could drastically affect product performance, and could be hazardous to personnel and equipment.*

➤ **NOTE:** *Before Logix 3200MD+ re-use, all necessary tests must be repeated and recorded in compliance with all test routines, guidelines and engineering standards.*

5 SAFETY

The safety terms DANGER, CAUTION and NOTE are used in these instructions to highlight particular dangers and/or to provide additional information on aspects that may not be readily apparent.

➤ **NOTE:** *Indicates and provides additional technical information, which may not be very obvious even to qualified personnel.*

 **CAUTION:** *Indicates that minor personal injury and/or property damage can occur if proper precautions are not taken.*

 **DANGER:** *Indicates that death, severe personal injury and/or substantial property damage can occur if proper precautions are not taken.*

Compliance with other, not particularly emphasized notes, with regard to assembly, operation and maintenance and technical documentation (e.g., in the operating instruction, product documentation or on the product itself) is essential in order to avoid faults, which in themselves might directly or indirectly cause severe personal injury or property damage.

6 PACKAGING & TRANSPORT

➤ **NOTE:** *Pay close attention to shipping marks and transport pictograms.*

Careful packing, loading and transport arrangements are required to prevent products from being damaged during transport. Standard packaging includes a cardboard box, with or without a wooden pallet base as needed. Special packaging may include a wooden box. Packaging may use cardboard, plastic wrap, foam, or paper as packing material. Filling material may be a carton type or paper.

Shipping marks display product and package dimensions and weight. Packing guidelines follow HPE standards. (Non-returnable packaging may contain up to 90% recyclable materials.

7 STORAGE

➤ **NOTE:** *Maximum storage time for control valves is 6 months. The packing box begins to break down after 6 months. Leakage may develop.*

Upon arrival on site, store the Logix 3200MD+ on a solid base in a cool, dry, closed room. Until its installation, the valve must be protected from the weather, dirt and other potentially harmful influences.

Do not remove protective covers from the instrument ports until the positioner is ready for installation at the site.

8 UNPACKING

While unpacking the valve and/or Logix® 3200MD+ positioner, check the packing list against the materials received. Lists describing the system and accessories are included in each shipping container.

In the event of shipping damage, contact the shipper immediately. Should any problems arise, contact a Flowserve Flow Control Division representative.

9 PRE-INSTALLATION INSPECTION

When installing a positioner, verify the shaft has not been damaged and that the plugs and cover are in place. The plugs keep debris and moisture from damaging the internal components of the positioner. If the positioner has been contaminated, clean the positioner components gently with a soft damp cloth. Some components may be removed for better access. See section **Error! Reference source not found.:** **Error! Reference source not found..** When cleaning the Double Acting Relay (Spool and Block) take care not to bend or force the spool. Check connectors to ensure that no debris is present. Port screens can be removed with a flat screwdriver for access to internal passages.

10 PROTECTIVE CLOTHING

FLOWSERVE positioners use high pressure gas to operate. Use eye protection when working around pressurized equipment. Follow proper procedures for working with natural gas if it is used.

⚠ DANGER: *Standard industry safety practices must be adhered to when working on this or any process control product. Specifically, personal protective equipment must be used as warranted.*

11 QUALIFIED PERSONNEL

Qualified personnel are people who, on account of their training, experience, instruction and their knowledge of relevant standards, specifications, accident prevention regulations and operating conditions, have been authorized by those responsible for the safety of the plant to perform the necessary work and who can recognize and avoid possible dangers.

In unpacking, installing and performing maintenance as required on FLOWSERVE products, product users and maintenance personnel should thoroughly review this manual prior to installing, operating or performing any maintenance.

12 VALVE & ACTUATOR VARIATIONS

These instructions cannot claim to cover all details of all possible product variations, nor can they provide information for every possible example of installation, operation or maintenance. This means that the instructions normally include only the directions to be followed by qualified personal where the product is being used for its defined purpose. If there are any uncertainties in this respect particularly in the event of missing product-related information, clarification must be obtained via the appropriate Flowserve sales office.

13 SPARE PARTS

Use only FLOWSERVE original spare parts. FLOWSERVE cannot accept responsibility for any damages that occur from using spare parts or fastening materials from other manufactures. If FLOWSERVE products (especially sealing materials) have been in storage for longer periods check these for corrosion or deterioration before using these products. See section **Error! Reference source not found. Error! Reference source not found.** for more information.

14 SERVICE / REPAIR

To avoid possible injury to personnel or damage to products, safety terms must be strictly adhered to. Modifying this product, substituting non-factory parts, or using maintenance procedures other than outlined in this instruction could drastically affect performance and be

hazardous to personnel and equipment, and may void existing warranties.

Between actuator and valve there are moving parts. To avoid injury FLOWSERVE provides pinch-point-protection in the form of cover plates, especially where side-mounted positioners are fitted. If these plates are removed for inspection, service or repair special attention is required. After completing work the cover plates must be refitted.

Logix® 3200MD+ positioner repair is limited to the replacement of sub-assemblies and circuit boards with FLOWSERVE-manufactured replacements as outlined in this manual.

⚠ DANGER: *Substitution of with non-factory positioner components may impair intrinsic safety.*

⚠ CAUTION: *Before products are returned to FLOWSERVE for repair or service, FLOWSERVE must be provided with a certificate which confirms that the product has been decontaminated and is clean. FLOWSERVE will not accept deliveries if a certificate has not been provided (a form can be obtained from FLOWSERVE).*

Apart from the operating instructions and the obligatory accident prevention directives valid in the country of use, all recognized regulations for safety and good engineering practices must be followed.

15 PRINCIPLES OF OPERATION

15.1 Basic Operation

The Logix® 3200MD+ digital positioner is a two-wire 4-20 mA input digital valve positioner which uses the HART protocol to allow two-way remote communications. The positioner is completely powered by the 4-20 mA input signal. Start-up current must be at least 3.9 mA. The positioner is configurable through the local user interface, hand-held or DTM. The Logix® 3200MD+ positioner can control both double- and single-acting pneumatic actuators with linear or rotary mountings.

The Logix® 3200MD+ digital positioner is an electronic and pneumatic closed-loop feedback instrument. Figure 1 shows a schematic of a Logix® 3200MD+ positioner installed on a double-acting linear actuator for air-to-open action.

15.2 HART

The Logix® 3200MD+ receives power from the two-wire, 4-20 mA input signal. However, since this positioner utilizes HART communications, two sources can be used for the command signal: Analog and Digital. In Analog source, the 4-20 mA signal is used for the command source. In Digital source, the level of the input 4-20 mA signal is ignored (used only for power) and a digital signal, sent via the HART communication protocol, is used as the command source. The command source can be accessed with ValveSight® software, the HART 475 communicator, or other host software. See Section 10 for more information.

15.3 Position Definition

Whether in Analog or Digital Source, The position at 0% is always defined as the valve in a closed position and 100% is always defined as the valve in an open position. In Analog Source, the 4-20 mA signal is converted to a position (in percent). During loop calibration, the signals corresponding to 0% and 100% are defined.

15.4 Command Input and Final Command

The Command Input signal (in percent) passes through a characterization/limits modifier block. This function is done in software, which allows for in-the-field customer adjustment. The characterization block can apply no adjustment (Linear), one of several pre-defined characterization curve adjustments (including several Equal Percent), or a 21-point Custom Characterization curve adjustment. In Linear mode, the input signal is passed straight through to the control algorithm in a 1:1 transfer. In Equal Percent (=%) mode, the input signal is mapped to a standard rangeability equal percent curve. If Custom Characterization is enabled, the input signal is mapped to a custom, user-defined 21-point output curve. The custom user-defined 21-point output curve is defined using a handheld or ValveSight® software. In addition, two user-defined features, Soft Limits and Tight Shutoff may affect the position. The actual command being used to position the stem after the evaluation of characterization curves and user limits is called the Final Command.

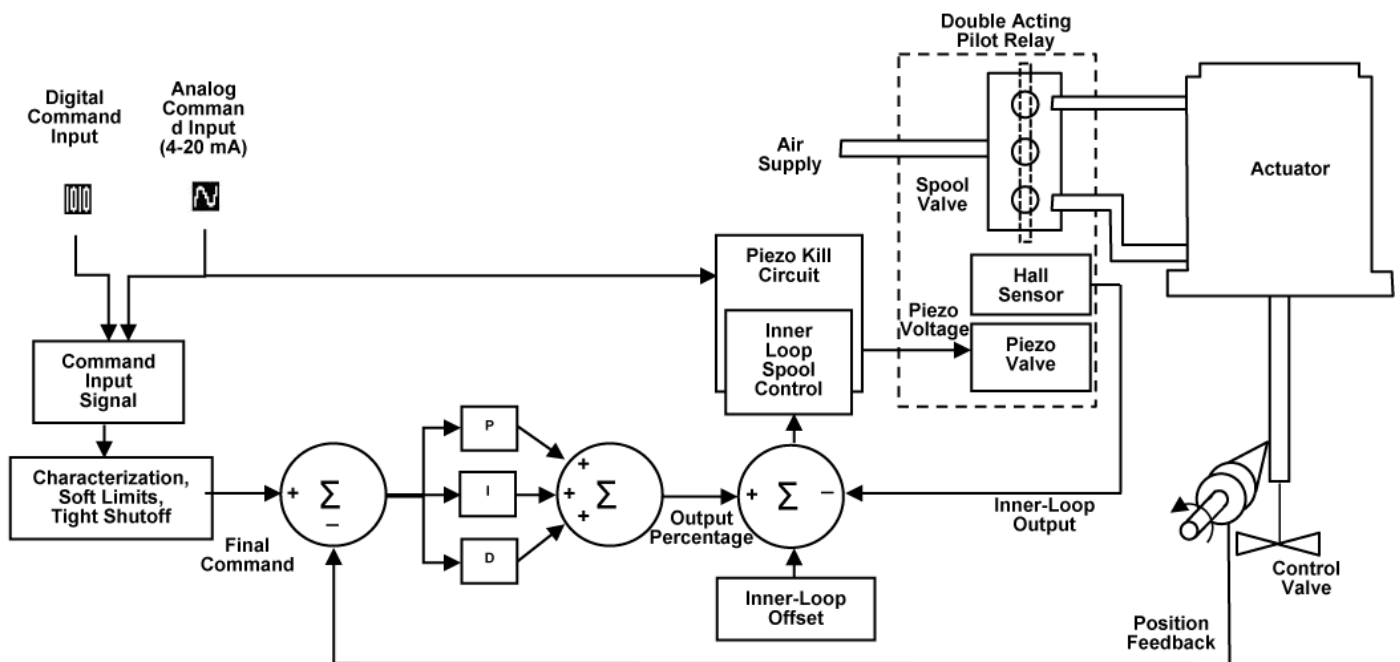

Figure 3: Principles of Operation of Logix 3200MD+

15.5 Outer Loop

The Logix® 3200MD+ uses a two-stage, stem-positioning algorithm. The two stages consist of an inner-loop (pilot relay control) and an outer-loop (stem position control). Referring to Figure 1, a stem position sensor provides a measurement of the stem movement. The Final Command is compared against the Stem Position. If any deviation exists, the control algorithm sends a signal to the inner-loop control to move the relay in a direction, depending upon the deviation. The inner-loop then quickly adjusts the spool position. The actuator pressures change and the stem begins to move. The stem movement reduces the deviation between Final Command and Stem Position. This process continues until the deviation goes to zero.

15.6 Inner Loop

The inner-loop controls the position of the relay valve by means of a driver module. The driver module consists of a temperature-compensated hall-effect sensor and a Piezo valve pressure modulator. The Piezo valve pressure modulator controls the air pressure under a diaphragm by means of a Piezo beam bender. The Piezo beam deflects in response to an applied voltage from the inner-loop electronics. As the voltage to the Piezo valve increases, the Piezo beam bends, closing off against a nozzle causing the pressure under the diaphragm to increase. As the pressure under the diaphragm increases or decreases, the spool valve moves up or down respectively. The Hall Effect sensor transmits the position of the spool back to the inner-loop electronics for control purposes.

15.7 Detailed Sequence of Positioner Operations

A more detailed example explains the control function. See **Error! Reference source not found.2**. Assume the unit is configured as follows:

- Unit is in Analog command source.
- Custom characterization is disabled (therefore characterization is Linear).
- No soft limits enabled. No MPC set.
- Valve has zero deviation with a present input signal of 12 mA.
- Loop calibration: 4 mA = 0% command, 20 mA = 100% command.
- Actuator is tubed and positioner is configured air-to-open.

Given these conditions, 12 mA represents a Command source of 50 percent. Custom characterization is disabled so the command source is passed 1:1 to the Final Command. Since zero deviation exists, the stem position is also at 50 percent. With the stem at the desired position, the spool valve will be at a middle position that balances

the pressures above and below the piston in the actuator. This is commonly called the null or balanced spool position.

Assume the input signal changes from 12 mA to 16 mA. The positioner sees this as a command source of 75 percent. With Linear characterization, the Final Command becomes 75 percent. Deviation is the difference between Final Command and Stem Position: $\text{Deviation} = 75\% - 50\% = +25\%$, where 50 percent is the present stem position. With this positive deviation, the control algorithm sends a signal to move the spool up from its present position. As the spool moves, the supply air is applied to the bottom of the actuator and air is exhausted from the top of the actuator. This new pressure differential causes the stem to start moving towards the desired position of 75 percent. As the stem moves, the Deviation begins to decrease. The control algorithm begins to reduce the spool opening. This process continues until the Deviation goes to zero. At this point, the spool will be back in its null or balanced position. Stem movement will stop and the desired stem position is now achieved.

15.8 Inner Loop Offset

The position of the spool at which the pressures are balanced, holding the valve position in a steady state, is called the Inner Loop Offset. The controlling algorithm uses this value as a reference in determining the Piezo voltage. This parameter is important for proper control and is optimized and set automatically during stroke calibration.

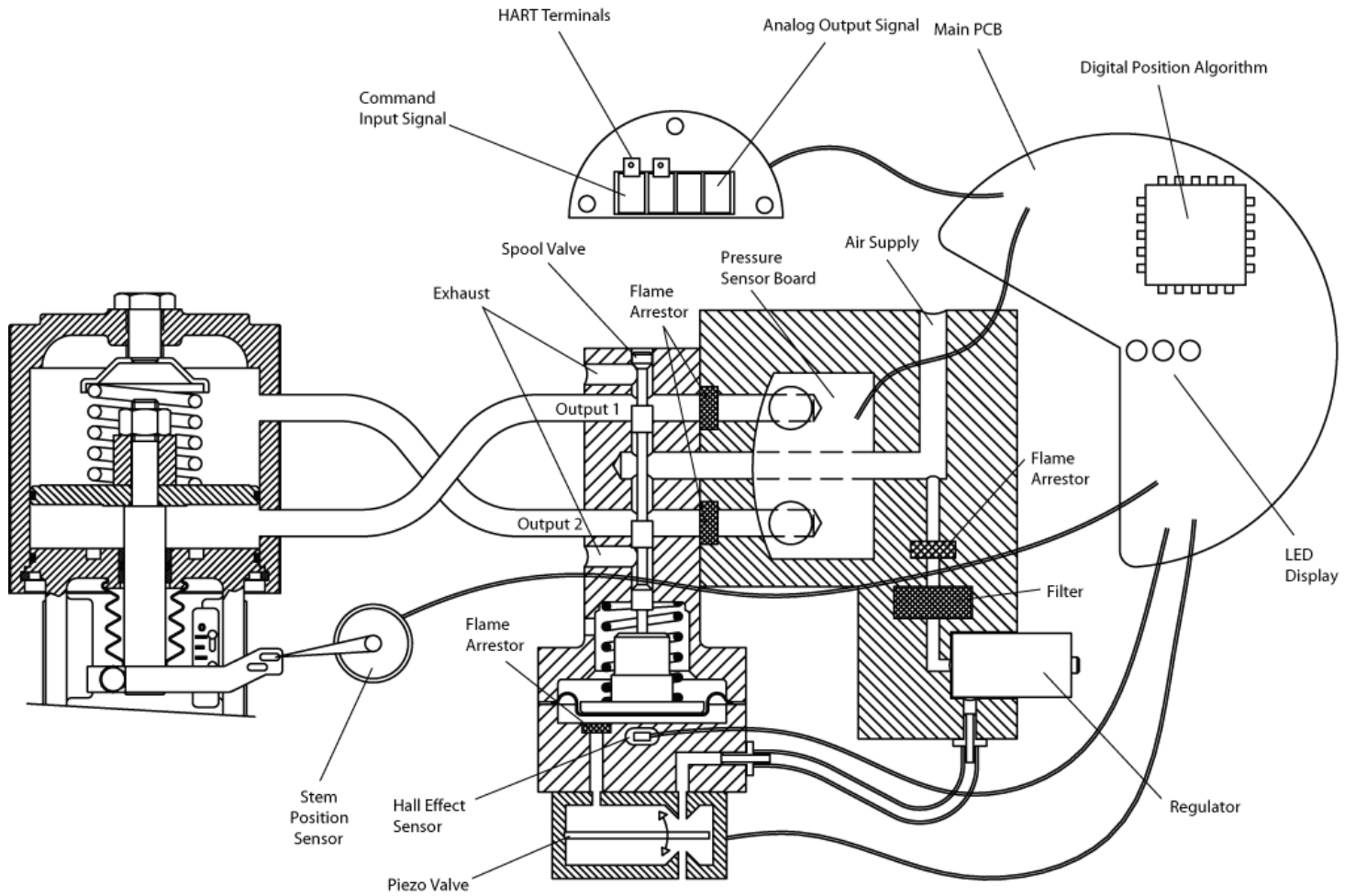

Figure 4: Logix 3200MD+ Digital Positioner Schematic (Double Acting Relay - Air To Open)

16 SPECIFICATIONS

16.1 Input Signal

Table 1: Input Signal	
	Positioner Alone or with Multi-Function Card
Power Supply	Two-wire, 4-20 mA 10.0 VDC plus line losses.
Input Signal Range	4 - 20 mA (HART)
Compliance Voltage	10.0 VDC @ 20 mA
Effective Resistance	500 Ω @ 20 mA Typical
Minimum Required Operating Current	3.9 mA
Maximum Shut-down Current	3.6 mA
Power Interruption Time Limit	After power has been applied for at least 10 seconds, a 60 ms power interruption will not cause the positioner to reset.
Power-up time	Time from application of power to begin controlling valve < 1.0 second.
Communications	HART protocol

16.2 Pneumatic Output

Table 2: Pneumatic Output	
Output Pressure Range	0 to 100% of air supply pressure.
Output Air Capacity	14.3 Nm³/h @ 1.5 bar (8.44 SCFM @ 22 PSI) 30.6 Nm³/h @ 4.1 bar (18.0 SCFM @ 60 PSI)
Primary Output Ports (Port is pressurized in energized state. Port is exhausted upon loss of power.)	Double Acting Relay – Port 1

16.3 Air Supply

Table 3: Air Supply	
Minimum Input Pressure	2.1 Bar (30 PSI)
Maximum Input Pressure	10.3 Bar (150 PSI)
Air Supply Quality	The air supply must be free from moisture, oil and dust by conforming to the ISA 7.0.01 standard. (A dew point at least 18 degrees Fahrenheit below ambient temperature, particle size below five microns—one micron recommended—and oil content not to exceed one part per million).
Operating Humidity	0 - 100% non-condensing
Acceptable Supply Gasses	Air, sweet natural gas, nitrogen and CO2 are acceptable supply gasses. Sour natural gas is not acceptable. For Type nA and Type tb installation only air or inert gas may be connected to the air supply inlet.
Air Consumption	0.5 Nm³/h @ 4 bar (0.3 SCFM @ 60 PSI)
Air Delivery	12 SCFM @ 60 PSI (0.27 Cv)

16.4 Analog Output – Multi-Function Card

Table 4: 4 to 20 mA Analog Output Specification	
For entity parameters, see section 17 HAZARDOUS AREA CERTIFICATIONS.	
Power Supply Range	10.0 to 40 VDC, (24 VDC Typical)
Current Signal Output	4 to 20 mA
Linearity	1.0% F.S.
Repeatability	0.25% F.S.
Hysteresis	1.0% F.S.
Operating Temperature	-52 to 85°C (-61.6 to 185°F)

16.5 Stroke Output

Table 5: Stroke Output	
Feedback shaft Rotation	Min 15°, Max 90° 45° recommended for linear applications.

16.6 Remote Mount Specifications

Table 6: Remote Mount Specifications	
For entity parameters, see section 17 HAZARDOUS AREA CERTIFICATIONS.	
Remote Mount Device	Use only with Logix® Remote Mount Option device.
Max Cable and Tube Distance	30.5 m (100 ft)
Operating Temperature	-52 to 85°C (-61.6 to 121°F)

16.7 Positioner Performance Characteristics

Table 7: Performance Characteristics	
Better than or equal to the following values on a 25 square inch Mark One actuator.	
Resolution	≤ 0.25%
Linearity	≤ 0.8% full scale
Repeatability	≤ 0.05% full scale
Hysteresis	≤ 1.0%
Deadband	≤ 0.1% full scale
Sensitivity	≤ 0.25%
Stability	≤ 0.4%
Long term drift	≤ 0.5%
Supply Pressure Effect	≤ 0.2%

NOTE: Performance tested according to ISA 75.13.

16.8 Physical Specifications

Table 8: Physical Specifications	
For dimensions, see section 30 POSITIONER DIMENSIONS	
Housing Material	Cast, powder-painted aluminum EN AC-AISI12(Fe)
Soft Goods	Fluorosilicone
Weight of Base Positioner Without Accessories	3.9 kg (8.3 lb) aluminum

16.9 Temperature

Table 9: Temperature	
Operating Temperature Range	-52 to 85°C (-61.6 to 185°F)
Transport and Storage Range	-52 to 85°C (-61.6 to 185°F)

NOTE: Reduced performance possible at low temperatures.

16.10 ValveSight® DTM Software Specifications

Table 10: ValveSight® DTM Software Specifications	
Computer	Minimum Pentium processor running Windows 2000, XP, Server 2003, Server 2003 R2, Server 2008 (32-bit & 64-bit Versions), Server 2008 R2 (32-bit & 64-bit Versions), and 7 (32-bit & 64-bit Versions). Memory: >64MB Available HARD Disk Space : >64MB
Ports	1 minimum available with 8 maximum possible. (Can also communicate via serial, PCMCIA and USB connections)
HART Modem	RS-232, PCMCIA card, or USB
HART Filter	May be required in conjunction with some DCS hardware.
HART MUX	MTL 4840/ELCON 2700, P&F K System HART Multiplexer

17 HAZARDOUS AREA CERTIFICATIONS

DANGER: Certifications listed on the positioner are correct for that positioner. Before using the information on this page, ensure the certifications on the positioner label match the certifications on this page.

Table 11: Logix® 3200MD+ Series Hazardous Locations Information

<p style="text-align: center;">North America (FM/CSA)</p> <p>Explosion Proof Class I, Div 1, Groups B,C,D Class I, Zone 1, AEx db IIB+H2 T4/T6 Gb IP65 Class I, Zone 1, Ex db IIB+H2 T4/T6 Gb IP65 Class II, III, Div 1 Groups E,F,G T4 Ta = -50°C to +80°C T6 Ta = -50°C to +45°C</p> <p>Intrinsically Safe Class I,II,III, Div 1, Groups A,B,C,D,E,F,G Class I, Zone 0, AEx ia IIC T4/T6 Ga IP65 Class I, Zone 0, Ex ia IIC T4/T6 Ga IP65 T4 Ta = -52°C to +85°C T6 Ta = -52°C to +45°C</p> <p>Non-Incendive Class I, Div 2, Groups A,B,C,D T4 Ta = -52°C to +85°C T6 Ta = -52°C to +45°C</p>	<p style="text-align: center;">ATEX</p> <p>Flame Proof FM16ATEX0006X II 2 G Ex db IIB+H2 T4/T6 Gb IP65 T4 Ta = -52°C to +80°C T6 Ta = -52°C to +45°C</p> <p>Type “t” FM16ATEX0006X II 2 D Ex tb IIIC T95°C Db IP65 Ta = -52°C to +55°C</p> <p>Intrinsically Safe FM16ATEX0021X II 1 G Ex ia IIC T4/T6 Ga IP65 T4 Ta = -52°C to +80°C T6 Ta = -52°C to +45°C</p> <p>II 1 D Ex ia IIIC T95°C Da IP65 Ta = -52°C to +85°C</p> <p>Type “n” FM16ATEX0027X II 3 G Ex nA IIC T4/T6 Gc IP65 T4 Ta = -52°C to +80°C T6 Ta = -52°C to +45°C</p>
<p style="text-align: center;">Nema Type 4X, IP65</p>	<p style="text-align: center;">IECEX</p> <p>Explosion Proof IECEX FMG 16.0007X Ex db IIB+H2 T4/T6 Gb IP65 T4 Ta = -52°C to +80°C T6 Ta = -52°C to +45°C</p> <p>Type “t” IECEX FMG 16.0007X Ex tb IIIC T95°C Db IP65 Ta = -52°C to +55°C</p> <p>Intrinsically Safe & Type “n” IECEX FMG 16.0015X Ex ia IIC T4/T6 Ga IP65 T4 Ta = -52°C to +85°C T6 Ta = -52°C to +45°C</p> <p>Ex nA IIC T4/T6 Gc IP65 T4 Ta = -52°C to +85°C T6 Ta = -52°C to +45°C</p>

Warning!

- Covers must be properly installed in order to maintain environmental ratings.

Special Conditions for Safe Use:

- The equipment must be installed in such a manner as to minimize the risk of impact or friction with other metal surfaces.
- To avoid possibility of static discharge clean only with a damp cloth.
- For Intrinsically Safe installations the positioner must be connected to suitably rated intrinsically safe equipment, and must be installed in accordance with applicable intrinsically safe installation standards.
- Substitution of components may impair Intrinsic Safety.
- Use appropriately rated cable insulation at higher temperatures.
- Contact Flowserve for flame path information.
- For Type nA and Type tb installation only air or inert gas may be connected to the air supply inlet.
- Provisions shall be made externally to provide transient overvoltage protection to a level not to exceed 140% of the peak rated input voltage.
- Using the box provided on the nameplate, the User shall permanently mark the type of protection chosen for the specific installation. Once the type of protection has been marked it shall not be changed

Conditions spéciales pour une utilisation en toute sécurité:

- Le matériel doit être installé de sorte à réduire au minimum le risque de choc ou de frottement avec d'autres surfaces métalliques.
- Pour éviter les risques de décharge d'électricité statique Nettoyez uniquement avec un chiffon humide.
- Pour les installations en sécurité intrinsèque, le positionneur doit être connecté à un équipement sécurité intrinsèque convenablement qualifié, et doit être installé conformément aux normes d'installation sécurité intrinsèque applicables.
- La substitution de composants peut compromettre la sécurité intrinsèque.
- Utiliser une isolation appropriée du câble à des températures plus élevées.
Contactez Flowserve pour les informations de trajet de flamme.

Assessed to the following ATEX standards: EN 60079-0 :2012, EN 60079-11 :2012, EN 60079-1:2007, EN 60079-31:2009, EN 60529: 1991/A1:2001

Assessed to the following IECEx standards: IEC 60079-0: 2011, IEC 60079-11: 2011, IEC 60529: 1999, IEC 60079-1: 2007-04, IEC 60079-31:2013

Assessed to the following US standards: FM Class 3600 :2011, Class 3610 :2010, FM Class 315:2006, FM Class 3616:2011, FM Class 3810: 2005, ANSI/ISA 60079-0:2013, ANSI/ISA 60079-11:2014, ANSI/NEMA 250:2003, ANSI/IEC 60529:2004, INSI/ISA 60079-1: 2009

18 MOUNTING AND INSTALLING

18.1 Mounting to Mark One Linear Valves

To mount a Logix® 3200MD+ positioner to a Valtek linear Mark One valve, refer to **Error! Reference source not found.** and proceed as outlined below.

- 1 Remove washer and nut from follower pin assembly. Insert pin into the appropriate hole in follower arm, based on stroke length. The stroke lengths are stamped next to their corresponding holes in the follower arms. Make sure the unthreaded end of the pin is on the stamped side of the arm. Reinstall lock washer and tighten nut to complete follower arm assembly.
- 2 Slide the slot in the follower arm assembly over the flats on the position feedback shaft in the back of the positioner. Make sure the arm is pointing toward the customer interface side of the positioner. Slide the lock washer over the threads on the shaft and tighten down the nut.
- 3 Align the bracket with the three outer mounting holes on the positioner. Fasten with 1/4" bolts.
- 4 Place a washer over one of the mounting bolts. Screw one mounting bolt into the hole on the yoke mounting pad nearest the valve. Stop when the bolt is approximately 3/16" from being flush with mounting pad.
- 5 Slip the large end of the teardrop shaped mounting hole in the back of the positioner/bracket assembly over the mounting bolt. Slide the small end of the

teardrop under the mounting bolt and align the upper mounting hole.

- 6 Insert the upper mounting bolt and tighten the bolting.
 - 7 Position the take-off arm mounting slot against the stem clamp mounting pad. Apply Loctite 222 to the take-off arm bolting and insert through washers into stem clamp. Leave bolts loose.
 - 8 Slide the appropriate pin slot of the take-off arm, based on stroke length, over the follower arm pin. The appropriate stroke lengths are stamped by each pin slot.
- **NOTE:** *The feedback shaft has a clutch mechanism that allows for over-rotation of the shaft for easy adjustments.*
- 9 Center the take-off arm on the rolling sleeve of the follower pin.
 - 10 Align the take-off arm with the top plane of the stem clamp and tighten bolting. Torque to 120 in-lb.

➤ **NOTE:** *If mounted properly, the follower arm should be horizontal when the valve is at 50% stroke and should move approximately $\pm 30^\circ$ from horizontal over the full stroke of the valve. If mounted incorrectly, a stroke calibration error will occur and the indicator lights will blink a RGGY code indicating the position sensor has gone out of range on one end of travel or the travel is too small. Reposition the feedback linkage or rotate the position sensor to correct the error.*

➤ **NOTE:** *To virtually eliminate non-linearity, use the Linearization feature in the Custom Characterization page of the DTM.*

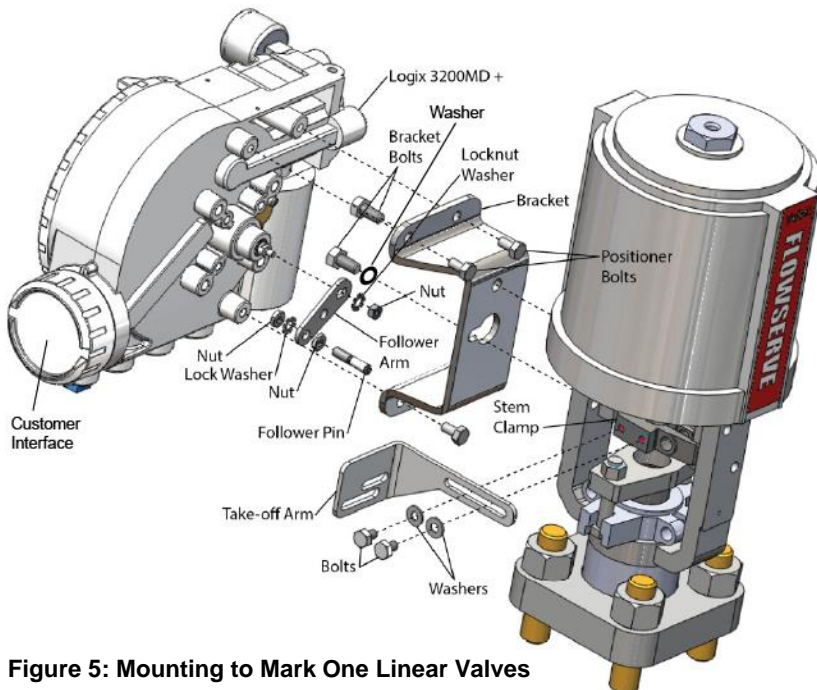

Figure 5: Mounting to Mark One Linear Valves

18.2 Mounting to Standard Valtek Rotary Valves

The standard rotary mounting applies to Valtek valve/actuator assemblies that do not have mounted volume tanks or hand-wheels. The standard mounting uses a linkage directly coupled to the valve shaft. This linkage has been designed to allow for minimal misalignment between the positioner and the actuator. Refer to **Error! Reference source not found.**6 through 9.

- 1 Fasten the spline lever adapter to the splined lever using two 6 x 1/2" self-tapping screws.
- 2 Attach follower arm to positioner feedback shaft using the star washer and 10-32 nut.
- 3 Determine the rotation of the valve. Slide the take-off arm onto the spline lever adapter shaft. Orient the take-off arm to the starting point of the valve rotation and make sure that it will match up with the rotational range of the positioner follower arm. Insert the screw with star washer through the take-off arm and add the second star washer and nut and tighten.
- 4 Using four 1/4-20 x 1/2" bolts, fasten positioner to universal bracket using appropriate hole pattern (stamped on bracket).
- 5 Using a 1/2" end wrench and two 5/16-18 X 1/2" bolts, attach bracket to actuator transfer case pad. Leave these bolts slightly loose until final adjustments are made.

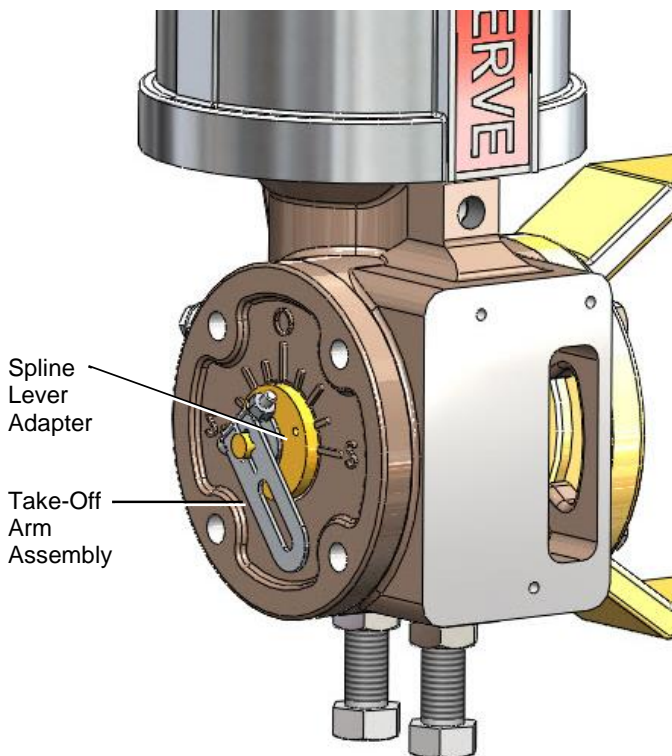

Figure 6: Valtek Rotary Take-Off Arm

- 6 Rotate the follower arm so the follower pin will slide into the slot on the take-off arm. Adjust the bracket position as needed noting the engagement of the follower pin and the take-off arm slot. The pin should extend approximately 2 mm past the take-off arm. When properly adjusted, securely tighten the bracketing bolts.
- 7 Rotate follower arm so the follower pin will slide into the slot on the take-off arm. Over-rotate the follower arm if needed so the arm moves freely through the intended travel.

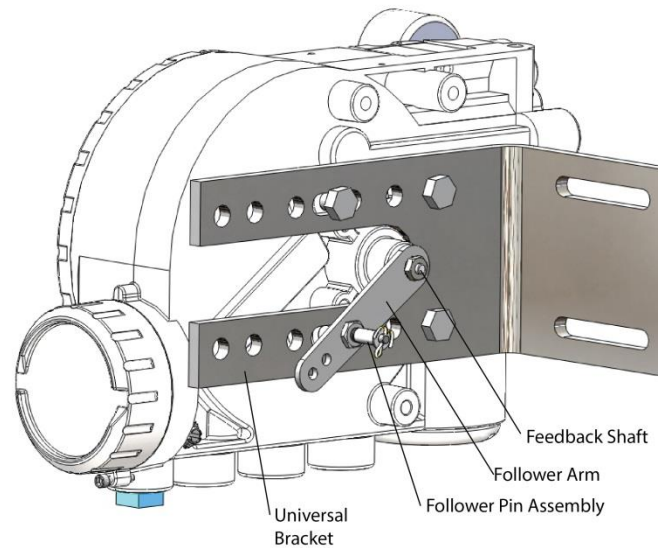

Figure 7: Valtek Rotary Follower Arm

⚠ **NOTE:** The feedback shaft has a clutch mechanism that allows for over-rotation of the shaft for easy adjustments.

- 8 Adjust the bracket position as needed noting the engagement of the follower pin and the take-off arm slot. The pin should extend approximately 1/16" past the take-off arm. When properly adjusted, securely tighten the bracketing bolts.

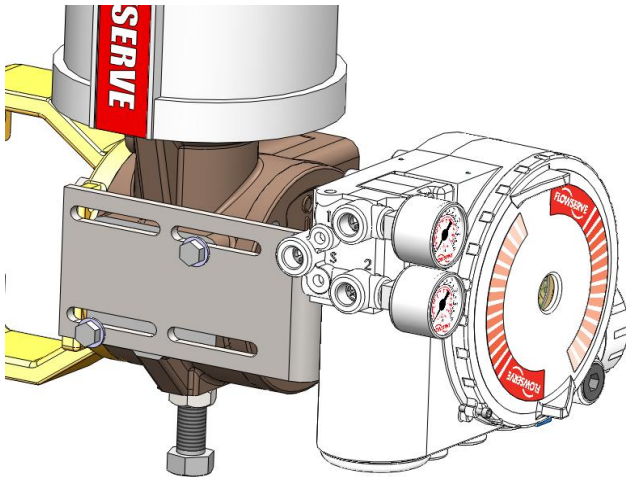

Figure 8: Valtek Rotary Mounting

- 9 Connect regulated air supply to appropriate port in manifold. See section 19 TUBING.
- 10 Connect the power to the 4-20 mA terminals. See section 20 ELECTRICAL CONNECTIONS.
- 11 Remove main cover and locate DIP switches and QUICK-CAL/ACCEPT button.
- 12 Refer to sticker on main board cover and set DIP switches accordingly. See section 21 STARTUP.
- 13 Press the QUICK-CAL/ACCEPT button for three to four seconds or until the positioner begins to move. The positioner will now perform a stroke calibration.
- 14 If the calibration was successful the green LED will blink GGGG or GGGY and the valve will be in control mode.
- 15 If calibration fails, as indicated by a RGGY blink code, retry the calibration. If it still fails, the feedback values were exceeded and the arm must be adjusted away from the positioner's limits. Rotate the feedback shaft so that the full free travel of the feedback shaft is in the range of the actuator movement. Optionally, continue to attempt the calibration. Each calibration attempt adjusts the acceptable limits and it should pass eventually.

⚠ CAUTION: Remember to remove the air supply before re-adjusting take-off arm.

👉 NOTE: If mounted properly, the follower arm should be horizontal when the valve is at 50% stroke and should move approximately $\pm 30^\circ$ from horizontal over the full stroke of the valve.

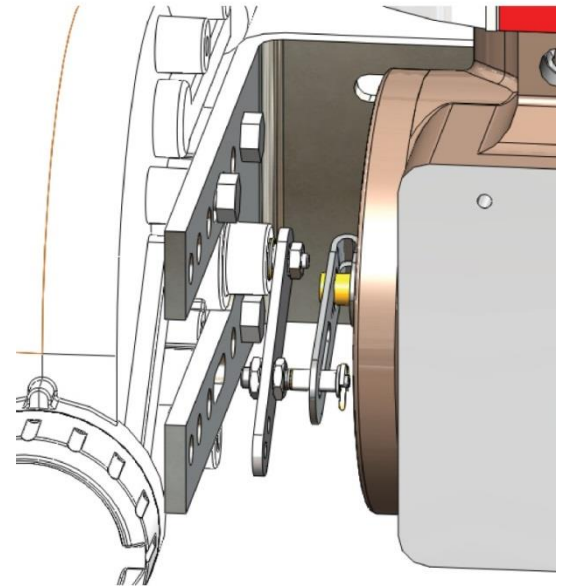

Figure 9: Valtek Rotary Final Orientation

👉 NOTE: To virtually eliminate non-linearity, use the Linearization feature on the Custom Characterization page of the DTM.

18.3 Optional Valtek Rotary Mounting Procedure

- 1 Using a 1/2" open-end wrench and two 5/16-18 x 1/2" bolts, attach bracket to actuator transfer case pads. Leave bracket loose to allow for adjustment
- 2 Using four 1/4-20x 1/2" bolts and a 7/16" open-end wrench, fasten positioner to universal bracket, using the four-hole pattern that locates the positioner the farthest from the valve. Rotate positioner 90 degrees from normal so gauges are facing upward.
- 3 Attach follower arm to positioner feedback shaft, using the star washer and 10-32 nut.
- 4 Attach tripper and tripper clamp to valve shaft using two 1/4-20 bolts and two 1/4-20 locknuts. Leave tripper loose on shaft until final adjustment.
- 5 Thread ball joint linkage end to tripper and tighten (thread locking compound such as Loctite is recommended to prevent back threading). Adjust the length of tie rod so follower arm and tripper rotate parallel to each other (rod must be cut to the desired length). Connect the other ball joint end to follower arm using a star washer and a 10-32 nut.
- 6 Tighten bracket and tripper bolting.
- 7 Check for proper operation, not direction or rotation.

➤ **NOTE:** The feedback shaft has a clutch mechanism that allows for over-rotation of the shaft for easy adjustments.

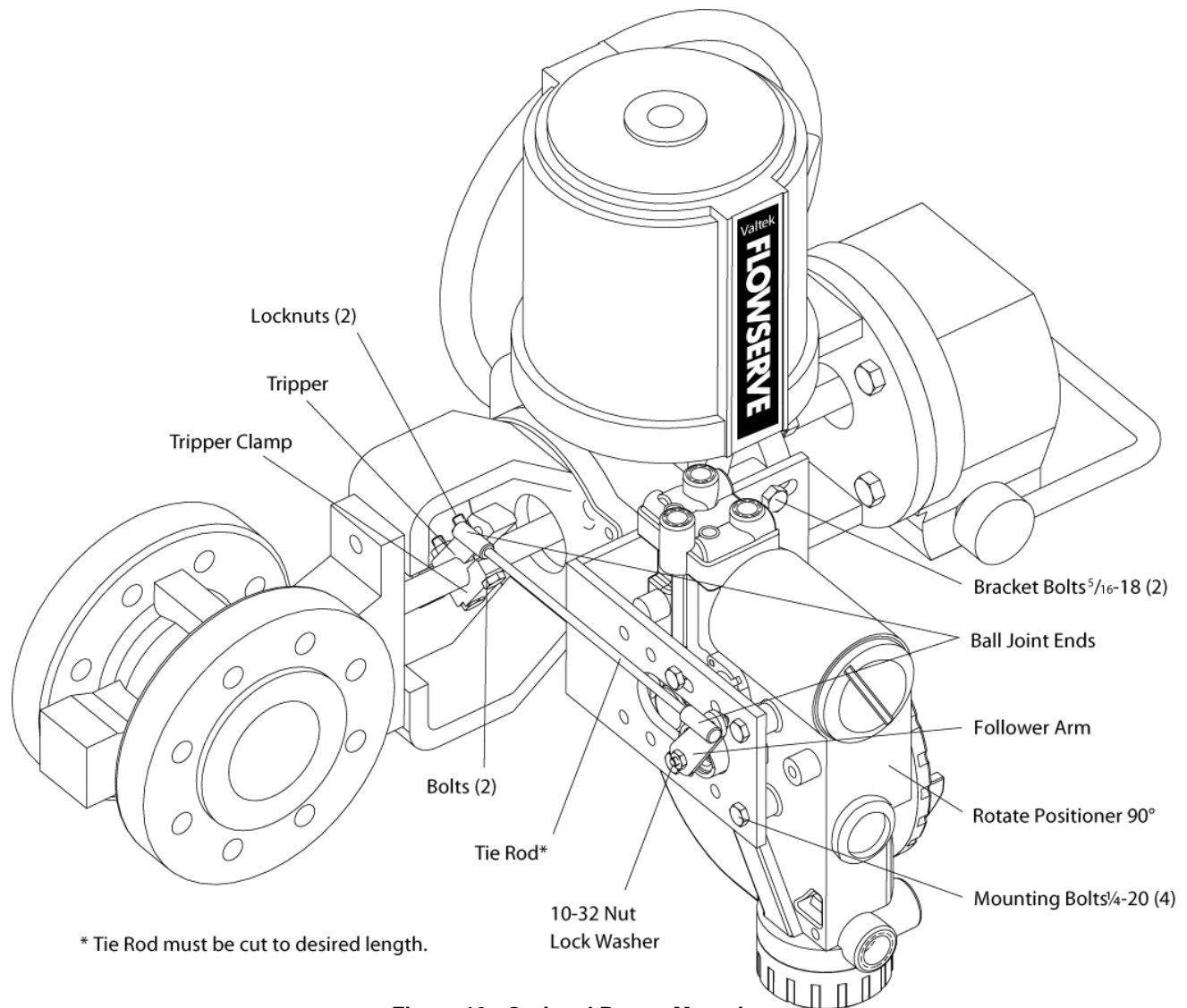

Figure 10: Optional Rotary Mounting

18.4 Mounting to Rotary NAMUR (AutoMax) Valves

- 1 Attach the mounting plate to the positioner using 4 screws. See Figure 11.
- 2 Rotate the feedback shaft to match the orientation of the receiver on the actuator.
- **NOTE:** *The feedback shaft has a clutch mechanism that allows for over-rotation of the shaft for easy adjustments.*
- 3 Mount the positioner onto the actuator using the washers and nuts. See Figure 12.
- 4 Connect regulated air supply to appropriate port in manifold. See section 19 TUBING.
- 5 Connect the power to the 4-20 mA terminals. See section 20 ELECTRICAL CONNECTIONS.
- 6 Remove main cover and locate DIP switches and QUICK-CAL/ACCEPT button.
- 7 Refer to sticker on main board cover and set DIP switches accordingly. See section 21 STARTUP.
- 8 Press the QUICK-CAL/ACCEPT button for three to four seconds or until the positioner begins to move. The positioner will now perform a stroke calibration.
- 9 If the calibration was successful the green LED will blink GGGG or GGGY and the valve will be in control mode.
- 10 If calibration fails, as indicated by a RGGY blink code, retry the calibration. If it still fails, remove power from the positioner, disconnect the air, and remove the positioner from the actuator. Rotate the feedback shaft so that the full free travel of the feedback shaft is in the range of the actuator movement. Optionally, continue to attempt the calibration. Each calibration attempt adjusts the acceptable limits and it should pass eventually.

CAUTION: *Remember to remove the air supply before re-adjusting take-off arm.*

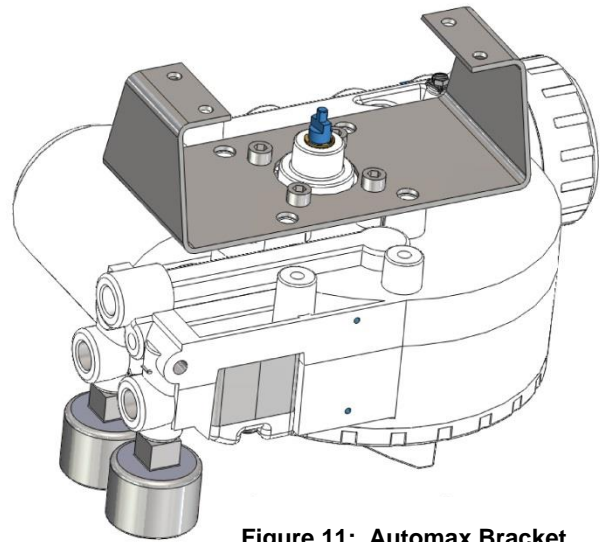

Figure 11: Automax Bracket

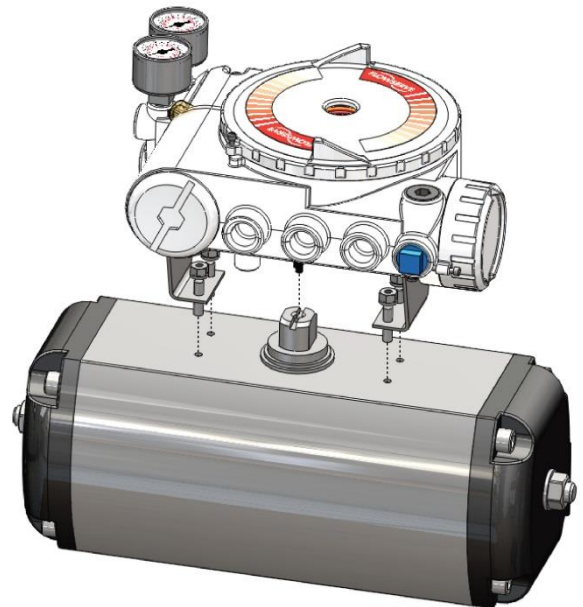

Figure 12: Automax Assembly

19 TUBING

After mounting has been completed, tube the positioner to the actuator using the appropriate compression fitting connectors. For best performance, use 10 mm (3/8 inch) tubing for 645 square cm (100 square inch) actuators or larger. See **Error! Reference source not found.** below.

19.1 Determine Air Action

The port labeled “1” delivers air when an air supply is present and the relay is energized. Typically, the port labeled “1” should be tubed to the pneumatic side of the actuator (the side that would result in the air compressing the actuator spring). When tubed this way, the spring is designed to return the valve to the fail safe state should supply air or power to the unit fail.

Tube the port labeled “1” to the side of the actuator that must receive air to begin moving away from the fail safe state.

If air from “1” should open the valve, set the Air Action configuration switch on the positioner to Air-to-Open, otherwise set it to Air-to-Close.

The Air-to-Open and Air-to-Close selection is determined by the actuator tubing, not the software. When air action selection is made during configuration, the selection tells the control which way the actuator has been tubed.

If the valve is double acting, port the valve labeled “2” to the other side of the actuator.

⚠ DANGER: *Proper tubing orientation is critical for the positioner to function correctly and have the proper failure mode.*

Example: Tubing Linear Double-Acting Actuators

For a linear air-to-open actuator, the “1” port of the positioner is tubed to the bottom side of the actuator (closest to the valve). The “2” port of the positioner is tubed to the top side of the actuator. See **Error! Reference source not found.**13. For a linear air-to-close actuator the tubing configuration is reversed.

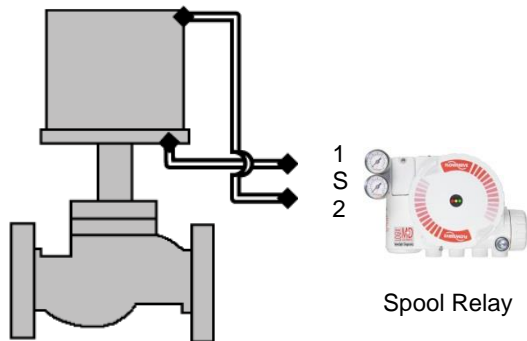

Figure 13: Linear, Double Acting, Air to Open

Example: Rotary Double-Acting Actuators

For a rotary actuator, the “1” port of the positioner manifold is tubed to the far side of the actuator. The “2” port of the positioner manifold is tubed to the side of the actuator closer to the transfer case. This tubing convention is followed regardless of air action. On rotary actuators, the transfer case orientation determines the air action. See Figure 14.

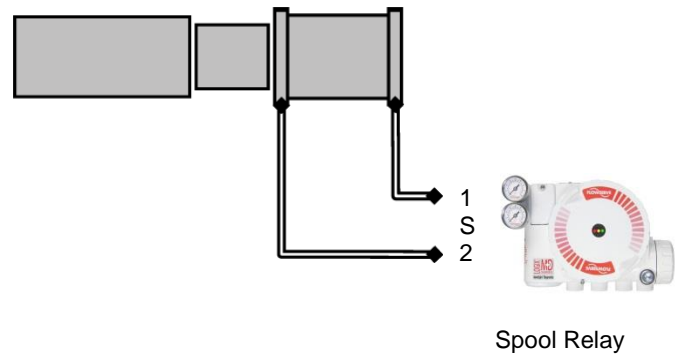

Figure 14: Rotary, Double Acting, Air to Open

Example: Tubing Single-acting Actuators

For single-acting actuators, the “1” port is always tubed to the pneumatic side of the actuator regardless of air action. If a double acting (spool style) relay is installed in the positioner, plug port “2”. See Figure 15.

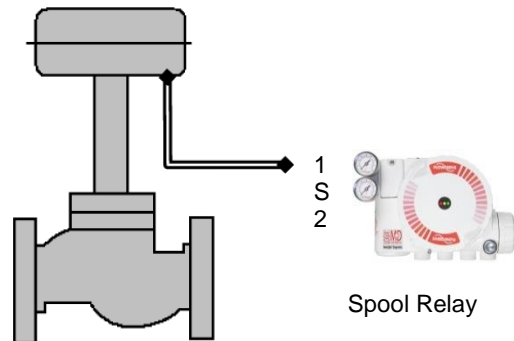

Figure 15: Linear, Single Acting, Air to Open

19.2 Connect Supply Port

The positioner ports are threaded with ¼ NPTF.

In order to maintain the recommended air quality, a coalescing filter should always be installed in the supply gas line. An air filter is highly recommended for all applications where dirty air is a possibility. The positioner passage ways are equipped with small filters, which remove medium and coarse size dirt from the pressurized air. If necessary, they are easily accessible for cleaning.

A supply regulator is recommended if the customer will be using the diagnostic features of the Logix® 3200MD+ but is not required. In applications where the supply pressure is higher than the maximum actuator pressure rating a supply regulator is required to lower the pressure to the actuator's maximum rating.

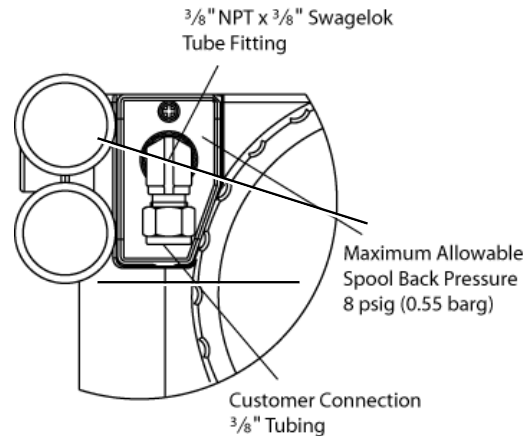

19.3 Vented Design

A standard Logix® 3200MD+ positioner is vented directly to the atmosphere. When supply air is substituted with sweet natural gas, piping must be used to route the exhausted natural gas to a safe environment.

The housing chamber exhaust port is located on the backside of the positioner. The actuator exhaust port is located on the front of the positioner. Both ports are tapped with ¼ NPTF and covered with a protective cap. To control vented gas, remove the caps and connect the necessary tubing/piping to these ports. See **Error! Reference source not found.**

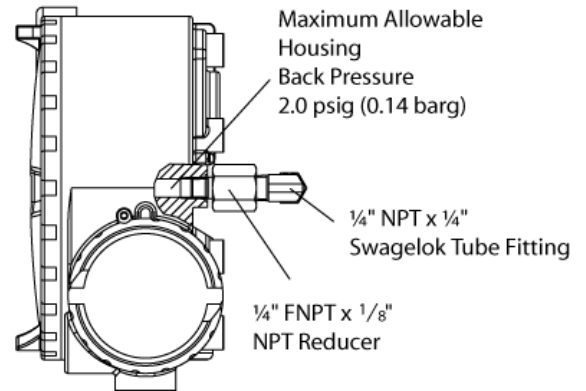

Figure 16: Exhaust Vents

This piping system may cause some positioner back pressure. Back pressure in the housing chamber is from the modulator and regulator. Back pressure in the exhaust port is from the actuator.

The maximum allowable back pressure from the housing chamber is 0.14 barg (2.0 PSIG). For flow rates, see section 16.3 Air Supply.

The maximum allowable back pressure from the exhaust port is 0.55 barg (8.0 PSIG). Higher pressure may result in decreased performance. For output flow rates, see section 16.2 Pneumatic Output.

CAUTION: The back pressure in the main housing must never rise above 0.14 barg (2.0 PSIG). This could cause the positioner to become unresponsive under some circumstances

CAUTION: The natural gas used must be sweet natural gas. Use of sour natural gas may cause positioner to fail prematurely.

Port	Double Acting Configuration	Single Acting Configuration
1	1	1
S	Supply	Supply
2	2	(Plug)

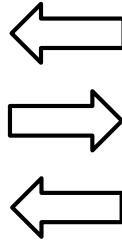

Figure 17: Pneumatic Connections

20 ELECTRICAL CONNECTIONS

20.1 Electrical Terminals

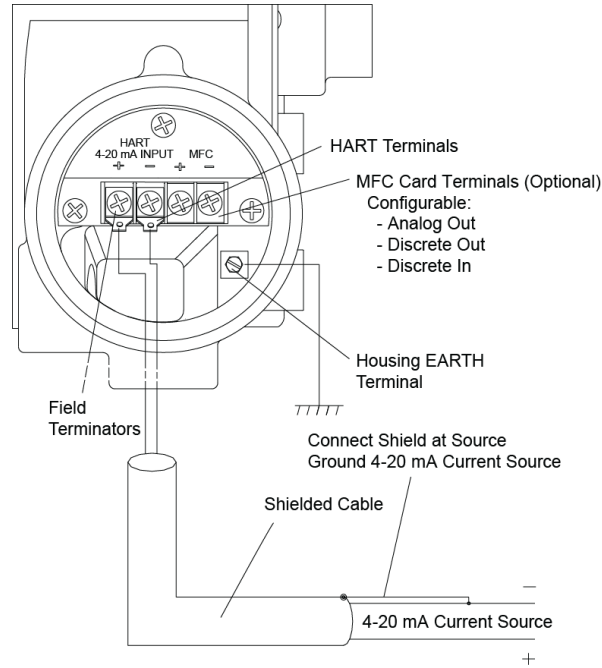

Figure 18: Terminal Diagram

20.2 Command Input (4-20 mA) Connection

The Logix® 3200MD+ is reverse polarity protected, however, verify polarity when making field termination connection. Wire 4-20 mA current source to the input terminal labeled “HART 4-20mA INPUT”. Tighten using 0.5 to 0.6 Nm torque. See **Error! Reference source not found.** Depending on the current source, a HART filter may be required. See 28.1 Troubleshooting Guide.

20.2.1 Compliance Voltage

Output compliance voltage refers to the voltage limit the current source can provide. A current loop system consists of the current source, wiring resistance, barrier resistance (if present), and the Logix® 3200MD+ impedance. The Logix® 3200MD+ requires that the current loop system allow for a 10 VDC drop across the positioner at maximum loop current. The operating current range is from 3.9 to 24 mA.

In order to determine if the loop will support the Logix® 3200MD+, perform the calculation in the following equation. The Available Voltage must be greater than 10VDC in order to support the Logix® 3200MD+. Also, see Table 1: Input Signal.

Equation 1

$$\text{Available Voltage} = \text{Controller Voltage (@Current}_{max}) - \text{Current}_{max} \times (R_{\text{barrier}} + R_{\text{wire}})$$

$$\text{Current}_{max} = 20\text{mA}$$

$$R_{\text{barrier}} = 300\Omega$$

$$R_{\text{wire}} = 25\Omega$$

$$\text{Available Voltage} = 19\text{V} - 0.020\text{A} \times (300\Omega + 25\Omega)$$

$$\text{Available Voltage} = 12.5\text{V}$$

The available voltage (12.5 V) is greater than the required voltage (10.0 V) therefore; this system will support the Logix® 3200MD+. The Logix® 3200MD+ has an input resistance equivalent to 500 Ω at a 20 mA input current.

CAUTION: The current must always be limited for 4-20 mA operation. Never connect a voltage source directly across the Logix® 3200MD+ terminals. This could cause permanent circuit board damage.

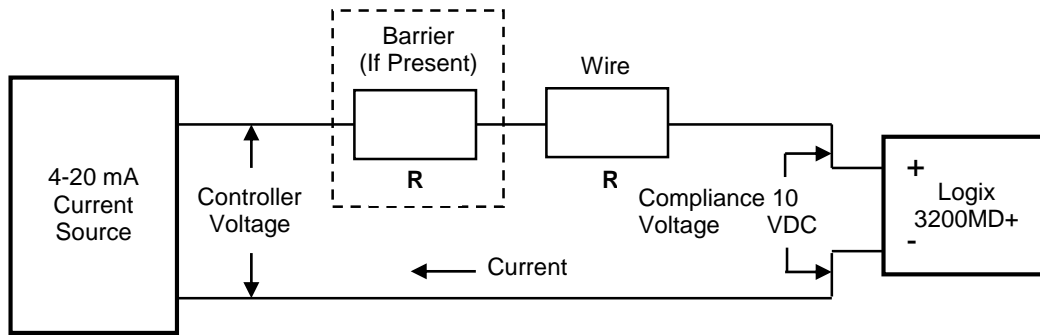

Figure 19: Compliance Voltage

20.2.2 Cable Requirements

The Logix® 3200MD+ digital positioner utilizes the HART Communication protocol. This communication signal is superimposed on the 4-20 mA current signal. The two frequencies used by the HART protocol are 1200 Hz and 2200 Hz. In order to prevent distortion of the HART communication signal, cable capacitance and cable length restrictions must be calculated. The cable length restrictions must be limited if the capacitance is too high. Selecting a cable with lower capacitance/foot rating will allow longer cable runs. In addition to the cable capacitance, t15.1.1 also affects the allowable cable length. See

In order to calculate the maximum network capacitance, use the following formula:

Equation 2

$$C_{\text{network}} (\mu\text{F}) \leq \frac{650\Omega}{(R_{\text{barrier}} + R_{\text{wire}} + 390\Omega)} - 0.0032$$

Example:

$$R_{\text{barrier}} = 300\Omega \text{ (if present)}$$

$$R_{\text{wire}} = 50\Omega$$

$$C_{\text{network}} (\mu\text{F}) \leq \frac{650\Omega}{(300\Omega + 50\Omega + 390\Omega)} - 0.0032 = 0.08 \mu\text{F}$$

In order to calculate the maximum cable length, use the following formula:

Equation 3

$$\text{Max Cable Length} = \frac{C_{\text{network}}}{C_{\text{cable}}}$$

Example:

$$C_{\text{cable}} = 72 \frac{\mu\text{F}}{\text{m}} = .000072 \frac{\mu\text{F}}{\text{m}}$$

$$\text{Max Cable Length} = \frac{0.08 \mu\text{F}}{.000072 \frac{\mu\text{F}}{\text{m}}}$$

$$\text{Max Cable Length} = 1111 \text{ m}$$

To control cable resistance, 24 AWG cable should be used for runs less than 5000 feet. For cable runs longer than 5000 feet, 20 AWG cable should be used.

The input loop current signal to the Logix® 3200MD+ digital positioner should be in shielded cable. Shields must be tied to a ground at only one end of the cable to provide a place for environmental electrical noise to be removed from the cable. In general, shield wire should be connected at the source, not at the positioner.

20.2.3 Intrinsically Safe Barriers

When selecting an intrinsically safe barrier, make sure the barrier is HART compatible. Although the barrier will pass the loop current and allow normal positioner control, if not compatible, it may prevent HART communication.

20.2.4 Grounding and Conduit

The grounding terminals, located by the electrical conduit ports should be used to provide the unit with an adequate and reliable earth ground reference. This ground should be tied to the same ground as the electrical conduit.

Additionally, the electrical conduit should be earth grounded at both ends of its run.

➡ **NOTE:** The grounded screw must not be used to terminate signal shield wires. Shield wires should be terminated only at the signal source.

This product has electrical conduit connections in either thread sizes 1/2" NPTF or M20x1.5 which appear identical but are not interchangeable. The thread size is indicated on the side of the positioner near the conduit connections. Conduit fittings must match equipment housing threads before installation. If threads do not match, obtain suitable adapters or contact a Flowserve representative. See Figure 20: Conduit and Grounding.

➡ **NOTE:** Housings with M20x1.5 conduit threads are not available with Certification Code 34. See Table 24.

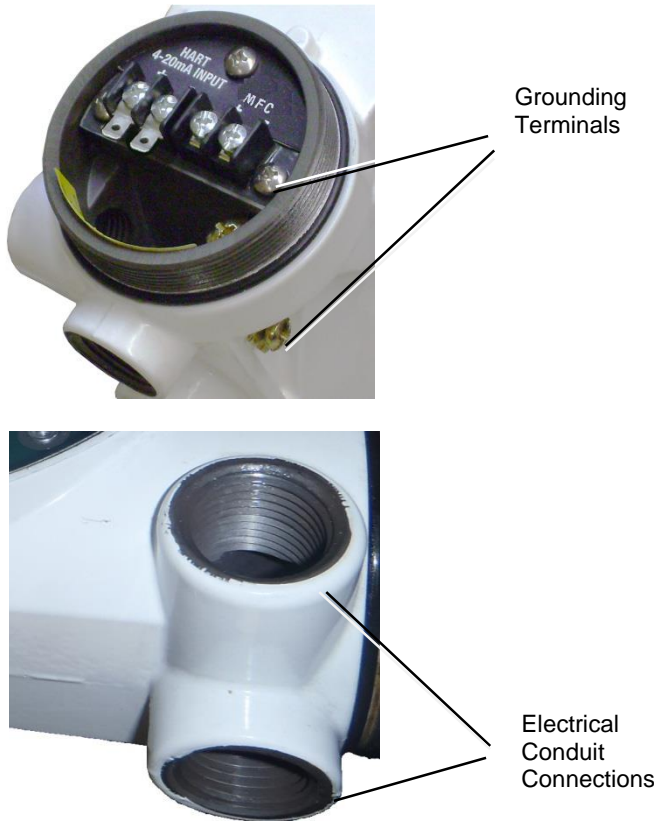

Figure 20: Conduit and Grounding

prevent the positioner from being used in environments with excessively high EM field strengths (greater than 10 V/m). Portable EM devices such as hand-held two-way radios should not be used within 30 cm of the device.

Ensure proper wiring and shielding techniques of the control lines, and route control lines away from electromagnetic sources that may cause unwanted electrical noise. An electromagnetic line filter can be used to further eliminate noise (FLOWSERVE Part Number 10156843).

In the event of a severe electrostatic discharge near the positioner, the device should be inspected to ensure correct operability. It may be necessary to recalibrate the Logix® 3200MD+ positioner to restore operation.

20.3 Multi-Function Card (AO, DO, DI)

The Multi-Function Card can act as an Analog Output (AO), a Discrete Output (DO), or a Discrete Input (DI). Connections to the Multi-Function Card are made directly to the card terminals. For detailed information about voltage and current limits, see Table 12: Auxiliary Card Status below.

See Section: 25 MULTI-FUNCTION CARD for more information.

20.3.1 Analog Output

For AO function wire the MFC in series with a 10 to 40 VDC power supply, including a method to determine the current. When configured as an AO, the current will follow the valve position. See Figure 21.

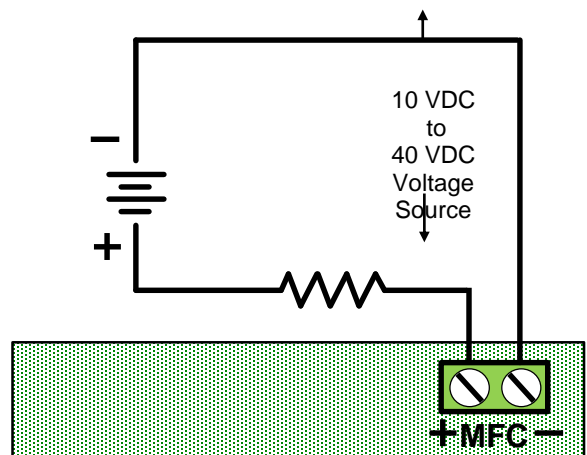

Figure 21: MFC Analog Output Circuit

20.2.5 Electromagnetic Compatibility

The Logix® 3200MD+ digital positioner has been designed to operate correctly in electromagnetic (EM) fields found in typical industrial environments. Care should be taken to

20.3.2 Discrete Output

For DO function, wire the MFC in series with an 8 to 40 VDC power supply, including a method to determine the current such as a resistor. Or use a NAMUR switch amplifier made for this purpose. In DO configuration, the card is a NAMUR switch.

When configured as a DO, current will remain high until the user-defined condition (an alarm) is active, and then drop low when tripped. See Figure 22.

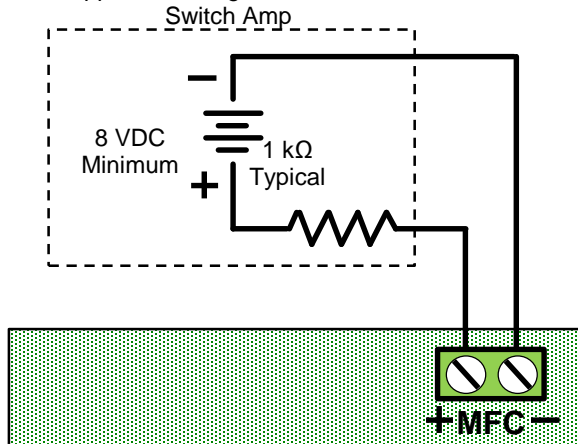

Figure 22: MFC Discrete Output Circuit

20.3.3 Discrete Input

For the DI function, wire the MFC in series with a 0 to 40 VDC power supply. Keep the voltage low under normal circumstances. Raise the voltage to create a tripped input state. See Figure 23.

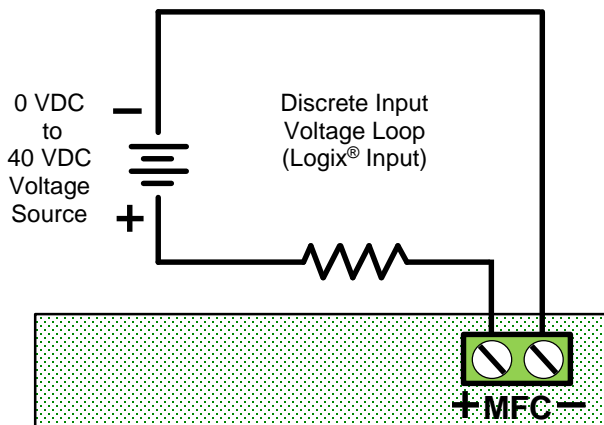

Figure 23: MFC Discrete Input Circuit

Table 12: Auxiliary Card Status		
Card	Condition	Status Indication
Multi-Function Card		
MFC (AO)	Monitoring Position (typical 4-20mA)	Output (mA)
	Less than 8 V on AO terminals.	No Loop Power
MFC (DO)	High output > 2.1 mA (3200MD+ typically 3 mA)	1 - Nominal
	Low 1.2 mA > output > 0.1 mA (typically 0.5 mA)	0 - Tripped
	Less than 0.1 mA	No Loop Power
MFC (DI)	Low (input < 2.5 VDC)	1 - Nominal
	High (input > 8.0 VDC)	0 - Tripped

20.4 Remote Mount

The remote mount option can be used where excessive vibration or environmental factors prevent the placement of a positioner directly on the valve. Wire the remote mount board according to Table 13: Remote Mount Card Connections (See Figure 24). For more information, see Table 6: Remote Mount Specifications on page 12.

Table 13: Remote Mount Card Connections			
From Remote Mount	Terminal (See Error! Reference source not found.)		
	A	B	C
From Remote Mount	Red	White	Black

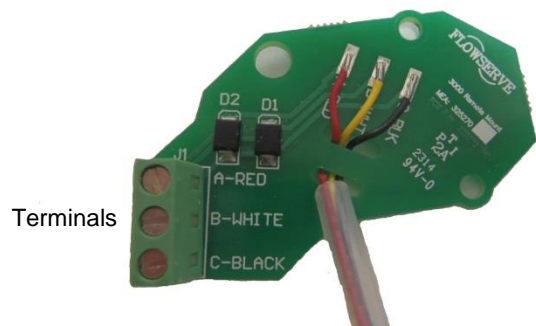

Figure 24: Remote Mount Board

20.5 Connections for Intrinsically Safe Operation

See section 17 HAZARDOUS AREA CERTIFICATIONS for entity parameters and control drawing reference.

21 STARTUP

21.1 Quick Start Instructions

Once the positioner is installed, adjusting the DIP switch settings and performing a Quick-Cal function will typically get the positioner working properly. This simple procedure takes only seconds for most valves.

- Using the Configuration Switches, select the desired configuration.
- Hold the Quick-Cal button for 3 seconds. This will initiate a stroke calibration.

After the stroke calibration is complete, the positioner is ready for control.

CAUTION: During the QUICK-CAL operation the valve may stroke unexpectedly. Notify proper personnel that the valve will stroke, and make sure the valve is properly isolated.

21.2 Local User Interface Overview

The Logix® 3200MD+ local user interface allows the user to calibrate, configure the basic operation, and tune the response of the positioner without additional tools or configurators. See **Error! Reference source not found.**

- Configuration Switches (8) – Used to set basic configuration. See explanations in section 0
- Configuration Switch **Settings**.
- Interface Buttons – Used to calibrate the positioner, perform special functions and navigate the display menu.
 - ▶ QUICK-CAL / ACCEPT
 - ▲ Up
 - ▼ Down
 - ◀ Back
- Selectable GAIN Switch (Rotary) – Used to manually fine-tune the performance.
- LED Indicators (Red, Yellow, and Green) – Indicate status, alarms and warnings.

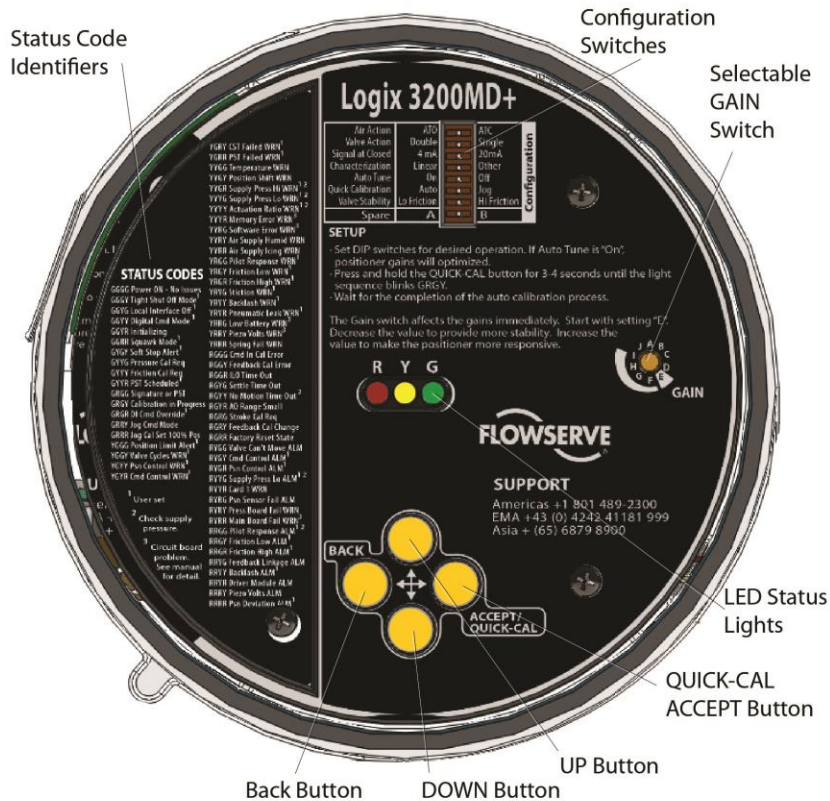

Figure 25: Local User Interface

21.3 Configuration Switch Settings

Before placing the unit in service, set the Configuration Switches to the desired control options.

NOTE: The Configuration Switch settings are activated only by performing a Stroke calibration (pressing the “QUICK-CAL” button for 3 seconds). However, the Configuration Switch settings may be edited from the DTM or Handheld at any time.

21.3.1 Air Action Switch

This must be set to match the configuration of the valve/actuator mechanical tubing connection since the tubing determines the air action of the system.

ATO - Increasing pressure from Port 1 causes the valve to open.

ATC - Increasing pressure from Port 2 causes the valve to close.

21.3.2 Valve Action Switch

This must be set to match the configuration of the actuator and is used in some diagnostics.

Double - Select Double when both sides of the actuator are pressurized.

Single - Select Single when only one side of the actuator is pressurized.

21.3.3 Signal at Closed Switch

Normally this will be set to 4 mA for an Air-To-Open actuator configuration, and 20 mA for Air-To-Close.

4 mA - Selecting 4 mA will make the valve close when the signal is low (4 mA) and open when the signal is high (20 mA).

20 mA - Selecting 20 mA will make the valve close when the signal is high (20 mA) and open when the signal is low (4 mA).

NOTE: When using an Analog Output (AO) function of the Multi-Function Card, the AO signal corresponds with the Signal at Closed selection. If the valve closes with a 4 mA signal, the AO will show a 4 mA signal at closed. If the valve closes with a 20 mA signal, the AO will show a 20 mA signal at closed.

21.3.4 Characterization Switch

The Characterization Switch allows a better match between the input command and the actual fluid flow through the valve. This feature is typically used with valves that have non-linear flow characteristics. The positioner makes a correction by applying an adjustment to the input command according to a characterization curve.

Linear - Select Linear if the actuator position should be directly proportional to the command input signal. (For most rotary valves, this setting gives an =% Cv characteristic due to their inherent =% characteristics.)

Other - Select Other if one of the pre-set characterization curves or a custom curve is desired. The default will be the Custom curve which is populated with a standard 30:1 equal percent rangeability curve which generally opens less than the input command (See Figure 26). To select one of the other curve options, use a Handheld or the ValveSight® DTM. To modify the Custom curve, use the DTM.

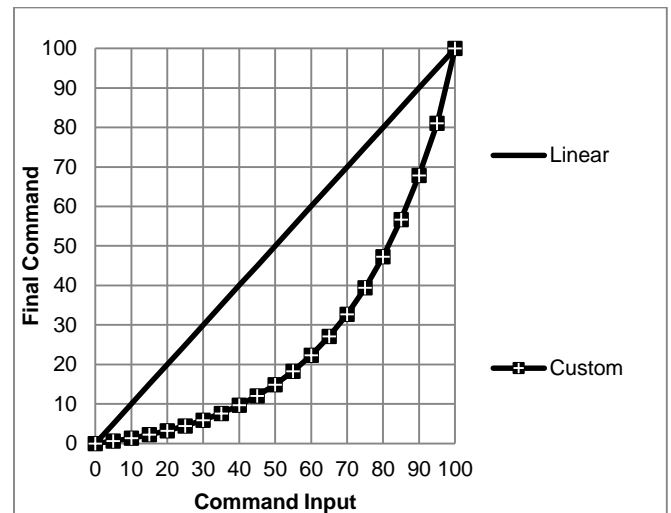

Figure 26: Characterization Curves

21.3.5 Auto Tune Switch

This switch controls whether the positioner will automatically tune itself during the stroke calibration (Quick-Cal), or use preset tuning parameters.

On - Selecting On enables an auto tune feature that will automatically determine the positioner gain settings. The automatic tuning will be based on response parameters measured during the latest Quick-Cal. The valve response is a combination of these response parameters and the current position of the Selectable GAIN Switch.

Off - Selecting Off forces the positioner to use one of the factory preset tuning sets determined by the Selectable GAIN Switch. Settings “B” through “J” are progressively higher predefined tuning sets.

Selecting “A” on the Selectable Gain Switch during a Quick-Cal allows the user to use and preserve manually adjusted gains. See section 21.4 Stroke Calibration for more details.

NOTE: The gain switch is live meaning that regardless of the Auto Tune selection, the gain settings can be adjusted at any time during operation by changing the selectable GAIN switch position. See Figure 27.



Figure 27: Selectable Gain Switch

21.3.6 Quick Calibration Switch

This switch selects between Auto and Jog calibration modes.

Auto - Use the Auto setting if the fully opened position of the valve has a mechanical stop. This is typical for most valves. In Auto mode during a stroke calibration (Quick-Cal), the positioner will fully close the valve and register the 0% position, then fully open the valve to register the 100% position.

Jog - Use the Jog setting if the fully opened position of the valve has no hard stop, but needs to be set manually. In Jog mode during a stroke calibration (Quick-Cal), the positioner will fully close the valve and register the 0% position, then wait for the user to move the valve to the 100% open position using the ▲Up and ▼Down buttons. Press the ►ACCEPT/QUICK-CAL button to accept the 100% location.

See section 21.4 Stroke Calibration for more details.

21.3.7 Valve Stability Switch

This switch adjusts the position control algorithm of the positioner for use with low-friction control valves or high-friction automated valves.

Lo Friction - Placing the switch to Lo Friction optimizes the response for low friction, high performance control valves. This setting provides for optimum response times when used with most low friction control valves.

Hi Friction - Placing the switch to the right optimizes the response for valves and actuators with high friction levels. This setting slightly slows the response and will normally stop limit cycling that can occur on high friction valves.

NOTE: This option is more effective with Advanced or Pro diagnostic levels.

21.3.8 Spare Switch

If special features have been purchased they may be controlled by this switch. See associated documentation for more details.

21.4 Stroke Calibration

The ►ACCEPT/QUICK-CAL button is used to initiate an automatic stroke calibration. The stroke calibration determines the closed (0%) and open (100%) positions of the valve and gathers information about the response of the valve (such as valve stroke time) in order to determine the gains. The gains are then set automatically. After a stroke calibration, the positioner is ready to control.

To perform a Quick-Cal, first ensure the Quick Calibration Switch is set to Auto or Jog as appropriate. Press and hold the ►ACCEPT/QUICK-CAL button for approximately 3 seconds. This will initiate the automatic stroke calibration. While the calibration is in progress, the LED lights will flash status codes indicating the calibration progress. See section 0

Status Code **Descriptions** for an explanation of the status code sequences.

The initial calibration of extremely large or very small actuators may require several calibration attempts. The positioner adapts to the actuator performance and begins each calibration where the last attempt ended. On an initial installation it is recommended that after the first successful calibration that one more calibration be completed for optimum performance.

21.4.1 Quick Calibration Switch – Jog

Set the Quick Calibration Switch to Jog if the valve/actuator assembly has **no** internal mechanical stop at the fully open position. In this case, follow these instructions:

- 1 Press and hold the ►ACCEPT/QUICK-CAL button for approximately 3 seconds.

This will initiate the jog stroke calibration. The positioner will then close the valve and set the zero position. The zero position is automatically always set at the valve seat. At this point the LED's will flash in a sequence of G-R-R-R (green-red-red-red) which indicates that the user must use the jog keys to manually position the valve to approximately 100%.

- 2 Use the up and down keys to position the valve at approximately 100% open.
- 3 Press the ►ACCEPT/QUICK-CAL button to proceed.

No more user actions are required while the calibration process is completed. When the lights return to a sequence that starts with a green light the calibration is complete.

The jog calibration process will only allow the user to set the span. If an elevated zero is needed a handheld or ValveSight® DTM are required.

21.4.2 Tuning Options

Quick-Cal Custom Gains - This is typically the fastest way to achieve ideal gains. Set the Auto Tune Configuration Switch to On and the Selectable GAIN Switch to “E”. Then perform a Quick-Cal. During the Quick-Cal, custom tuning parameters will be determined based on measured response parameters. The gains can then be fine-tuned by adjusting the Selectable GAIN Switch. Selecting “D” “C” or “B” will progressively provide a more stable response. Selecting “F” through “J” will progressively provide a more active response. In most cases selecting “E” will give the best results. This is the default setting for all actuator sizes. Raising or lowering the Selectable GAIN Switch setting is a function of the positioner/valve response to the control signal, and is not actuator size dependent.

Standard Preset Gains - If standard, preset gains are desired, set the Auto Tune Configuration Switch to Off. After performing a Quick-Cal, use the Selectable GAIN switch to the desired level (“B” – “J”). The standard, preset gain settings are not affected by Quick-Cal.

It may be necessary to set the gain switch BEFORE the Quick Cal. Very fast stroking valves may need to be at lower gains and very slow stroking valves may need to be at higher gains.

Custom Manual Gains - To set gains manually, set the selectable GAIN switch to “A”. Changing the switch from “B” to “A” will write the standard “B” settings into the “A” parameters, allowing a starting point for modification. Similarly, changing the switch from “J” to “A” will write the standard “J” settings into the “A” parameters. Custom tuning values can then be entered using the Display Menu, a Handheld or ValveSight® DTM. With the Selectable GAIN Switch set to “A”, the tuning will not be modified during a Quick-Cal.

21.4.3 Aborting a Quick-Cal

The Quick-Cal can be aborted at any time by briefly pressing the ◀ BACK button. In this case, the previous settings will be retained.

21.4.4 On Line Stroke Calibration Adjustments

At times an adjustment to the calibration is desired, but the process cannot be interrupted. The stroke calibration can be adjusted with minimal valve movement. Contact your local Field Service Technician for more information.

21.5 Analog Output (AO) Calibration

The Analog Output (position feedback) function of the Multi-Function Card can be configured calibrated using the DTM or LCD. Ensure the card is installed, the positioner recognizes the card, and it is configured to be an AO.

The DTM AO calibration wizard is found here: Configuration / Card Slot 1 (or 2) / Multi-Function Card / Analog Output Calibration.

22 POSITIONER FUNCTIONS

The following features can be performed using the local interface. Additional features are offered with the use of a Handheld or DTM.

⚠ **NOTE:** *In order to prevent unintentional adjustments of the configuration, tuning, or control of the valve, the Tamper Lock feature may be used. This is set in the DTM and disables the buttons and menus except for the ability to view the status of the positioner. The positioner can be unlocked from the DTM.*

22.1 Live Manual Tuning (Adjusting the Gain)

Use the Selectable GAIN Switch to adjust the gain at any time during operation. This adjustment takes effect immediately. For faster response select settings above “E” (F-J). For more stable response, select settings below “E” (B-D). See **Error! Reference source not found.**

22.2 Local Control Of Valve Position

To manually adjust the position of the valve regardless of the input command (analog or digital), press and hold the ▲Up, ▼Down and ◀ BACK buttons for about 3 seconds. The ▲Up, ▼Down buttons can then be used to position the valve. While in this mode the LED’s will flash a GRRY (green-red-red-yellow) sequence. To exit the local control mode and return to normal operation, briefly press the ▶ ACCEPT/QUICK-CAL button.

⚠ **CAUTION:** *When operating using local control of the valve, the valve will not respond to external commands. Notify proper personnel that the valve will not respond to remote command changes, and make sure the valve is properly isolated.*

22.3 Command Source Reset

Performing a command source reset will reset the command source to analog if it has been inadvertently left in digital mode. This is done while holding down both the ▲Up and ▼Down buttons, and briefly pressing the ▶ ACCEPT/QUICK-CAL button.

22.4 Factory Reset

To perform a factory reset, hold ► ACCEPT/QUICK-CAL button while applying power. All of the internal variables including calibration will be reset to factory defaults. The positioner must be re-calibrated after a factory reset. Tag names and other user configured limits, alarm settings, and valve information will also be lost and need to be restored. A factory reset will always reset the command source to analog 4-20 mA.

➤ **NOTE:** Once the Multi-Function Card (MFC) type has been configured, the type selection will still remain after a factory reset.

⚠ **CAUTION:** Performing a factory reset may result in the inability to operate the valve until reconfigured properly. Notify proper personnel that the valve may stroke, and make sure the valve is properly isolated.

22.5 Viewing Version Numbers

The version number of the embedded code may be checked at any time except during a calibration. To see the major version number, hold the ▲Up button. This will not alter the operation of the unit other than to change the blink sequence to 3 blinks indicating the major version number. Holding the ▼Down button will give the minor version number without affecting operation. The version codes are interpreted according to the following table:

Table 14: Viewing Version Numbers			
First Blink Color	Second Blink Color	Third Blink Color	Version Number
G	G	G	0
G	G	Y	1
G	G	R	2
G	Y	G	3
G	Y	Y	4
G	Y	R	5
G	R	G	6
G	R	Y	7
G	R	R	8
Y	G	G	9
Y	G	Y	10
Y	G	R	11
Y	Y	G	12
Y	Y	Y	13
Y	Y	R	14
Y	R	G	15
Y	R	Y	16
Y	R	R	17
R	G	G	18
R	G	Y	19
R	G	R	20
R	Y	G	21
R	Y	Y	22
R	Y	R	23
R	R	G	24

R	R	Y	25
R	R	R	26

For example, if holding the ▲Up button gave a G-G-R code, and holding the ▼Down gave a Y-Y-G code then the resulting version number would be 2.12.

22.6 Analog Input Calibration

The Analog Input Calibration allows the user to define the mA current that will designate the 0% and 100% commands. This is done by holding down both the ◀ BACK and the ►ACCEPT/QUICK-CAL button for about 3 seconds. The blink code should change to GRYG. Adjust the input current to correspond with the 0% position (usually 4 mA). Briefly press the ►ACCEPT/QUICK-CAL button. The blink code should change to GRYY. Adjust the input current to correspond with the 100% position (usually 20 mA). Briefly press the ►ACCEPT/QUICK-CAL button.

22.7 Select and Calibrate Analog Output

To change the Multi-Function Card to the Analog Output function and calibrate, hold down both the ◀ BACK and the ▲Up button for about 3 seconds. The blink code should change to GYRG. If desired, adjust the output current for the 0% position by pressing the ▲Up or ▼Down button. Briefly press the ►ACCEPT/QUICK-CAL button. The blink code should change to GYRY. If desired, adjust the output current for the 100% position by pressing the ▲Up or ▼Down button. Briefly press the ►ACCEPT/QUICK-CAL button.

22.8 Select Discrete Output

The Discrete Output mode generates a high current of about 7 mA in the normal state. When the Position Deviation alarm is tripped, the output changes to 0.5 mA.

To change the Multi-Function Card to the Discrete Output function, hold down both the ◀ BACK and the ▼Down button for about 3 seconds. The blink code should change to GRYY. Briefly press the ►ACCEPT/QUICK-CAL button.

23 HART COMMUNICATION

The Logix® 3200MD+ series positioners use the HART communication protocol specified by the HART Communication Foundation.

23.1 ValveSight® DTM

Flowserve Corporation has produced a custom Device Type Manager (DTM) for the Logix® 3200MD+ digital positioners to support the ValveSight® diagnostics platform.

The DTM contains a high level “Dashboard” view of the system health and status information. See **Error! Reference source not found.** 28. It also contains comprehensive user-friendly interfaces for control and reporting of alarms, of-line and on-line diagnostic tests, calibrations and system configurations.

The ValveSight® DTM is available from a Flowserve representative or from www.valvesight.com.

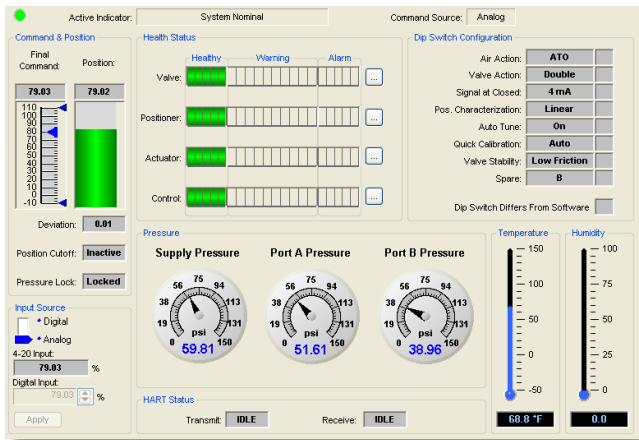

Figure 28: ValveSight DTM Dashboard

23.2 HART 375/475 Handheld Communicator

The Logix® 3200MD+ digital positioner supports and is supported by the HART 375/475 Handheld Communicator. The Device Description (DD) files can be obtained from the HART Communication Foundation or from your Flowserve representative.

23.3 Changing HART Versions

The Logix® 3200MD+ positioner comes standard with the HART 6 communication protocol. Follow this procedure to change to HART 7.

- 1 Remove the outer cover.
- 2 Remove the inner cover by removing the 3 inner cover retaining screws.

CAUTION: Observe precautions for handling electrostatically sensitive devices.

- 3 With a clean, non-conductive instrument, change the position of DIP switch according to **Error! Reference source not found.** After changing the DIP switch, the positioner will immediately recognize the new HART communication protocol.
- 4 Replace the covers.



HART DIP Switch

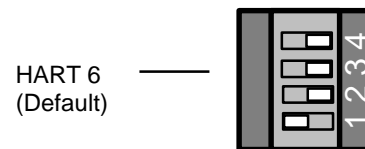

Figure 29: HART DIP Switch

23.4 Burst Mode

Burst Mode is available with a handheld device. In the handheld, select the Burst Mode feature under the Configuration Menu. Variables that are transmitted in burst mode are shown in the table below.

Table 15: Default HART Parameters for Burst Mode

HART Variable	Data Description
Primary	4-20 Command (%)
Secondary	Final Command (%)
Tertiary	Purchased with Standard Diagnostics: Temperature (C) Purchased with Advanced or Pro Diagnostics: Supply Pressure (bar)
Quaternary	Valve Position (%)

↻ **NOTE:** *These variable assignments are reestablished during a factory reset. A field upgrade will not change the tertiary variable.*

↻ **NOTE:** *The DTM will not function while the positioner is in Burst Mode.*

24 MODEL FEATURES

The Logix® 3200MD+ digital positioner includes –

- The QUICK-CAL feature that allows the positioner to be calibrated at the push of one button.
- Limited diagnostics that monitor position, the pilot relay and electronics.
- An 8-DIP configuration switch for flexible set-up.
- A 10-position gain selector switch is also included for quick adjustments to responsiveness.
- An LCD option provides a dashboard for viewing current status and a complete menu for viewing and configuring detailed settings.
- One auxiliary card for analog output (AO), discrete input (DI) and discrete output (DO) functions.
- HART communication.
- A DTM for viewing and controlling advanced features.
- Additional diagnostics depending on the diagnostic level chosen.

24.1 MD+ Positioner Diagnostic Levels

The Logix® 3200MD+ digital positioners have three levels of diagnostics, “Standard”, “Advanced”, and “Pro”.

- “**Standard**” diagnostics provide complete safety and position-related diagnostics and data.
- “**Advanced**” diagnostics provide additional pressure data.
- “**Pro**” diagnostics enhance the off-line tests with additional force data, and provide powerful on-line monitoring capabilities including friction, data logging functions, and comprehensive system health information.

24.2 Valvesight® DTM Diagnostic Levels

The DTM is not required for the positioner to function, but the graphical capabilities of the DTM allow for a richer interface and additional functionality, including viewing the dashboard, charts, annunciator panel, test comparisons, and data logs and printing reports.

The DTM also comes in two versions: “Basic” and “Advanced”.

- The “**Basic**” DTM provides an intuitive, easy-to-use user interface to the positioner. It includes calibration, configuration, auxiliary card information and off-line diagnostic tests. A dashboard gives a quick view of important information.
- The “**Advanced**” DTM provides a view of the positioner’s full health analysis and interfaces to all of the positioner’s “Pro” diagnostic functionality.

It is generally wise to use the Advanced DTM with the Advanced and Pro positioners.

	DTM		Positioner		
	ValveSight® Basic	ValveSight® Advanced	Logix® 3200MD+ (Standard)	Logix® 3221MD+ (Advanced)	Logix® 3222MD+ (Pro)
Quick Calibration Button			X	X	X
3-LED Indicator			X	X	X
8-DIP Configuration			X	X	X
10-Position Gain Adjustment Switch			X	X	X
Multi-Functional Card (AO, DO, DI options)			X	X	X
Remote Mount Option			X	X	X
Humidity Sensor			X	X	X
Terminal Voltage < 10.0 V			X	X	X
HART Communication	X	X	X	X	X
Off-Line Diagnostics (Ramp Test, Step Test, HDRL, Partial Stroke Test)	X	X	X	X	X
On-Line Data Monitor (Monitor and Save Sensor Data)	X	X	X	X	X
Time Stamped Alarms	X	X	X	X	X
Pressure Sensor Data (Supply, Port A, Port B)		X		X	X
On-Line Pro Diagnostics (Force, Actuation, Pneumatic Leak, Continuous Stroke Testing, etc.)		X			X
Health Evaluation (Valve, Positioner, Actuator and Control)		X			X
Training (Determines Typical Behavior)		X			X
Data Logging (High Speed Internal Data Capture)		X			X
Long-Term Trend Logging (14 parameters over 15 years)		X			X

25 MULTI-FUNCTION CARD

The optional Multi-Function Card (MFC) can be configured to act as an Analog Output, Discrete Output, or Discrete Input.

MFCs are immune to RFI/EMI disturbances. See certifications in section 17.

Table 17: Multi-Function Card Cross References		
Information	IOM Section	Page
Analog Output Specifications	16.4 Analog Output	11
Electronic Connections	20.3 Multi-Function Card (AO, DO, DI)	25
Status	Table 12: Auxiliary Card Status	26
Certifications	17 Hazardous Area Certifications	13

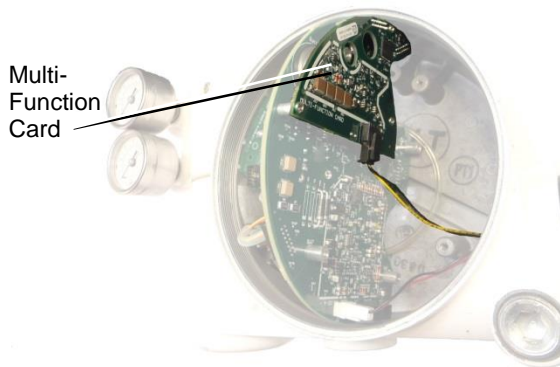

Figure 30: Multi-Function Card

25.1 Analog Output (AO)

Configure the MFC as an Analog Output device to produce a 4-20 mA signal that corresponds to the position of the valve.

Output follows actual position of valve, including all failure modes of positioner except loss of power. An output of < 1.0 mA is transmitted when the positioner loses power.

Calibration of the analog output signal is performed using the display menu, a HART handheld communicator, or the ValveSight® DTM or push-buttons. To change the Multi-Function Card to the Analog Output function and calibrate using the buttons, see section 22.7.

The MFC configured as an AO does not interfere with positioner operation.

NOTE: The AO signal corresponds with the Signal At Closed configuration switch setting. If the valve closes with a 4 mA signal, the AO will show a 4 mA signal when closed. If the valve closes with a 20 mA signal, the AO will show a 20 mA signal when closed.

25.2 Discrete Output (DO)

Use the Discrete Output function of the MFC to indicate a variety of conditions such as alarms, warnings, position limits, etc. Alarms that are masked will not cause the DO to trip. The current is normally high, and drops low when one of the pre-configured states occurs.

Configuration of the discrete output signal is done using the ValveSight® DTM or push-buttons. To change the Multi-Function Card to the Discrete Output function using the buttons, see section 22.7.

The MFC configured as a DO does not interfere with positioner operation.

The MFC DO complies with DIN 19234 standard. For specific current limits, see Table 12: Auxiliary Card Status.

25.3 Discrete Input (DI)

Use the Discrete Input function of the MFC to signal the positioner to begin a partial stroke test, or move to a predefined position as long as the signal remains.

Supply a low voltage (or no voltage) to indicate a normal state. Raise the voltage to indicate the tripped state.

Configuration of the discrete output signal is done using the display menu, a HART handheld Communicator, or the ValveSight® DTM.

For specific voltage limits, see Table 12: Auxiliary Card Status.

CAUTION: During the use of the Discrete Input function, the valve may stroke unexpectedly. Follow internal procedures, ensuring that the configured movement of the valve (performing a PST or moving to a set-point) is allowed. Notify proper personnel that the valve will stroke, and make sure the valve is properly isolated if required.

26 REMOTE MOUNT

26.1 Remote Mount Operation

The remote mount option can be used where excessive vibration or environmental factors prevent the placement of a positioner directly on the valve.

The remote mount unit consists of just the feedback mechanism enclosed in a sturdy container. This assembly is mounted to the valve/actuator assembly. The actuator tubing and feedback signals are routed some distance to the positioner. Tubing is connected to the positioner. The feedback signal wires are connected to a remote mount board installed in the Logix® 3200MD+ positioner. See Figure 31.

Table 18: Remote Mount Cross-References			
Information		Section	Page
Electronic Specifications	16.6	Remote Mount Specifications	12
Electronic Connections	20.4	Remote Mount	26
Ordering a Remote Mount Board	31.2	Spare Parts Kits	56
Ordering a Remote Mount Device	30.1	Positioner Dimensions	53

For more information on the remote mount option, see Logix® Remote Mount Option user instructions, FCD LGENIM0001.

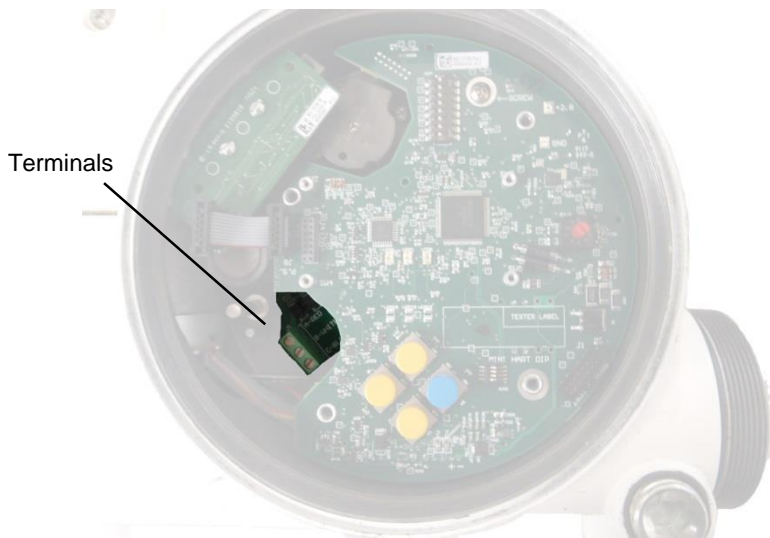

Figure 31: Remote Mount Terminals

27 Positioner Maintenance

The kits listed in section 31.2 Spare Parts Kits can be replaced by a technician trained in positioner function and handling of static sensitive devices.

CAUTION: *Depressurize the positioner before servicing.*

CAUTION: *Use eye protection.*

CAUTION: *When touching the circuit boards, observe precautions for handling electrostatically sensitive devices.*

27.1 Scheduled Maintenance

The supply gas filter(s) should be scheduled for regular maintenance as required to maintain supply gas quality. If contamination is found in the filter, the inside of the positioner should be visually inspected for contamination. If contamination is found in the positioner, the positioner should be replaced.

27.2 Required Tools and Equipment

The Logix® 3200MD+ digital positioner has modular components that can be replaced using the tools shown in

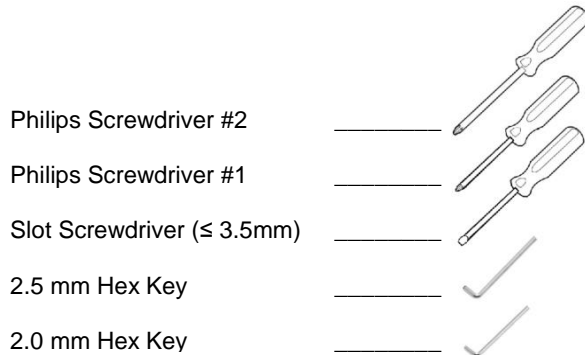

Figure 32: Tools for Positioner Maintenance

The spool, block and manifold of the double acting relay can be cleaned using acetone, a soft cotton cloth and cotton swabs.

27.3 Torque Requirements for Screws

Component	Torque
Inner Cover (3 Screws)	0.34 N-m (3 in-lb)
Main Board (1 Screw)	0.34 N-m (3 in-lb)
Pressure Board (4 Screws)	0.68 N-m (6 in-lb)
Double Acting Relay Block (2 Screws)	0.56 N-m (5 in-lb)
Double Acting Relay manifold (2 Screws)	0.56 N-m (5 in-lb)
User Interface terminal connections.	0.5 – 0.6 N-m (4-5 in-lb)

27.4 Replacing the Multi-Function Card

Removal

- 1 Make sure the valve is bypassed or in a safe condition.
- 2 Disconnect the power to the positioner.
- 3 Remove the main cover.
- 4 Remove the plastic inner cover by removing the three screws (See Figure 34).
- 5 Unplug the pressure sensor connector from the main board (See Figure 37).
- 6 Remove main board screw and auxiliary board screw (See Figure 35).
- 7 Gently lift the main board out of the housing.
- 8 Unplug the auxiliary card connector from the board (See Figure 30).
- 9 Unplug the auxiliary card from the back of the main board.

Installation

- 1 Plug the auxiliary card into the connector in the back of the main board (See Figure 30).
- 2 Plug the auxiliary card connector into the back of the auxiliary (See Figure 30)
- 3 Place the main board back into the housing. Make sure Piezo Cable, Hall Sensor Cable, Feedback Pot and Pressure Sensor cable are placed below the lower mounting boss as shown in Figure 33.
- 4 Reinstall the main board screw and auxiliary card screw.
- 5 Plug the pressure sensor connector into the main board (See Figure 37).
- 6 Reinstall the plastic inner cover and reinstall the three screws (See Figure 34).

CAUTION: *Ensure proper circuitry is used before connecting cables to the auxiliary card. See section 20 ELECTRICAL CONNECTIONS for more information.*

- 7 Reinstall the main cover.

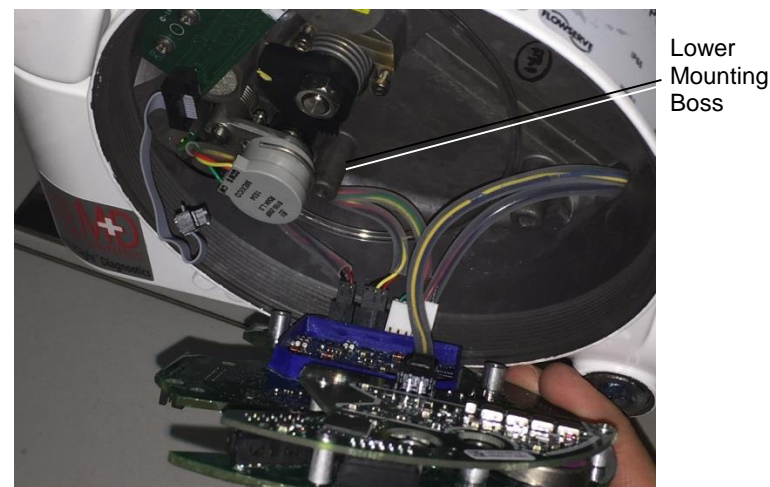

Figure 33: Cable Placement

27.5 Replacing a Main Board

Removal

- 1 Make sure the valve is bypassed or in a safe condition.
- 2 Disconnect the power and air to the positioner.
- 3 Remove the outer cover.
- 4 Remove the inner cover. See Figure 34: Inner Cover below.
- 5 Disconnect the power cable to the main board.
- 6 Disconnect the auxiliary card cable if present. See Figure 30.
- 7 Remove the inner cover by removing the 3 retaining screws. See Figure 34.
- 8 Unplug the pressure sensor board connector from the main board. See Figure 37.
- 9 Remove the screw from the main circuit board. See Figure 35.
- 10 Gently lift the main board rotating the top up while keeping the bottom in place.

Disconnect the hall sensor cable, the piezo cable, current source cable and the feedback pot cable. (Use a small flat screwdriver to pry the locking features and carefully separate the connector from the main board. Be careful not to pull the cable, as this may cause damage to the cable.) See Figure 36.

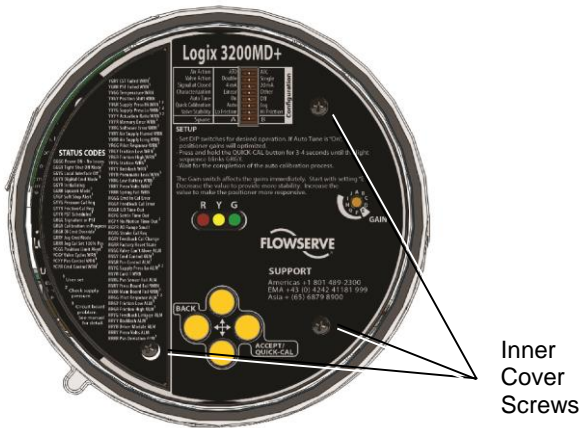

Figure 35: Inner Cover

Installation

- 1 Place the main board over the positioner base.
- 2 Lift the main board rotating the top upwards while keeping the bottom in place.
- 3 Plug in the hall sensor cable, the piezo cable, current source cable and the feedback pot cable into the main board. Ensure the connectors' locking features engage.
- 4 Place the main board on the positioner base.
- 5 Connect the pressure sensor board cable on to the main board.
- 6 Reinstall the main board screw.
- 7 Replace the inner cover by reinstalling the 3 retaining screws.
- 8 Reconnect power.

- 9 Calibrate.



Figure 36: Main Board Screw

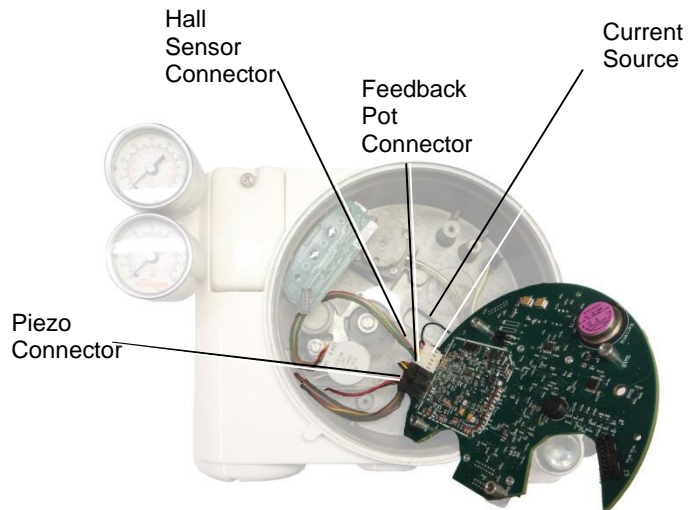

Figure 34: Main Board Connectors

27.6 Replacing the Pressure Sensor Board

Removal

- 1 Make sure valve is bypassed or in a safe condition.
- 2 Disconnect power and air to the positioner.
- 3 Remove plastic inner cover.
- 4 Unplug pressure sensor from the main board.
- 5 Unscrew the 4 screws holding the pressure sensor board in place. See **Error! Reference source not found.**37.
- 6 Remove the pressure sensor board.

Installation

- 1 Place the pressure sensor O-rings in the three holes.
- 2 Cover the O-rings with the pressure sensor board.
- 3 Insert the 4 screws. Tighten until the pressure sensor board makes firm contact with the base.
- 4 Plug the pressure sensor cable back into the main board.
- 5 Reinstall the plastic inner cover.

Calibration

- 1 Initiate a Pressure or Triple Calibration from the DTM.

- 2 To calibrate the supply pressure sensor 0 value, disconnect the supply air. Go to Edit Variables. Write the value from variable 74 (PS ADC Count) to variable 71. (PS ADC Count at 0 psi). Reconnect the supply air.
- 3 To keep the calibration values even after a Factory Reset, write a 1 to Variable 104.

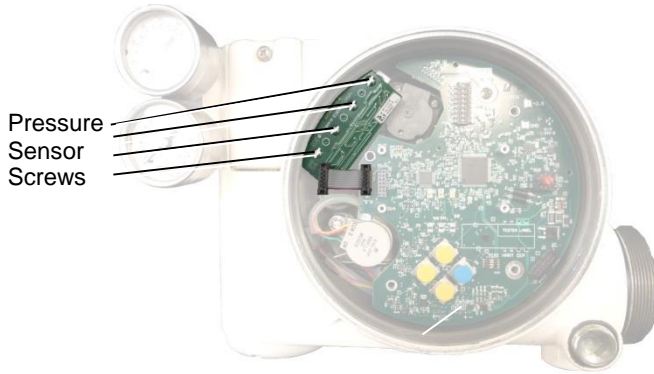

Figure 37: Pressure Sensor Board

27.7 Replacing and Cleaning a Spool Valve

The spool valve routes the supply air to one side of the actuator while venting the opposite side (See Figure 2). The position of the spool valve is controlled by the driver module.

Removal

- 1 Remove the spool valve cover by removing the screw and sliding the cover assembly backwards until the tab is clear of the slot. The sheet metal cap, hydrophobic filter, and O-ring should be removed with the spool valve cover. It is not necessary to take these parts out of the spool valve cover. See Figure 38.
- 2 Being careful not to lose the nylon washer, remove the Phillips-head screw that attaches the driver module to the main housing. See Figure 39.

CAUTION: *Spool (extending from the driver module assembly) is easily damaged. Use extreme caution when handling spool and spool valve block. Do not handle the spool by the machined portions of spool. The tolerances between the block and spool are extremely tight. Contamination in the block or the spool may cause the spool to hang.*

- 3 Remove the spool valve block by removing the two Phillips-head screws and carefully sliding the block off the spool. See Figure 39.
- 4 Carefully remove the spool by sliding the end of the spool out of the connection clip. Excessive force may bend spool.

Cleaning

- 1 Using acetone and a cotton cloth wipe down the block and manifold.
- 2 Use cotton swabs to reach inside air passage ways.
- 3 Dry components thoroughly.

CAUTION: *Follow precautions on acetone label and MSDS.*

Installation

- 1 Verify that the three O-rings are in the counterbores on the machined platform where the spool valve block is to be placed. (Figure 42).
- 2 Carefully slide the spool into the connecting clip on the top of the driver module assembly.
- 3 Carefully slide the block over the spool, using the machined surface of the house base as a register. (Figure 39). Slide the block toward the driver module until the two retaining holes line up with the threaded holes in the base.
- 4 Install the two spool-valve screws and tighten securely with a Phillips screwdriver (See Figure 39).
- 5 Slide the spool valve cover assembly over the spool valve until the tang engages in the housing slot. Install spool valve cover screw and tighten securely (See Figure 38).

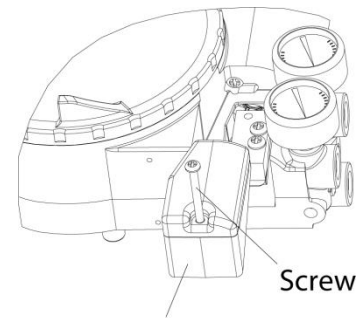

Spool Valve Cover

Figure 38: Spool Valve Cover Assembly

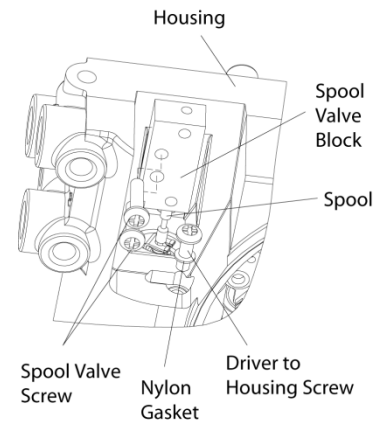

Figure 39: Spool and Block

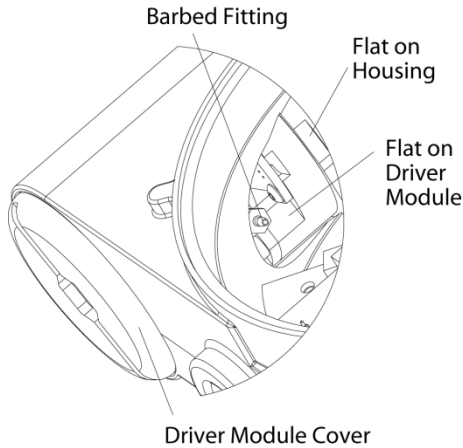

Figure 40: Driver Module Barbed Fitting

27.8 Replacing a Driver Module Assembly

The driver module assembly moves the spool valve by means of a differential pressure across its diaphragm. Air routed to the driver module from the regulator through a flexible hose. A barbed fitting connects the flexible hose to the driver module assembly. Wires from the driver module assembly connect the Hall Effect sensor and the piezo valve modulator to the main PCB assembly.

Removal

- 1 Remove the driver module cover (Figure 40), using a flat bar or plate in the slot to turn the cover.
- 2 Remove the spool valve cover by removing the screw and sliding the cover assembly backwards until the tab is clear of the slot (Figure 38). The sheet metal cap, hydrophobic filter, and O-ring should be removed with the spool valve cover. It is not necessary to take these parts out of the spool valve cover.
- 3 Being careful not to lose the nylon washer, remove the Phillips-head screw that attaches the driver module to the main housing (Figure 39).

CAUTION: Spool (extending from the driver module assembly) is easily damaged. Use extreme caution when handling spool and spool valve block. Do not handle the spool by the machined portions of spool. The tolerances between the block and spool are extremely tight. Contamination in the block or the spool may cause the spool to hang.

- 4 Remove the spool valve block by removing the two Phillips-head screws and carefully sliding the block off the spool (Figure 39).
- 5 Carefully remove the spool by sliding the end of the spool out of the connection clip. Excessive force may bend spool.
- 6 Remove the main cover.
- 7 Remove the plastic board cover by removing the three retaining screws.
- 8 Disconnect the flexible tubing from the barbed fitting at the driver.

- 9 Use the ¼" nutdriver to remove the barbed fitting from the driver module assembly.
- 10 Unplug the two wiring connections that link the driver module assembly to the main PCB assembly.
- 11 Feed the two wires on the driver module back into the driver module compartment so that they stick out the driver module opening (See Figure 41). This will allow the driver module to thread out without tangling or cutting wires.
- 12 Grasp the base of the driver module and turn it counterclockwise to remove. After it is threaded out, carefully retract the driver module from the housing.
- 13 Remove the barbed fitting from the side of the driver module as shown in Figure 41 and hold the wires in position by hand.

Installation

- 1 Verify that the O-ring is in place on the top of the new driver module. Lay the wires back along the side of the driver module as shown in Figure 41 and hold the wires in position by hand.
- 2 Gently insert the driver module into the driver module compartment in the housing. Turn the driver module clockwise to thread it into the housing. Continue rotating the driver module until it bottoms out.
- 3 Once the driver module has bottomed out so that the threads are fully engaged, rotate the driver module counter clockwise until the flow on the driver module and the flat on the house are aligned. This will align the screw hole for the next step.
- 4 Verify that the nylon gasket is in the counter bore in the driver module retaining screw hole as shown in Figure 39.
- 5 Insert a driver-to-housing screw into the driver housing through the counter bored hole in positioner main housing. Tighten with a Phillip screwdriver.
- 6 Reach through the main compartment in the driver module compartment of the positioner and install the barbed fitting on the side of the driver module using the ¼" nutdriver.

NOTE: Do not mix the barbed fitting with those from older Logix® positioners. Older models contain orifices that will not work in the Logix® 3200MD+ model. Orifices are brass-colored, barbed fittings are silver-colored.

- 7 Reconnect the flexible tube coming from the regulator to the barbed fitting.
- 8 Feed the driver module wires into the main chamber of the housing and connect them to the main PCB Assembly.
- 9 Verify that the three O-rings are in the counterbores on the machined platform where the spool valve block is to be placed. (Figure 42).
- 10 Carefully slide the spool into the connecting clip on the top of the driver module assembly.
- 11 Carefully slide the block over the spool, using the machined surface of the house base as a register. (Figure 39). Slide the block toward the driver module until the two retaining holes line up with the threaded holes in the base.
- 12 Install the two spool-valve screws and tighten securely with a Phillips screwdriver (See Figure 39).

- 13 Slide the spool valve cover assembly over the spool valve until the tang engages in the housing slot. Install spool valve cover screw and tighten securely (See Figure 38).
- 14 Install the plastic board cover. Insert the three retaining screw through the plastic cover into the threaded boss and tighten evenly, using a Phillips screwdriver. Do not over tighten.
- 15 Reconnect power and air supply to the positioner and perform a stroke calibration.
- 16 Reinstall all covers.

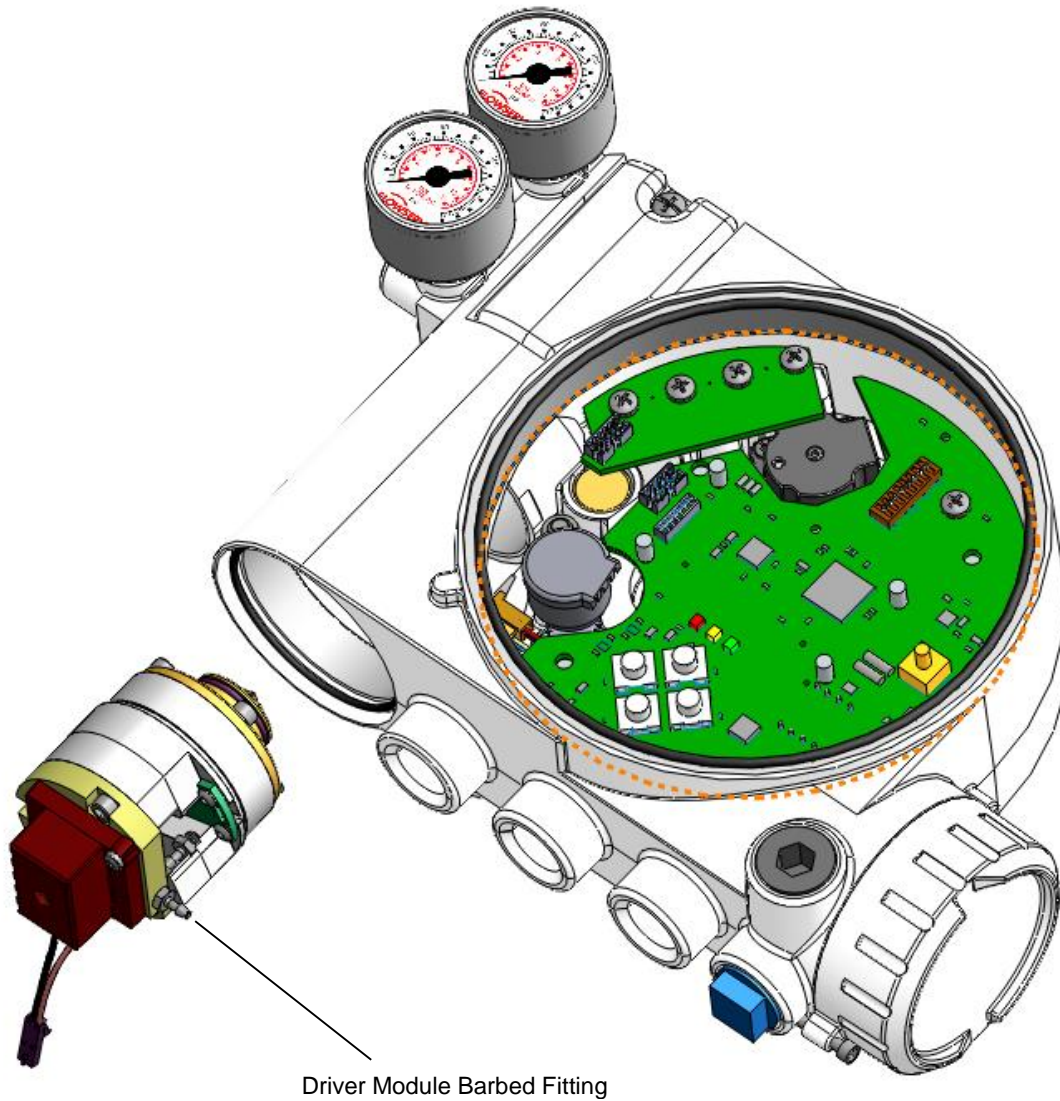

Figure 41: Driver Module Barbed Fitting

28 TROUBLESHOOTING

28.1 Troubleshooting Guide

Table 20: Troubleshooting Guide		
Failure	Probable Cause	Corrective action
No LED is blinking.	<ol style="list-style-type: none"> 1. Current source too low. 2. Voltage of current source is too low. 3. Incorrect wiring polarity. 	<ol style="list-style-type: none"> 1. Verify current source supplies at least 3,8 mA. 2. Verify voltage source supplies at least 10VDC. 3. Check wiring for correct polarity.
Erratic communications.	<ol style="list-style-type: none"> 1. Current source bandwidth not limited to 25Hz. 2. Maximum cable length or cable impedance exceeded. 3. HART modem connected to PC RS-232 port not receiving enough power 4. Interference with I.S. barrier. 5. Current source stripping (filtering) HART signal. 	<ol style="list-style-type: none"> 1. Maximum allowable current source rate of change is 924 mA per second. 2. Check cable size, length and capacitance. See Section 20 ELECTRICAL CONNECTIONS. 3. Verify laptop battery is not low. 4. Must use HART compatible I.S. barrier. 5. Use a 250Ω resistor and a 22 μF capacitor to create a HART filter according to the following schematic.
Unit does not respond to analog commands.	<ol style="list-style-type: none"> 1. The positioner is in digital command mode. 2. An error occurred during calibration. 	<ol style="list-style-type: none"> 1. Switch to analog command mode using the procedure outlined in Section 22.3 Command Source Reset, use the ValveSight® DTM, or use a handheld communicator. 2. <u>Check Status Codes. Correct calibration</u>
Valve position reading is not what is expected.	<ol style="list-style-type: none"> 1. Stem position sensor mounting is off 180 degrees. 2. Stroke not calibrated 3. Tight shutoff MPC (Minimum position cutoff) is active. 4. Custom characterization or soft stops are active. 	<ol style="list-style-type: none"> 1. Reposition the sensor. 2. Perform a Stroke calibration (Quick-Cal). 3. Verify Tight Shutoff settings. 4. Verify custom characterization or soft-stop limits.
Position is driven fully open or closed and will not respond to command.	<ol style="list-style-type: none"> 1. Stroke is not calibrated. 2. Inner-loop hall sensor is not connected. 3. Wrong air action was entered in software. 4. Actuator tubing is backward. 5. Electro-pneumatic converter is malfunctioning. 6. Control parameter inner-loop offset is too high/low. 	<ol style="list-style-type: none"> 1. Perform stroke calibration (Quick-Cal) 2. Verify hardware connections. 3. Check ATO (Air-to-open) and ATC (Air-to-Close) settings. Recalibrate using Quick-Cal to apply settings. 4. Verify ATO/ATC actuator tubing. 5. Replace electro-pneumatic converter. 6. Adjust inner-loop and see if proper control resumes.
Sticking or hunting operation of the positioner	<ol style="list-style-type: none"> 1. Contamination of the electro-pneumatic converter. 2. Control tuning parameters not correct. 3. Packing friction is high. 4. Spool valve is corroded or dirty. 	<ol style="list-style-type: none"> 1. Check air supply for proper filtering and meeting ISA specifications ISA-7.0.01. 2. Lower proportional gain settings. 3. Enable the stability DIP switch on the local interface and recalibrate. If problem persists, adjust pressure control window with handheld communicator or ValveSight® and recalibrate. 4. Disassemble and clean spool valve.

28.2 Status Code Index

NOTE: Not all status codes are available with all positioner models.

Table 21: Status Code Index	
Description	Status Code
A/O Cal in Prog	GRGY
A/O Range Small	RGYR
Actuation Ratio WRN	YYYY
Actuator Cycles WRN	YGGY
Actuator Travel WRN	YGGY
Air Supply Humid WRN	YYRY
Air Supply Icing WRN	YYRR
Analog In < ADC Range	RGGG
Analog In > ADC Range	RGGG
Analog In Cal Error	RGGG
Analog In Cal in Prog	GRGY
Analog In Range Small	RGGG
Backlash ALM	RRYY
Backlash WRN	YRYR
Bellows Cycles WRN	YGGY
Bellows Travel WRN	YGGY
Calibration in Progress	GRGY
Card 1 Error	RYYR
Card 1 Fail WRN	RYYR
Card 1 No Loop Pwr	RYYR
Card 1 WRN	RYYR
Closed Too Far WRN	YGYR
Cmd Amplitude ALM	RYGY
Cmd Amplitude WRN	YGYR
Cmd Control ALM	RYGY
Cmd Control WRN	YGYR
Cmd Frequency ALM	RYGY
Cmd Frequency WRN	YGYR
CST Failed WRN	YGRY

DI Cmd Override	GRGR
Digital Cmd Mode	GGYY
Driver Module ALM	RRYR
Factory Reset State	RGRR
Feedback Cal Change	RGRY
Feedback Cal Error	RGGY
Feedback Linkage ALM	RRYG
Friction Cal in Prog	GRGY
Friction Cal Req	GYYY
Friction High ALM	RRGR
Friction High WRN	YRGR
Friction Low ALM	RRGY
Friction Low WRN	YRGY
ILO Time Out	RGGR
Initializing	GGYR
Jog Cal Set 100% Pos	GRRR
Jog Cmd Mode	GRRY
Local Interface Off	GGYG
Low Battery WRN	YRRG
Main Board Fail WRN	RYRR
Memory Error WRN	YYYY
No Motion Time Out	RGYY
Opened Too Far WRN	YGYR
Piezo Volts ALM	RRRY
Piezo Volts High ALM	RRRY
Piezo Volts High WRN	YRRY
Piezo Volts Low ALM	RRRY
Piezo Volts Low WRN	YRRY
Piezo Volts WRN	YRRY
Pilot Cycles WRN	YGGY
Pilot Response ALM	RRGG
Pilot Response WRN	YRGG
Pilot Travel WRN	YGGY

Pneumatic Leak WRN	YRYR
Position < ADC Range	RGGY
Position > ADC Range	RGGY
Position Limit Alert	YGGG
Position Range Small	RGGY
Position Shift WRN	YGYR
Power ON	GGGG
Press Board Fail WRN	RYRY
Pressure Cal in Prog	GRGY
Pressure Cal Req	GYYG
Psn Amplitude ALM	RYGR
Psn Amplitude WRN	YGYR
Psn Control ALM	RYGR
Psn Control WRN	YGYR
Psn Deviation ALM	RRRR
Psn Frequency ALM	RYGR
Psn Frequency WRN	YGYR
Psn High Limit Alert	YGGG
Psn Low Limit Alert	YGGG
Psn Sensor Fail ALM	RYRG
PST Failed WRN	YGRR
PST Scheduled	GGYR
Setting ILO	GRGY
Settle Time Out	RGYR
Signature or PST	GRGG
Soft Stop Alert	YGYR
Soft Stop High Alert	YGYR
Soft Stop Low Alert	YGYR
Software Error WRN	YYRG
Spring Fail WRN	YRRR
Squawk Mode	GGRR
Stroke Cal in Prog	GRGY
Stroke Cal Req	RGRG

Stroke Shift	RGRY
Stroke Span Decrease	RGRY
Stroke Span Increase	RGRY
Supply Press Hi WRN	YYGR
Supply Press Lo ALM	RYYG
Supply Press Lo WRN	YYYG
Temperature High WRN	YYGG
Temperature Low WRN	YYGG
Temperature WRN	YYGG
Tight Shut Off Mode	GGGY
Valve Can't Move ALM	RYGG
Valve Can't Open ALM	RYGG
Valve Can't Shut ALM	RYGG
Valve Cycles WRN	YGGY
Valve Travel WRN	YGGY

28.3 Status Code Descriptions

➤ **NOTE:** *Not all status codes are available with all positioner models.*

GGGG 
POWER ON

Description: No issues.

Possible Solutions: Not applicable.

GGGY 
TIGHT SHUT OFF MODE

Description: (Also called MPC.) The Final Command is beyond the user set limit for the tight shutoff feature and the positioner is applying full actuator pressure to close (or open) the valve. This is a normal condition for all valves when closed. The factory default setting triggers this at command signals below 1%. This indication may also occur on 3 way valves at both ends of travel if the upper Tight Shut Off value has been set.

Possible Solutions: If tight shutoff is not desired reset the tight shutoff limits or adjust the command signal inside of the specified Tight Shut Off values.

GGYG 
LOCAL INTERFACE OFF

Description: Control and configuration features are locked at the positioner's local interface. This is to prevent unauthorized or accidental adjustments. The buttons can still be used to view information on the LCD. The status code is only present for a short time when the user attempts to make a change through the display menu.

Possible Solutions: The DTM's Local Interface page is used to unlock the local interface, turn this feature on and off, and to set the PIN. For temporary access, a Personal Identification Number (PIN) can be entered from the positioner if an LCD is installed.

GGYY 
DIGITAL COMMAND MODE

Description: The input command is set by a digital HART command instead of the 4-20 mA signal.

Possible Solutions: The input command source can be changed back to the 4-20 mA signal by using a handheld, the Dashboard page of the DTM, or performing a manual Command Reset. Perform the Command Reset by holding both the UP and DOWN buttons and briefly pressing the QUICK-CAL/ACCEPT button.

GGYR 
INITIALIZING

Description: The positioner has powered up and is displaying a blink sequence 3 times.

Possible Solutions: Wait for 3 blink sequences to complete.

GGRR 
SQUAWK MODE

Description: A user has set the positioner to flash a special sequence so that it can be visually located.

Possible Solutions: This mode is cancelled if one of the following occurs: 1) The QUICK-CAL/ACCEPT button is briefly pressed. 2) The Squawk mode is turned off remotely. 3) More than one hour has passed since the command was issued.

GYGY 
SOFT STOP HIGH LIMIT ALERT
SOFT STOP LOW LIMIT ALERT

Description: The Final Command would move the valve beyond the user-set Soft Limit, but the internal software is holding the position at the limit. The function is similar to a mechanical limit stop except it is not active if the unit is unpowered.

Possible Solutions: If more travel is needed, reset the Soft Limits. If not, adjust the Final Command signal back into the specified range.

GYYG 
PRESSURE CALIBRATION REQUIRED

Description: A Factory Pressure Calibration has not been performed. Unlike a regular pressure sensor calibration, a Factory Pressure Calibration saves the calibration values to memory, making them available should a factory reset be performed. Proper pressure sensor calibration is required for proper pressure sensing and diagnostics. Calibration values from a regular pressure sensor calibration will be lost when a factory reset is performed. Typically no pressure calibration is required with a new positioner.

Possible Solutions: After replacing a main board or a pressure sensor board, perform a Factory Pressure Calibration. To do this, see the Pressure Sensor Board Removal and Installation section of the IOM.

GYYY 
FRICTION CALIBRATION REQUIRED

Description: No friction calibration has been performed since the last factory reset. The friction calibration determines a preliminary friction value, spring forces and

direction and other information used for proper diagnostics. If no friction calibration is performed, the positioner will soon determine the operating friction, but other diagnostic information will be missing.

Possible Solutions: Perform a Friction Calibration using the display menu, handheld, or Sensor Calibration page of the DTM. See the Calibration section of the IOM for warnings.

GYR

PARTIAL STROKE TEST SCHEDULED

Description: The schedule established by the user shows that a partial stroke test is due.

Possible Solutions: Follow internal procedures to initiate a partial stroke test (PST). A partial stroke test will cause the valve to move suddenly and the positioner will not respond to commands while the PST is in progress. See the Partial Stroke Test page of the DTM to verify PST settings.

GRGG

SIGNATURE OR PARTIAL STROKE TEST IN PROGRESS

Description: The positioner is in Out Of Service (OOS) mode because a test or signature has been initiated. These include Step Test, Ramp Test, or Partial Stroke Test.

Possible Solutions: Signatures and tests can be defined, initiated, and cancelled through the Off-Line Diagnostics pages of the DTM.

GRGY

STROKE CALIBRATION IN PROGRESS SETTING INNER LOOP OFFSET PRESSURE CALIBRATION IN PROGRESS FRICTION CALIBRATION IN PROGRESS ANALOG OUTPUT CALIBRATION IN PROGRESS COMMAND INPUT CALIBRATION IN PROGRESS

Description: A calibration sequence is in progress. The inner loop offset is an important step of the stroke calibration.

Possible Solutions: The calibration can be canceled from the corresponding calibration page of the DTM, from the handheld, or by briefly pressing the BACK button.

GRGR

DI COMMAND OVERRIDE

Description: The Multi-Function Card has been configured as a Discrete Input (DI) and to override the input command, positioning the valve at a preconfigured set point. The DI signal is active and the positioner is attempting to control the valve at the set point.

Possible Solutions: Configure the DI function and set point using the menu, a handheld or the Multi-Function Card Configuration page of the DTM.

GRRY

JOG COMMAND MODE

Description: The positioner has been placed in a local override mode where the valve can only be stroked using the UP and DOWN buttons. The positioner will not respond to analog or digital input commands from HART.

Possible Solutions: Control the valve using the UP and DOWN buttons. This mode may be cancelled by briefly pushing the QUICK-CAL/ACCEPT button.

GRRR

JOG CALIBRATION SET 100% POSITION

Description: During a jog calibration, the unit is waiting for the user to manually adjust the valve position to the desired 100% open position.

Possible Solutions: Use the Up and Down buttons on the positioner to adjust the valve to the desired fully open position. The QUICK-CAL/ACCEPT button to accept.

YGGG

POSITION HIGH LIMIT ALERT POSITION LOW LIMIT ALERT

Description: The position has reached or is exceeding a user defined position limit. This is similar to a limit switch indicator.

Possible Solutions: Set the limit to a higher (or lower) value if more travel is needed, or adjust the command signal back in the specified range.

YGGY

ACTUATOR CYCLES WARNING ACTUATOR TRAVEL WARNING BELLOWS CYCLES WARNING BELLOWS TRAVEL WARNING PILOT RELAY CYCLES WARNING PILOT RELAY TRAVEL WARNING VALVE CYCLES WARNING VALVE TRAVEL WARNING

Description: The cycle or travel limit of the valve, actuator, bellows or pilot relay has been exceeded. Each cycle represents two reversals of the direction of valve movement. The cycle counting criterion and count limit (for the valve, actuator and bellows) are set by the user to track the usage of the valve assembly.

Possible Solutions: Follow routine procedures for maintenance when the limit is reached. For example valve inspection may include checking the packing tightness, and

checking linkages for wear, misalignment, and tightness. Bellows inspection may include checking bellows for cracking or leaking. Actuator inspection may include checking the actuator seals and lubrication. Relay inspection may include checking for high air consumption and signs of wear on the spool. After maintenance, reset the travel accumulator.

YGY Y ● ● ● ●

POSITION AMPLITUDE WARNING POSITION FREQUENCY WARNING

Description: The amplitude or frequency of the position signal is above the warning limit. The positioner is controlling the position of the valve with large or rapid corrections.

Possible Solutions: Verify the limits are set at an appropriate level. Adjust the selectable Gain switch to a lower setting or use the Hi Friction setting. Perform a QUICK-CAL which sets the gains based on valve response. Check for high friction. If the problem persists replace the relay.

YGYR ● ● ● ●

COMMAND AMPLITUDE WARNING COMMAND FREQUENCY WARNING

Description: The amplitude or frequency of the command signal is above the warning limit. This could mean the control loop has larger swings or is oscillating faster than desirable.

Possible Solutions: Verify the limits are set at an appropriate level. Review the control loop parameters and equipment. Adjust as necessary.

YGRY ● ● ● ●

CONTINUOUS STROKE TEST FAILED WARNING

Description: During the continuous stroke test, the valve did not move after 5 consecutive attempts. This could mean the valve has increased friction, a change in process load or inadequate supply pressure.

Possible Solutions: Check friction, supply pressure and other alarms or warnings that would indicate difficulty in moving the valve. Check packing, and air supply. The warning will clear when the CST function is turned off or when a successful attempt to move the valve occurs.

YGRR ● ● ● ●

PARTIAL STROKE TEST FAILED WARNING

Description: Measured times or forces during the last partial stroke test did not pass the criteria set by the user. This may be an indication of corrosion build-up on the valve stem or in the actuator, low or restricted supply pressure, or a sticking positioner relay.

Possible Solutions: This warning will clear upon completion of a successful partial stroke test.

YYGG ● ● ● ●

TEMPERATURE HIGH WARNING TEMPERATURE LOW WARNING

Description: The temperature of the internal electronics has exceeded the manufacturer set limits of -40°C (-40°F) to 85°C (176°F). Low temperature may inhibit responsiveness and accuracy. High temperature may affect performance or limit the life of the positioner.

Possible Solutions: Regulate the temperature of the positioner by shading or cooling supply gas. Heat the positioner if needed. If the temperature reading is in error, replace the main board.

YYGY ● ● ● ●

VALVE CLOSED TOO FAR WARNING VALVE OPENED TOO FAR WARNING

Description: While the valve was in use, it closed or opened farther than it did at the last calibration by 0.5%.

Possible Solutions: Check the feedback arm linkage and ensure the valve stem connection is tight. Recalibrate the stroke. If the process cannot be interrupted a service technician may be able to adjust the calibration.

YYGR ● ● ● ●

SUPPLY PRESSURE HIGH WARNING

Description: The supply pressure is above the user set warning limit. Supply pressure that exceeds the maximum rating on the actuator can become a potential hazard.

Possible Solutions: Regulate the supply pressure at the positioner below the maximum limit recommended for your actuator. Recalibrate pressure sensors. Check the pressure sensor board connections. Replace pressure sensor board if necessary.

YYYG ● ● ● ●

SUPPLY PRESSURE LOW WARNING

Description: The supply pressure is below the user set warning limit. Low supply pressure can cause poor valve response or positioner failure. The minimum recommended supply pressure for proper operation is 1.3 bar (19 PSI).

Possible Solutions: Regulate the supply pressure at the positioner above 1.3 bar (19 PSI). Ensure system air/gas supply is adequate. Repair kinked or restricted supply tubing. Check for pneumatic leaks in the actuator and actuator tubing. Recalibrate pressure sensors. Check the pressure sensor board connections and replace pressure sensor board if necessary.

YYYY

ACTUATION RATIO WARNING

Description: The force required to control the system is close to the maximum available force. Actuation Ratio is based on the ratio of available force to the required force to fully actuate. Control may be lost if this ratio reaches 100%. It is affected by the process load, friction, spring force, and available supply pressure.

Possible Solutions: Increase the supply pressure. Reduce the friction. Check the actuator spring. Resize the actuator. Adjust user set limits.

YYR

MEMORY ERROR WARNING

Description: The microprocessor's memory has a problem.

Possible Solutions: Error may clear with time. If error persists, cycle power and complete a QUICK-CAL. If the error still persists, perform a factory reset, reprogram or replace the main circuit board.

YYRG

SOFTWARE ERROR WARNING

Description: There has been a watch dog time out, stack overflow warning, or CPU usage warning.

Possible Solutions: If the problem persists, perform a factory reset. If it still persists, reprogram or replace the main board.

YYRY

AIR SUPPLY HUMID WARNING

Description: The supply gas has high relative humidity which can lead to condensation on electronic components and failure of electronic functions.

Possible Solutions: Ensure supply gas is clean and dry. Check and clean the regulator filter.

YYRR

AIR SUPPLY ICING WARNING AIR SUPPLY ICING WARNING

Description: The supply gas has high relative humidity and the temperature is close to 0 °C (32 °F). Under these conditions ice may form in the pilot relay causing diminished or total loss of position control.

Possible Solutions: Ensure supply gas is clean and dry. Check and clean the regulator filter.

YRGG

PILOT RELAY RESPONSE WARNING

Description: The pilot relay is sticking or slow to respond. This affects the responsiveness, increases the chance of limit cycling and excessive air consumption. The pilot relay is part of the inner loop and consists of the driver module assembly with piezo (I-P relay) which is coupled to the spool valve. The value of this indicator corresponds with inner loop lag. Delayed response can be caused by a partially clogged piezo or debris, oil, corrosion, or ice on the spool, or low supply pressure.

Possible Solutions: Check response of the valve. If OK, adjust Pilot Relay Response limits. Check supply pressure. Check the spool for debris, oil, corrosion, ice on the spool. Clean or replace the spool assembly. Replace the piezo or driver module assembly. Maintain a clean, water-free air/gas supply.

YRGY

FRICION LOW WARNING

Description: The friction has passed below the user set limit. Low friction is an indication of improperly loaded packing and, in severe cases, can be an indication of the process fluid leaking at the valve stem.

Possible Solutions: Check for packing leak. Tighten or replace the valve packing.

YRGR

FRICION HIGH WARNING

Description: The valve and actuator friction has passed the user set limit. High friction can cause loop oscillations, poor position control, jerky motion, or valve sticking. It can be caused by build-up from the process on the stem, trim or seat, by a failing bearing or guides in the valve and actuator, galling of the trim or stem, excessively tightened packing, linkages, or other valve or actuator mechanical issues.

Possible Solutions: Determine if the friction is significantly interfering with the valve control. If not, consider increasing the friction warning limit. Consider the following to reduce friction: Stroke the valve to clear off build-up. Clear any external mechanical obstruction, loosen the packing, clean the stem, repair or replace the actuator. Highly localized friction or very jerky travel can indicate internal galling. Repair or replace internal valve components.

YRY

BACKLASH WARNING

Description: The amount of detected backlash has passed the user set warning limit. This may affect valve stability.

Possible Solutions: Check the stem and actuator for loose components.

YRYR ●●●●
PNEUMATIC LEAK WARNING

Description: The positioner has detected a leak in the actuation assembly. Leakage from the actuator can cause decreased responsiveness and excessive air/gas consumption.

Possible Solutions: Repair pneumatic leaks at the tubing junctions and actuator seals. Check spool valve for excessive wear.

YRRG ●●●●
LOW BATTERY WARNING

Description: The battery for the real time clock is low. The battery is designed for a 15+ year life with the positioner unpowered. The battery is not required for the positioner to control properly, but is used only to maintain the time and date upon loss of power. The time and date affect the time stamps of alarms, warnings and other events. This warning could be caused by rapidly power cycling the positioner.

Possible Solutions: The battery is not replaceable. Verify or reset the time and date. Replace the main board if the problem persists for several days.

YRRY ●●●●
PIEZO VOLTAGE HIGH WARNING
PIEZO VOLTAGE LOW WARNING

Description: If the voltage to the piezo is too high, this could indicate an error with the relay or the main board. This may result from an extended period of inactivity, but in this case should not persist for more than 30 minutes when the valve is controlling. The positioner may still be functioning, but have reduced performance under some circumstances. If the voltage to the piezo is too low, the piezo may be damaged. This may prevent the proper failure position upon loss of signal/power. This condition may occur briefly on an air-to-close valve that is held for long periods of time in the closed position, or an air-to-open valve held in the open position.

Possible Solutions: Ensure the supply pressure is not low. If alarm persists for more than 30 minutes, the Piezo assembly is damaged. Replace the pilot relay.

YRRR ●●●●
SPRING UNABLE TO FAIL SAFE WARNING

Description: Upon loss of air supply, the valve may not move to the fail-safe position. The spring alone is not adequate to overcome the friction and process load in the system. The system is relying on pneumatic force to

actuate in the direction the spring is pushing. The failsafe spring may have failed, or it was not sized properly for the application. Friction or process load may have increased.

Possible Solutions: Repair or replace actuator spring. Check for high friction. Reduce process load.

RGGG ●●●●
COMMAND INPUT BELOW ADC RANGE
COMMAND INPUT ABOVE ADC RANGE
COMMAND INPUT RANGE TOO SMALL

Description: During Command Loop Calibration, the signal was out of the Analog to Digital Converter (ADC) range, or difference between the signal at 0% and the signal at 100% was too small. The system is designed to accept a difference greater than 5 mA and between 10 and 4085 ADC.

Possible Solutions: Recalibrate making sure to use valid command signal values.

RGGY ●●●●
POSITION RANGE TOO SMALL
POSITION SENSOR ABOVE ADC RANGE
POSITION SENSOR BELOW ADC RANGE

Description: During calibration, the range of motion of the position feedback arm was too small for optimum performance or the feedback sensor moved beyond its range of operation.

Possible Solutions: Check for loose linkages. Adjust the positioner mounting. Adjust the feedback pin back into range. Adjust the feedback pin to a position closer to the follower arm pivot to create a larger angle of rotation and recalibrate. The minimum angle of rotation should be greater than 15 degrees. Briefly pressing the QUICK-CAL/ACCEPT button acknowledges a small range and the positioner will operate using the short stroke calibration if otherwise a good calibration.

RGGR ●●●●
INNER LOOP OFFSET TIME OUT

Description: During calibration the Inner Loop Offset (ILO) value did not settle. This could result in less accurate positioning.

Possible Solutions: Repeat the stroke calibration to get a more accurate ILO value. To proceed using the less accurate ILO value, this error may be cleared by briefly pushing the QUICK-CAL/ACCEPT button. Lowering the setting on the gain selection switch may help if the actuator is unstable during the calibration.

RGYG

SETTLE TIME OUT

Description: During calibration, the position feedback sensor showed movement, but did not settle.

Possible Solutions: Check for loose linkages or a loose positioner sensor. This error may appear on some very small actuators during the initial calibration. Recalibrating may clear the problem, or this error may be cleared by briefly pushing the QUICK-CAL/ACCEPT button.

RGYY

NO MOTION TIME OUT

Description: During a stroke calibration, there was no valve motion detected. Because some valves are quite large, this indicator can take up to 9 minutes to detect an error.

Possible Solutions: Check linkages and air supply to make sure the system is properly connected. If the time out occurred because the actuator is very large then simply retry the QUICK-CAL and the positioner will automatically adjust for a larger actuator by doubling the time allowed for movement. This error may be cleared by briefly pushing the QUICK-CAL/ACCEPT.

RGYR

ANALOG OUTPUT RANGE TOO SMALL

Description: During an Analog Output Calibration the difference between the milliamp signal at 0% and the milliamp signal at 100% was too small.

Possible Solutions: Recalibrate making sure to use a larger difference between signal limits. This notification can be cleared by briefly pressing the QUICK-CAL/ACCEPT button.

RGRG

STROKE CALIBRATION REQUIRED

Description: A factory reset was performed and the positioner has not yet been calibrated. The unit will not respond to commands and will remain in the failsafe position until a calibration is successfully completed.

Possible Solutions: Perform a Stroke Calibration (QUICK-CAL) by holding the QUICK-CAL/ACCEPT button down for 3 seconds, or perform a Pressure or Friction calibration if desired. See the Calibration section of the IOM for warnings.

RGRY

STROKE SHIFT

Description: The 0% and 100% valve positions have both shifted in the same direction since the last stroke calibration. This may be related to a bent or adjusted

feedback linkage, loose positioner mounting, or an over rotated feedback potentiometer.

STROKE SPAN DECREASE

Description: The 0% and 100% valve positions are closer together compared to the last stroke calibration. This could indicate debris or build up at valve seat.

STROKE SPAN INCREASE

Description: The 0% and 100% valve positions are farther apart compared to the last stroke calibration. This could indicate seat wear.

Possible Solutions: Ensure the feedback linkage is not bent and the positioner is mounted securely. If the feedback potentiometer is over-rotated, repeat the stroke calibration until the Stroke Shift error is no longer present. Inspect valve or schedule valve for inspection. This notification can be cleared by briefly pressing the QUICK-CAL/ACCEPT button.

RGRR

FACTORY RESET STATE

Description: The positioner is in factory reset state. Calibration is required to enable control.

Possible Solutions: Perform a Stroke Calibration (QUICK-CAL).

RYGG

VALVE CAN'T OPEN ALARM
VALVE CAN'T SHUT ALARM

Description: Pressure has been applied (or removed) to open or shut the valve, but the valve is not moving. This may be caused by excessive friction.

Possible Solutions: Verify adequate supply pressure is applied. Verify the feedback linkage is connected. View the friction trends if available. Consider the following: Clear any external or internal mechanical obstruction, loosen the packing, clean the stem, repair or replace the actuator, repair the valve if galling is suspected.

RYGY

COMMAND AMPLITUDE ALARM
COMMAND FREQUENCY ALARM

Description: The amplitude or frequency of the command signal is above the alarm limit. This could mean the control loop has larger or faster swings than desirable.

Possible Solutions: Verify the limits are set at an appropriate level. Review the control loop parameters and equipment. Adjust as necessary.

RYGR

POSITION AMPLITUDE ALARM
POSITION FREQUENCY ALARM

Description: The amplitude or frequency of the position signal is above the alarm limit. The positioner is controlling the position of the valve with large or rapid corrections.

Possible Solutions: Verify the limits are set at an appropriate level. Adjust the selectable Gain switch to a lower setting or use the Hi Friction setting. Perform a QUICK-CAL which sets the gains based on valve response. Check for high friction. If the problem persists replace the relay.

RYYG

SUPPLY PRESSURE LOW ALARM

Description: The supply pressure is below the user set warning limit. Low supply pressure can cause poor valve response or positioner failure. The minimum recommended supply pressure for proper operation is 1.3 bar (19 PSI).

Possible Solutions: Regulate the supply pressure at the positioner above 1.3 bar (19 PSI). Ensure system air/gas supply is adequate. Repair kinked or restricted supply tubing. Check for pneumatic leaks in the actuator and actuator tubing. Recalibrate pressure sensors. Check the pressure sensor board connections and replace pressure sensor board if necessary.

RYYR

AUX CARD 1 ERROR

Description: Auxiliary Card 1 has an electrical problem.

AUX CARD 1 FAILURE WARNING

Description: Auxiliary Card 1 is not communicating.

AUX CARD 1 NO LOOP POWER

Description: Auxiliary Card 1 has no loop current.

Possible Solutions: MFC: Check auxiliary loop wiring and ensure adequate compliance voltage and current. Check auxiliary card connection to the main board. Replace card if condition persists.

RYRG

POSITION SENSOR FAILURE ALARM

Description: The feedback arm may be disconnected from the valve assembly or the sensor has failed.

Possible Solutions: Check the feedback arm linkage. Recalibrate. If the problem persists return the unit for repair.

RYRY

PRESSURE SENSOR BOARD FAILURE WARNING

Description: One or more pressure sensors may have failed.

Possible Solutions: Check the supply pressure to ensure it is between 1.3 and 10.3 bar (19 and 150 PSI). Check the pressure sensor board connections. Recalibrate the pressure sensors. If the problem persists, replace the pressure sensor board.

RYRR

MAIN BOARD ELECTRONIC FAILURE WARNING

Description: There has been an oscillator fault, position sensor ADC failure, supply voltage error, reference voltage error, shunt voltage error, or piezo voltage error.

Possible Solutions: This may be caused by transient conditions. If the error persists, replace the main board.

RRGG

PILOT RELAY RESPONSE ALARM

Description: The pilot relay is sticking or extremely slow to respond. This affects the responsiveness, increases the chance of limit cycling and excessive air consumption. The pilot relay consists of the driver module assembly with piezo (I-P relay) which is coupled to the spool valve. Delayed response can be caused by a partially clogged piezo or debris, oil, corrosion, or ice on the spool, or low supply pressure.

Possible Solutions: Check response of the valve. If OK, adjust Pilot Relay Response limits. Check the supply pressure. Check the spool for debris, oil, corrosion, ice on the spool. Clean or replace the spool assembly. Replace the piezo or driver module assembly. Maintain a clean, water-free air/gas supply.

RRGY

FRICITION LOW ALARM

Description: The friction has passed below the user set limit. Low friction is an indication of improperly loaded packing and, in severe cases, can be an indication of the process fluid leaking at the valve stem.

Possible Solutions: Check for a packing leak. Tighten or replace the valve packing.

RRGR

FRICITION HIGH ALARM

Description: The valve and actuator friction has passed the user set limit. High friction can cause loop oscillations, poor position control, jerky motion, or valve sticking. It can

be caused by build-up from the process on the stem, trim or seat, by a failing bearing or guides in the valve and actuator, galling of the trim or stem, excessively tightened packing, linkages, or other valve or actuator mechanical issues.

Possible Solutions: Determine if the friction is significantly interfering with the valve control. If not, consider increasing the friction warning limit. Consider the following to reduce friction: Stroke the valve to clear off build-up. Clear any external mechanical obstruction, loosen the packing, clean the stem, repair or replace the actuator. Highly localized friction or very jerky travel can indicate internal galling. Repair or replace internal valve components.

RRYG

FEEDBACK LINKAGE ALARM

Description: The feedback linkage is broken or the position feedback POT is out of range.

Possible Solutions: Fix broken linkage or adjust feedback arm until full motion is within the range of the POT.

RRYY

BACKLASH ALARM

Description: The amount of detected backlash has passed the user set alarm limit. This may affect valve stability.

Possible Solutions: Check the stem and actuator for loose components.

RRYR

DRIVER MODULE ALARM

Description: The pilot relay can't open, the pilot relay can't shut, or the Hall sensor circuit has failed.

Possible Solutions: Check the internal wiring connections. Replace the pilot relay.

RRRY

PIEZO VOLTAGE HIGH ALARM

Description: The voltage driving the piezo is above the alarm limit. This could indicate an error with the relay or the main board. The positioner may still be functioning, but have reduced performance under some circumstances.

PIEZO VOLTAGE LOW ALARM

Description: The voltage to the piezo is too low. The piezo may be damaged. This may prevent the proper failure position upon loss of signal/power. This condition may occur briefly on an air-to-close valve that is held for long periods of time in the closed position, or an air-to-open valve held in the open position.

Possible Solutions: Ensure the supply pressure is not low. If alarm persists for more than 30 minutes, the Piezo assembly is damaged. Replace the pilot relay.

RRRR

POSITION DEVIATION ALARM

Description: The difference between the command and the actual position has been greater than the user-set limit for longer than a user-set time.

Possible Solutions: Review active alarms and warnings to find root causes of this alarm. The deviation settings can be changed in the Valve Health page of the DTM.

Metal parts should be scrapped, with the remaining materials disposed of according to national regulations.

28.4 Help From Flowserve

28.4.1 Phone Support

Over-the-phone troubleshooting is often available for positioner issues. Should your positioner be experiencing problems, or if you have questions that are not answered by this manual, feel free to call your local sales representative or a Quick Response Center (QRC). See the back cover of this manual for contact details.

28.4.2 Returning the 3200MD+ Positioner for Service

If troubleshooting is unable to solve the problem, the unit may be returned. Please follow the steps below.

1. Request a Return Goods Authorization (RGA) form. An RGA form will be e-mailed to you to accompany the unit being returned.
2. Remove all fittings, brackets, filters, feedback arms, etc. from the unit before packaging.
3. If the unit was operated with a gas other than clean air, please include the related MSDS with the return.
4. Complete the RGA form. Write any specific issues with the positioner you would like us to evaluate. Please include the customer name and contact information.
5. When packaging, please secure the unit in a method that will insure it will reach our facility undamaged (the weight of positioners will often settle through packing peanuts and pop large air packets).
6. Please insert a copy of the completed RGA form inside the package and write the RGA number on the outside of the package. Send the unit to the address at the bottom of the form.

If the cause of the unit failure is found to be a manufacturing defect and the unit is within the warranty period (18 months from manufacture) it will be repaired free of charge. If no problem is found with the unit and the unit is still under warranty, a fee for the evaluation will be required. If the cause of the unit failure is not covered under the warranty a fee will be charged for the evaluation and a quote will be provided showing the cost of the repair. If the customer decides to purchase a new positioner, the evaluation fee will be waved.

29 Disposal

Electronic components are contained inside the positioner.

NOTICE: Potential hazards and their sources are under the operator's influence. The operator must observe national and international environmental conditions for positioner removal from the valve and cleaning. Permissible limit values must be maintained to ensure suitable protective measures; service personnel must be properly instructed in performing the disassembly and reassembly procedure.

30 POSITIONER DIMENSIONS

30.1 Positioner Dimensions

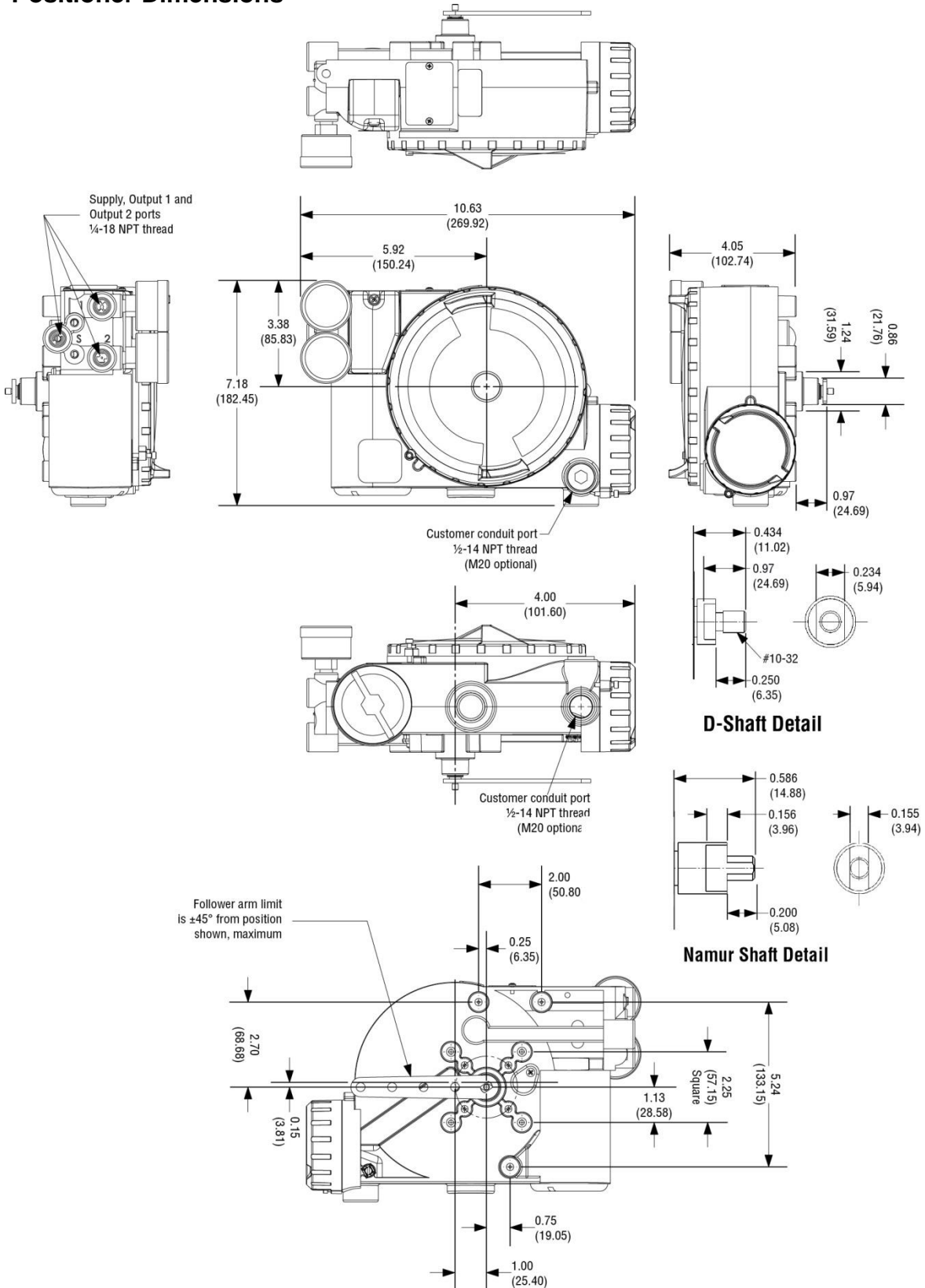

31 HOW TO ORDER

31.1 Positioners

Table 22: 3200MD+ Positioner Configurations				
Selection	Description	Code	Notes	Example
Base Model	Logix 3000+ Series	3		3
Communication	HART	2	1	2
Diagnostics	Standard Diagnostics (Standard Functionality)	00	2	20
	Advanced Diagnostics (With Pressure Sensing)	10	2	
	Pro Diagnostics (With Pressure Sensing and Full ValveSight® Diagnostics)	20		
Design Version		MD+		MD+
Certifications	General Purpose	14		34
	ATEX/IECEX Explosion Proof, Intrinsically Safe, Non-Incendive	28		
	FM/CSA Explosion Proof, Intrinsically Safe, Non-Incendive	34	5	
Positioner Configuration				
Housing	Aluminum, White Paint (Valtek)	W		W
	Aluminum, Black Paint (Automax)	B		
	Aluminum, Black Paint (Accord)	A		
Conduit Connections	1/2" NPT	1		1
	M20	2	5	
Feedback Shaft	DD - 316 Stainless Steel Shaft (Valtek Standard)	V		V
	NAMUR - 316 Stainless Steel Shaft (VDI/VDE 3845)	R		
	D - 316 Stainless Shaft (3rd Party Actuators)	D		
Action	Four-way (Double-Acting)	1		1
	Three-way (Single-Acting)	2		
	Three-way Purge (Single-Acting)	3	3	
	Four-way Vented (Double-Acting)	4		
	Three-way Vented (Single Acting)	5		
Special Options	No Special Options	0		0
Optional Mechanical Add-Ins				
Pressure Gauges	No Gauges	0		1
	SS with Brass Internals, psi (bar/kPa) (Valtek Standard)	1		
	SS with SS Internals, psi (bar/kPa)	2		
	SS with Brass Internals, psi (kg/cm2)	3		
	SS with SS Internals, psi (kg/cm2)	4		
	UCC Press Test Plug, 1/8" NPT	A		
	Valve, Tank, Schrader 645A	B		
Optional Electronic Add-Ins				
Auxiliary Card Slot	No Card	0		1
	Multi-Function Card	1	4	
Remote Mount	No Remote Mount Feedback	0		0
	Aluminum Remote Mount Feedback	A		
	Stainless Steel Remote Mount Feedback	S		

- 1 HART 6 standard. Can be configured as HART 7 in the field.
- 2 Can be upgraded in the field.
- 3 Not for use with natural gas. Used to purge spring side of actuator with instrument air.
- 4 MFC can be configured in the field as Analog Output (position feedback), Discrete Output (Logic feedback) or Discrete Input (position set point or start PST).
- 5 Housings with M20 conduit threads are not available with Certification Code 34

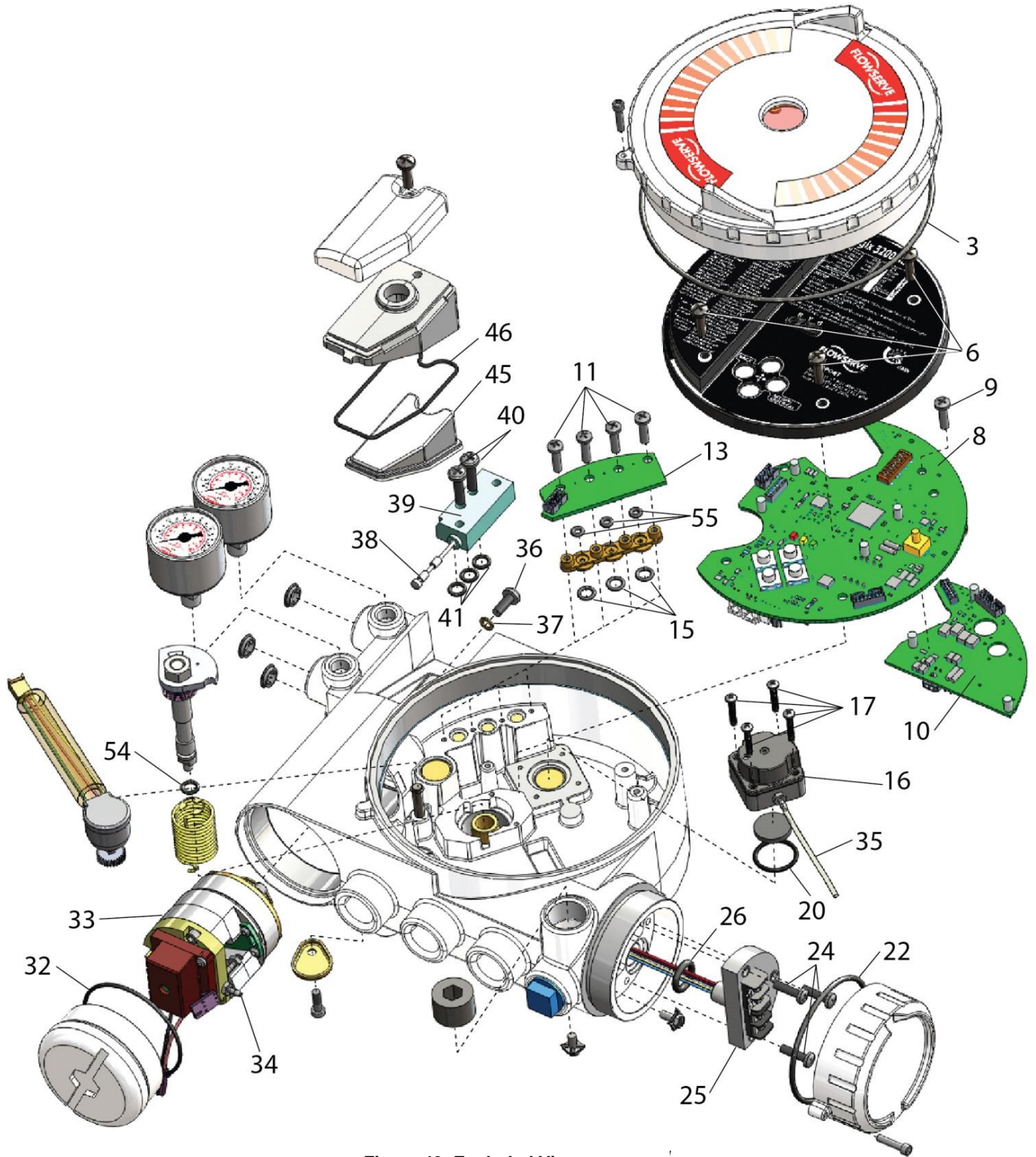

Figure 42: Exploded View

31.2 Spare Parts Kits

Table 23: Spare Parts Kits		
Ref.	Description	Part-no.
Kit 2: Driver Module Assembly, P/N 338691.999.000		
16	Pressure Regulator	1
17	Screw, Regulator to Housing	4
33	Driver Module Assembly	1
34	Hex Barbed Fitting w/ Captive O-ring	1
36	Screw Driver to Housing	1
37	Nylon Washer	1
Kit 3: Spool Assembly Valve Kit, P/N 199787.999.000		
38	Spool	1
39	Spool Valve Block	1
40	Screw, Spool Valve to Housing	2
41	O-ring; Spool Valve	3
Kit 4: Pressure Regulator, P/N 215814.999.000		
16	Pressure Regulator	1
17	Screw, Regulator to Housing	4
Kit 7: Soft Goods Kit, P/N 338692.999.000		
3	O-ring, Main Housing Cover	1
15	O-ring, Pressure Sensor to Manifold	3
20	O-ring, Regulator to Housing	1
22	O-ring, Customer Interface Cover	1
26	O-ring, Customer Interface Board	1
35	Flexible Tube	1
37	Nylon Washer	1
41	O-ring, Spool Valve to Housing	3
45	Hydrophobic Filter, Spool Valve Chamber	1
46	O-ring, Spool Valve Cover	1
54	O-ring, Feedback Shaft	1
55	O-ring, Pressure Sensor Manifold to Housing	3
Kit 8: Pressure Sensor Board Kit, P/N 338693.999.000		
11	Screw, Pressure Sensor Board	4
13	Pressure Sensor Board	1
15	O-ring, Pressure Sensor to Manifold	3
55	O-ring, Pressure Sensor Manifold to Housing	3
Kit 9: Main PCB Assembly Kit, P/N 338694.999.000		
6	Screw, Main PCB Cover Short	2
7	Screw, Main PCB Cover Long	1
8	Main PCB	1
9	Screw Main PCB Retaining Screw	1
Kit 10: User Interface Board Kit, P/N 338695.999.000		
24	Screw, Customer Interface to Housing	3
25	Customer Interface Board	1
26	O-ring, Customer Interface Board	1
Kit 11: Multi-Function Card, P/N 338696.999.000		
10	Multi-Function Card	1
Kit 12: Position Feedback Potentiometer Kit, P/N 338697.999.000		
49	E-ring	1
50	Position Feedback Spring	1
51	Position Feedback Potentiometer	1

➤ **NOTE:** Multi-function cards may be purchased as upgrades and installed after the initial purchase of the positioner. In this case, the positioner label must be modified to reflect the change.

31.3 Mounting Kits

Table 24: Valtek Linear Mounting Kits						
Spud	25 in ²		50 in ²		100-200 in ²	
	Standard	Handwheel	Standard	Handwheel	Standard	Handwheel
2.00	164432	164433	164434*	164433		
2.62			164435	164436	164437**	164436
2.88					164437	164438
3.38					164439	164440
4.75					164439	164440

* A Size 50, 2.00 spud with live-loading requires kit number 339302.999.000

** Live-loading is not available on a Size 100, 2.62 spud

Table 25: Valtek Rotary Mounting Kits						
Shaft Size	25 in ²		50 in ²		100-200 in ²	
	Standard	Optional	Standard	Optional	Standard	Optional
0.44	135429	135432	135430		135431	
0.63	135429	135437	135430	135433	135431	
0.75	135429	135438	135430	137212	135431	
0.88	135429	135439	135430	137213	135431	135434
1.12	135429		135430	137214	135431	137218
1.50	135429		135430		135431	137216
1.75	135429		135430		135431	137217

Standard: All rotary valves with standard accessories (end of shaft mount)

Optional: All rotary valves with handwheels or volume tanks (linkage design)

Table 26: NAMUR Accessory Mounting Kits	
Bracket Option	Description
28	20 mm pinion x 80 mm bolt spacing
28	38 mm pinion x 80 mm bolt spacing
313	30 mm pinion x 80 mm bolt spacing
513	50 mm pinion x 130 mm bolt spacing
Bolt Option	Description
A	10-24 UNC bolting
B	10-32 UNF bolting
L	M5-.8 metric bolting

Example: NK313A, NAMUR Accessory Mounting Kit with 30 mm pinion x 80 mm bolt spacing and 10-24 UNC bolting.

INDEX

A

Actuation Ratio · 40, 43, 67, 71
 Air Action Switch · 35
 Air Supply · 10
 Analog Output · 10, 52
 Auto Tune Switch · 35
 Auxiliary Card · 30, 40, 59

C

Calibration · 36, 37, 42, 44, 52, 67, 68, 69, 72, 73
 Characterization · 35, 45
 Command Source Reset · 38
 Compliance Voltage · 27
 Configuration Switch Settings · 35
 Continuous Stroke Test · 41

D

Date and Time · 40, 47
 Diagnostic Features · 51
 DIP Switch Override · 40
 Discrete Input · 52
 Discrete Output · 52
 Display Contrast · 41
 Double Acting Relay · 26, 62

E

Electrical Connections · 27
 Event History · 42, 43

F

Factory Reset · 38, 48
 FloTop Linear Valves · 16
 Friction · 36, 40, 41, 42, 43, 44, 67, 69, 70, 72, 73, 74

H

Handheld Communicator · 49
 HART · 5, 6, 10, 12, 41, 48, 49, 56
 Hazardous Area Certifications · 13

I

Inner Loop · 7
 Installation · 15

L

Language · 49
 LCD Board · 59
 LCD Menu · 40
 Limit Switch · 11, 32, 33, 53, 57
 Local Control Of Valve Position · 38
 Local User Interface · 34

M

Main Board · 61
 Maintenance · 14, 57
 Mark One Linear Valves · 15
 MaxFlo Rotary Valves · 20, 23
 Minimum Close Time · 45

Minimum Open Time · 45
 Mounting · 15
 Mounting Kits · 82
 Multi-Function Card · 10, 29, 48, 52, 53

N

NAMUR AutoMax Valves · 21

O

Outer Loop · 7

P

Partial Stroke Test · 42, 43, 51, 69
 Performance · 11
 Pneumatic Leak · 40, 43, 51, 67
 Positioner Dimensions · 77
 Pressure Control · 36, 41, 46
 Pressure Sensor Board · 61

Q

Quick Calibration Switch · 36
 Quick-Cal · 34

R

Remote Mount · 11, 33, 54
 Repair · 57

S

Safety · 5
 Shutoff · 47
 Signal at Closed Switch · 35
 Soft Limits · 47
 Spare Parts · 5, 80
 Specifications · 10
 Status Code · 37, 67, 68
 Status Icons · 40
 Status Messages · 40
 Stroke Calibration · 34, 37
 Stroke Time · 45

T

Temperature · 10, 11, 40, 42, 43, 47, 67
 Training · 40
 Troubleshooting · 27, 65
 Tubing · 24
 Tuning · 38, 44

V

Valtek Rotary Valves · 18
 Valve Action Switch · 35
 Valve Cycles · 43, 67
 Valve Stability Switch · 36
 Valve Travel · 43, 67
 ValveSight® DTM · 12, 49
 Vented Design · 25
 Version Numbers · 38, 48

Appendix 1: FM Control Drawing

FM REQUIREMENT ONLY

Class I, Division 2, Applications must be installed as specified in NEC Section 501-4 when barriers are not used. Installation for the A/O option should be per NEC 504.30.B Canadian Electric Code CSA C22.1.
(Refer to ANSI / ISA 12.06.01 for guidance on installation)

$U_o, V_o \text{ or } V_i < V_{max} \text{ or } U_i$
 $I_o, I_{sc} \text{ or } I_i < I_{max} \text{ or } I_i$
 $P_o \text{ or } P_i < P_i$
 $C_a \text{ or } C_o \geq C_i + C_{cable}$
 $L_a \text{ or } L_o \geq L_i + L_{cable}$
MAXIMUM NON-HAZARDOUS VOLTAGE MUST NOT EXCEED 250V

Install per drawing 364462

Special Condition for Safe Use

- To prevent the risk of electrostatic sparking the Logix apparatus Main enclosure and Logix Remote Mount enclosure shall only be cleaned with a damp cloth.
- The Logix apparatus main enclosure contains aluminum and is considered to present a potential risk of ignition by impact or friction. Care must be taken into account during installation and use to prevent impact or friction.

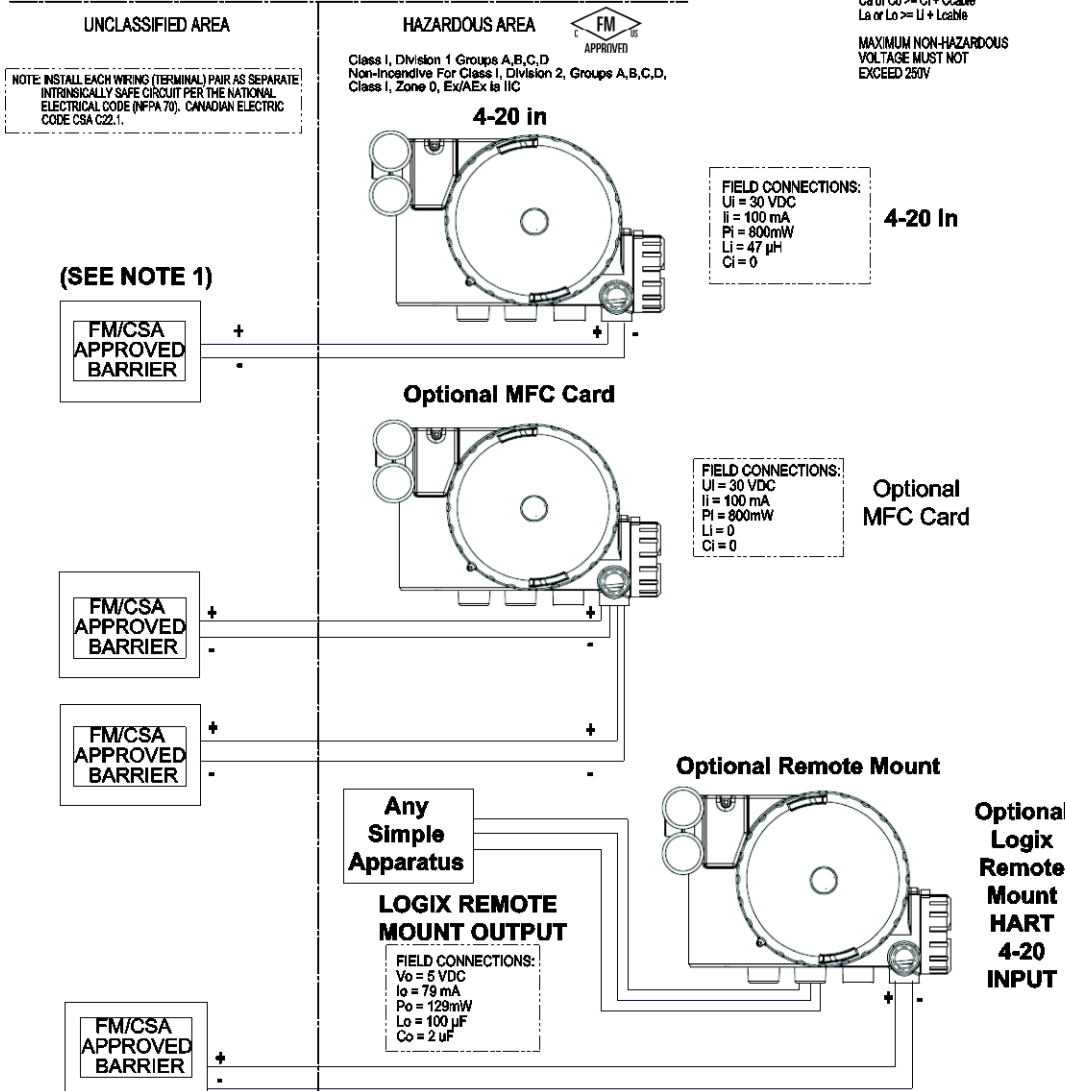

WIRING SCHEMATIC

OPTIONAL LOGIX REMOTE MOUNT POSITION SENSOR SIDE

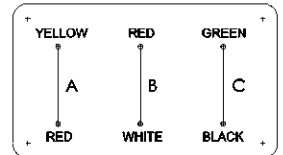

LOGIX 3000+ DIGITAL POSITIONER SIDE
 C1 AND C2 ARE CUSTOMER INSTALLED WIRING - USE 16-24 AWG WIRING WITH APPROPRIATE INSULATION FOR THE AREA.
 BARRIERS NOT REQUIRED ON C2

- Install per NFPA 70 article 501 and CSA C22.1
- WARNING:** To prevent ignition of flammable or combustible atmospheres, read, understand and adhere to the manufacturers live maintenance procedures.
- Barrriers not required for Division 2 locations.
- Barrriers need to be HART compliant

NOTES:

FM REQUIREMENTS
FIELD CONNECTIONS:
 $U_i = 30 \text{ VDC}$
 $I_i = 100 \text{ mA}$
 $P_i = 800 \text{ mW}$
 $L_i = 47 \mu\text{H}$
 $C_i = 0$



Flowserve Headquarters

5215 N. O'Connor Blvd. Suite 2300
Irving, Tx. 75039
Phone: +1 972 443 6500

Flowserve Corporation

Flow Control
1350 N. Mt. Springs Parkway
Springville, UT 84663 USA
Phone: +1 801 489 8611
Fax: +1 801 489 3719

Flowserve S.A.S.

12, avenue du Quebec
B.P. 645
91965 Courtaboeuf Cedex France
Phone: +33 (0) 1 60 92 32 51
Fax: +33 (0) 1 60 92 32 99

Flowserve Pte Ltd.

12 Tuas Avenue 20
Singapore 638824
Singapore
Phone: +65 6868 4600
Fax: +65 6862 4940

Flowserve Australia Pty Ltd.

14 Dalmore Drive
Scoresby, Victoria 3179 Australia
Phone: +61 7 32686866
Fax: +61 7 32685466

Flowserve Ltda .

Rua Tocantins, 128
São Caetano do Sul, SP 09580-130
Brazil
Phone: +55 11 2169 6300
Fax: +55 11 2169 6313

Flowserve Control Valves gmbH

Control Valves - Villach Operation
Kasernengasse 6
9500 Villach Austria
Phone: +43 (0)4242 41181 0
Fax: +43 (0)4242 41181 50

Flowserve (China)

585, Hanwei Plaza
7 Guanghau Road
Beijing, China 100004
Phone: +86 10 6561 1900

Flowserve India Controls

Pvt. Ltd Plot # 4, 1A, E.P.I.P,
Whitefield Bangalore Kamataka
India 560 066
Phone: +91 80 284 10 289
Fax: +91 80 284 10 286

Flowserve Essen GmbH

Schederhofstr. 71
45145 Essen Germany
Phone: +49 (0)201 8919 5
Fax: +49 (0)201 8919 600

NAF Ab

Gelbgjutaregatan 2
SE-581 87 Linköping Sweden
Phone: +46 (0)13 31 61 00
Fax: +46 (0)13 13 60 54

Bulletin FCD LGENIM0110-0 05/16

To find your local Flowserve representative please use the Sales Support Locator System found at www.flowserve.com

Or call

Europe +43 (0) 4242 41181 999

North America +1 801 489-2300

Asia + (65) 6879 8900

digitalproductstac@flowserve.com



Download 3200MD+ Manual

(Certification information in manual may not be applicable. Certifications on positioner label are valid.)

Flowserve Corporation has established industry leadership in the design and manufacture of its products. When properly selected, this Flowserve product is designed to perform its intended function safely during its useful life. However, the purchaser or user of Flowserve products should be aware that Flowserve products might be used in numerous applications under a wide variety of industrial service conditions. Although Flowserve can (and often does) provide general guidelines, it cannot provide specific data and warnings for all possible applications. The purchaser/user must therefore assume the ultimate responsibility for the proper sizing and selection, installation, operation, and maintenance of Flowserve products. The purchaser/user should read and understand the Installation Operation Maintenance (IOM) instructions included with the product, and train its employees and contractors in the safe use of Flowserve products in connection with the specific application.

While the information and specifications contained in this literature are believed to be accurate, they are supplied for informative purposes only and should not be considered certified or as a guarantee of satisfactory results by reliance thereon. Nothing contained herein is to be construed as a warranty or guarantee, express or implied, regarding any matter with respect to this product. Because Flowserve is continually improving and upgrading its product design, the specifications, dimensions and information contained herein are subject to change without notice. Should any question arise concerning these provisions, the purchaser/user should contact Flowserve Corporation at any one of its worldwide operations or offices.

© 2012 Flowserve Corporation, Irving, Texas, USA. Flowserve is a registered trademark of Flowserve Corporation.

For more information about Flowserve Corporation, contact www.flowserve.com or call USA 1-800-225-6989.

3200MD+ Installation, Operation, Maintenance, and Safety Manual

Revision History

Description	Date	Rev
Initial Draft	March 12, 2011	A
Changed UI figures. Change Hazardous Location Certs to remove IS and NI references per Steve C. Changed Model Code Chart	February 3, 2016	B
Added note to model code chart on page 54 that says M20 Threads are not available for certification code 34 and added the same note on page 25. Changed certification labels on page 14. Updated Table 11 on page 12 and put IS and NI back in.	April 14, 2016	C
Changed certification labels on page 14. Updated Table 11 on page 12. Updated Table 11 on page 13	April 27, 2016	D
Removed SIL reference from Table 18	May 16, 2016	E
Changed Figure 33 for better clarification about cable placement and revised Section 14.3, Installation Step 3 for better explanation. Added Disposal Instructions (Section 1.9)	May 17, 2016	F
Fixed the text in Section 9.3 to make it clearer. Fixed Table Numbers	May 20, 2016	G
Changed the beginning sections and reformatted as directed by new Corporate template. Added Mike Samuels' edits.	May 31, 2016	H

Approvals (Signatures required for changes to Section 3)

Name	Signature	Date	Rev
Kent Woolf (author)			
Ken Beatty			
Jeff Taylor			
Steve Christiansen			
Doug Forman			

Distribution

Name	Function
Doug Forman	Engineering
Nate Higbee	Engineering
Dave Nagel	Engineering
Ed Silva	Engineering
Mike Yost	Engineering
Mitch Price	Engineering
Brent Lingwall	Engineering
Edwin Hordijk	Sales
Ricardo Tozzi	Sales
Kalpesh Solaki	Sales
Mike Waier	Sales
Chin Thye Boo	Sales
Dmitry Gerasimov	Russian Translation
Darren	Russian Translation

To Do Next Revision:

This page not to be published.