



USER INSTRUCTIONS

Installation

Operation

Maintenance

Valtek Control Valves

Logix[®] Remote Mount Option

FCD LGENIM0001-01 8/13

Description:

The Logix[®] Remote Mount option is intended for use where the positioner may be inaccessible when mounted to the valve/actuator package or when vibration or other operating factors may exceed the Logix[®] positioner recommended operating conditions. The Logix[®] remote mount option consists of two (2) components: The Logix[®] positioner configured for remote mount operation, and the remote feedback unit. The remote feedback unit must be wired to the Logix[®] positioner following applicable standards for hazardous location installations.

NOTE: For Logix 3200 positioner operation refer to Instruction, Operation and Maintenance Manual LGENIM0059. For the Logix 520MD+ positioner operation refer to IOM LGENIM0105.

Installation:

To mount a Logix Low Profile Remote Mount to a Valtek linear Mark One valve, refer to Figure 1: Mounting to Mark I Linear Valves and proceed as outlined below.

 **CAUTION:** Remember to remove the air supply from the Logix positioner before installing the remote mount unit.

 **NOTE:** The feedback shaft has a clutch mechanism that allows for over-rotation of the shaft for easy adjustments.

- 1 Remove washer and nut from follower pin assembly. Insert pin into the appropriate hole in follower arm, based on stroke length. The stroke lengths are stamped next to their corresponding holes in the follower arms. Make sure the unthreaded end of the pin is on the stamped side of the arm. Reinstall lock washer and tighten nut to complete follower arm assembly.
- 2 Slide the slot in the follower arm assembly over the flats on the position feedback shaft in the back of the positioner. Make sure the arm is pointing toward the side of the positioner with ports A, B, and Supply. Slide the lock washer over the threads on the shaft and tighten down the nut.
- 3 Align the bracket with the three outer mounting holes on the positioner. Fasten with 1/4" bolts.
- 4 Screw one mounting bolt into the hole on the yoke mounting pad nearest the cylinder. Stop when the bolt is approximately 3/16" from being flush with mounting pad.
- 5 Slip the large end of the teardrop shaped mounting hole in the back of the positioner/bracket assembly over the mounting bolt. Slide the small end of the teardrop under the mounting bolt and align the lower mounting hole. Insert the lower mounting bolt and tighten the bolting.
- 6 Position the take-off arm mounting slot against the stem clamp mounting pad. Apply Loctite 222 to the take-off arm bolting and insert through washers into stem clamp. Leave bolts loose.
- 7 Slide the appropriate pin slot of the take-off arm, based on stroke length, over the follower arm pin. The appropriate stroke lengths are stamped by each pin slot.

 **NOTE:** The feedback shaft has a clutch mechanism that allows for over-rotation of the shaft for easy adjustments.

- 8 Center the take-off arm on the rolling sleeve of the follower pin.
- 9 Align the take-off arm with the top plane of the stem clamp and tighten bolting. Torque to 120 in-lb.

➤ **NOTE:** *If mounted properly, the follower arm should be horizontal when the valve is at 50% stroke and should move approximately $\pm 30^\circ$ from horizontal over the full stroke of the valve. If mounted incorrectly, a stroke calibration error will occur and the indicator lights will blink a GYGG code indicating the position sensor has gone out of range on one end of travel or the travel is too small. Reposition the feedback linkage or rotate the position sensor to correct the error.*

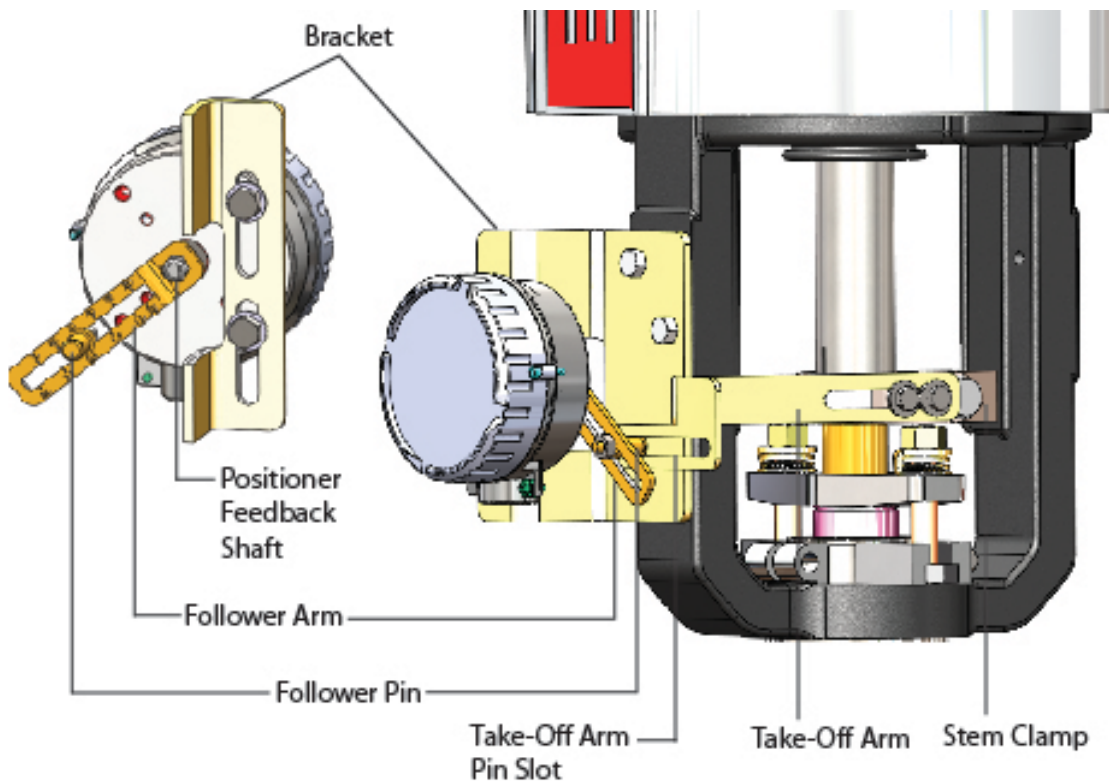

Figure 1: Mounting to Mark I Linear Valves

Mounting to Standard Valtek Rotary Valves

⚠ CAUTION: Remember to remove the air supply from the Logix positioner before installing the remote mount unit.

🔄 NOTE: The feedback shaft has a clutch mechanism that allows for over-rotation of the shaft for easy adjustments.

The standard rotary mounting applies to Valtek valve/actuator assemblies that do not have mounted volume tanks or hand-wheels. The standard mounting uses a linkage directly coupled to the valve shaft. This linkage has been designed to allow for minimal misalignment between the positioner and the actuator.

- 1 Fasten the spline lever adapter to the splined lever using two 6 x 1/2" self-tapping screws. (Figure 2)
- 2 Slide the take-off arm onto the spline lever adapter shaft, orienting the arm to the current valve position. Insert the screw with star washer through the take-off arm and add the second star washer and nut and tighten.

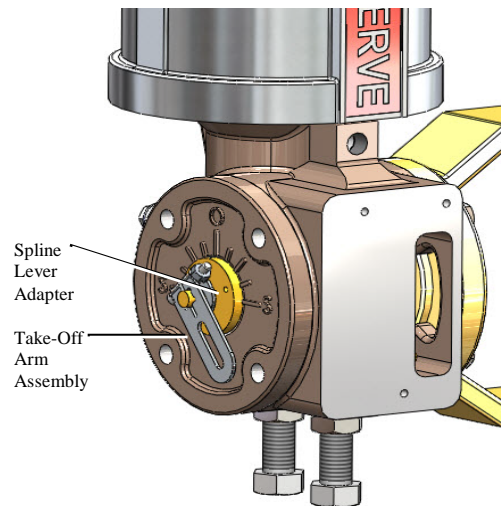

Figure 2: Valtek Rotary Take-Off Arm

- 3 Attach follower arm to positioner feedback shaft using the star washer and 10-32 nut. (Figure 3)
- 4 Rotate the follower arm so the follower pin will slide into the slot on the take-off arm. Adjust the bracket position as needed noting the engagement of the follower pin and the take-off arm slot. The pin should extend approximately 2 mm past the take-off arm. When properly adjusted, securely tighten the bracketing bolts.
- 5 Using four 1/4-20 x 1/2" bolts, fasten remote mount unit to universal bracket using appropriate hole pattern (stamped on bracket). (Figure 3)

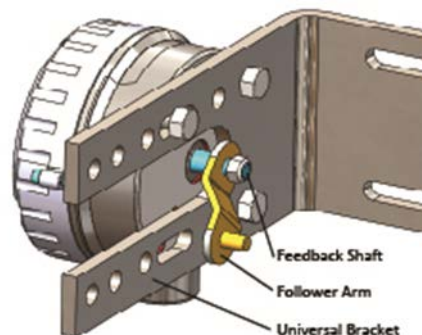

Figure 3: Valtek Rotary Follower Arm

- 6 Using a ½" end wrench and two 5/16-18 X ½" bolts, attach bracket to actuator transfer case pad. Leave these bolts slightly loose until final adjustments are made.

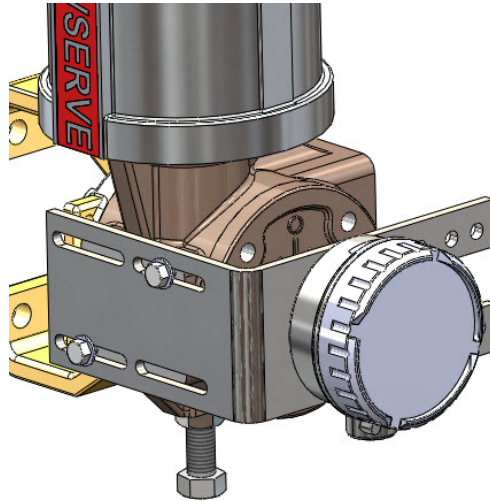

Figure 4: Valtek Rotary Mounting

- 7 Rotate follower arm so the follower pin will slide into the slot on the take-off arm. Over-rotate the follower arm if needed so the arm moves freely through the intended travel. (Figure 5)
- 8 Adjust the bracket position as needed noting the engagement of the follower pin and the take-off arm slot. The pin should extend approximately 1/16" past the take-off arm. When properly adjusted, securely tighten the bracketing bolts.

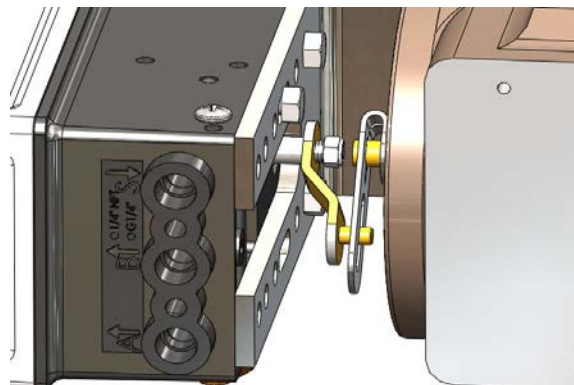

Figure 5: Valtek Rotary

➔ **NOTE:** If mounted properly, the follower arm should be horizontal when the valve is at 50% stroke and should move approximately $\pm 30^\circ$ from horizontal over the full stroke of the valve.

Mounting to MaxFlo Rotary Valves

⚠ CAUTION: Remember to remove the air supply from the Logix positioner before installing the remote mount unit.

🔄 NOTE: The feedback shaft has a clutch mechanism that allows for over-rotation of the shaft for easy adjustments.

- 1 Slide the take-off arm onto the shaft. Insert the screw with star washer through the take-off arm and add the second star washer and nut. Tighten nut with socket so arm is lightly snug on the shaft but still able to rotate. This will be tightened after linkage is correctly oriented. (Figure 6)

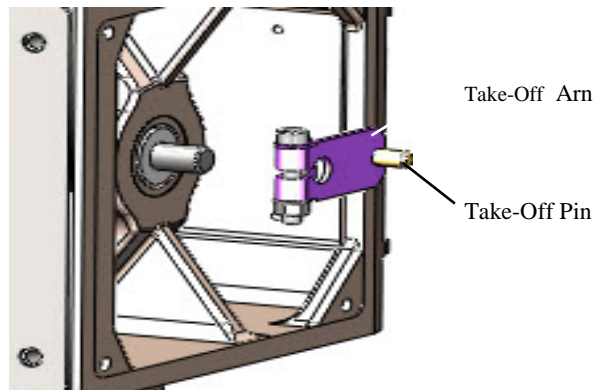

Figure 6: MaxFlo Take-Off Arm

- 2 Attach the mounting plate to the positioner using 4 screws. (Figure 7)
- 3 Attach follower arm to positioner feedback shaft.

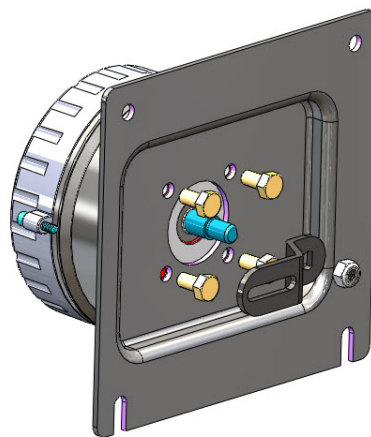

Figure 7: MaxFlo Follower Arm

- 4 Rotate the follower arm so the take-off pin will slide into the slot on the follower arm. Adjust the bracket position as needed noting the engagement of the follower pin and the take-off arm slot. The pin should extend approximately 2 mm past the take-off arm. When properly adjusted, securely tighten the bracketing bolts. (Figures 8&9)

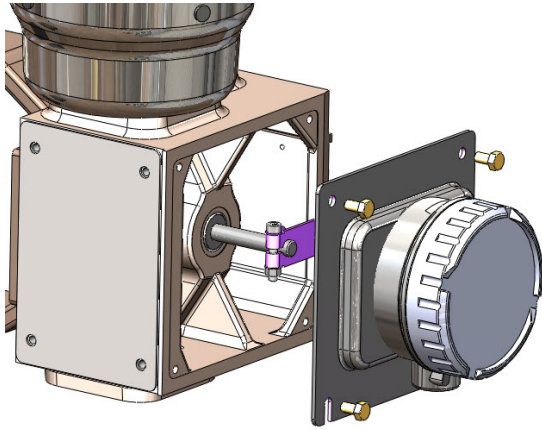

Figure: 8 MaxFlo Assembly

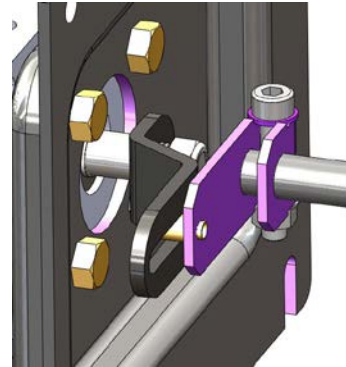

Figure 9: MaxFlo Connection

Mounting to Rotary NAMUR (AutoMax) Valves

⚠ CAUTION: Remember to remove the air supply from the Logix positioner before installing the remote mount unit.

➡ NOTE: The feedback shaft has a clutch mechanism that allows for over-rotation of the shaft for easy adjustments

- 1 Attach the mounting plate to the positioner using 4 screws. (Figure 10)
- 2 Rotate the feedback shaft to match the orientation of the receiver on the actuator.
- 3 Mount the positioner onto the actuator using the washers and nuts. (figure 11)

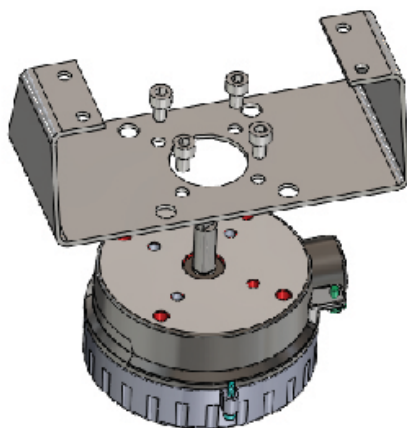

Figure: 10 Automax Bracket

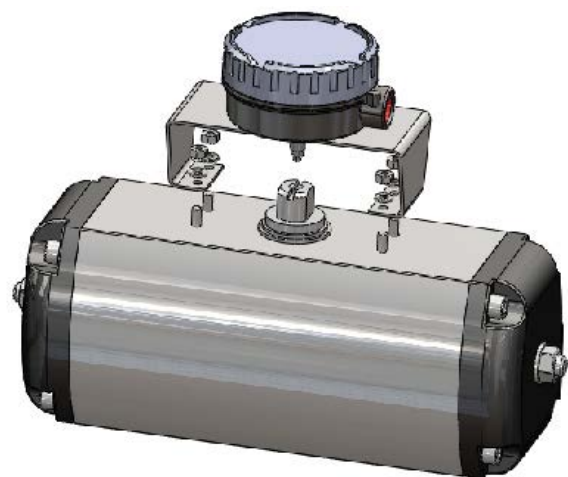

Figure: 11 Automax Assembly

Wiring Instructions:

1. Remove the outer Main Housing Covers of both the Logix 3200IQ/MD and the Low Profile Position Sensor Module.



Logix 3200MD

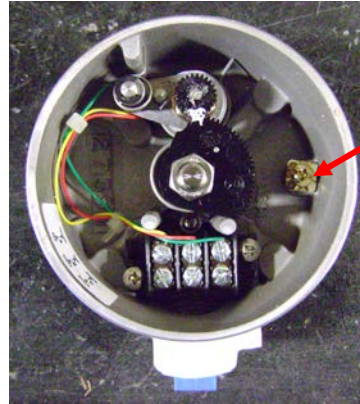

Low Profile Remote Mount

Ground Screw
Cable shielding
should be grounded
here

2. Remove the grey Main Board Cover on the Logix 3200IQ/MD.



3. Attach wires from the Low Profile Position Sensor Module's terminal strip to the 3200IQ/MD terminal strip; 16 AWG wire is recommended but no less than 22 or 24 AWG should be used to minimize line impedance. Be sure to run the wires through the threaded conduits and to connect terminal A to terminal A, B to B, and C to C. The cable shielding should be connected to the ground screw located inside the Remote Mount housing. The Positioner end of the cable is not grounded, and should be insulated to prevent accidental grounding inside the Positioner housing.

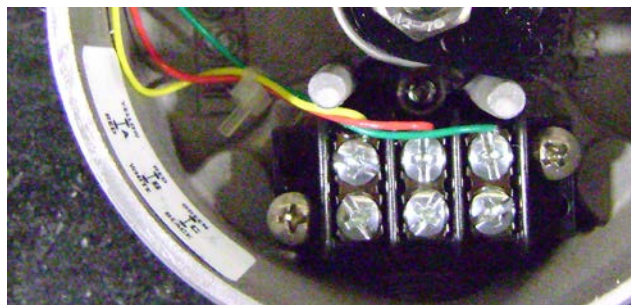



USER INSTRUCTIONS

4. Replace all covers and seal all the conduit entry ways appropriately for the area of installation.
5. Perform the Quick-Cal on the 3200IQ/MD to calibrate the position sensor. This step may need to be repeated up to 4 times to let the de-clutch mechanism on the shaft to adjust automatically to the stroke of the valve.

Hazardous Location Ratings and Information

!Warning!

- **Low Profile Position Sensor Modules are certified as a system in combination with the Logix 3200 and Logix 520MD+ Positioner. Do not connect the remote mount to any other device.**
- **Only install Low Profile Position Sensor Modules to Logix 3200 and Logix 520MD+ Positioners that have the same hazardous location ratings and protection concepts.**
- **Use only the conduit entry ways provided.**
- **Do not install a Low Profile Position Sensor Module more than 100ft away from the Logix 3200.**
- **Disconnect Power to the Logix 3200 or Logix 520MD+ Positioner before opening the Low Profile Position Sensor Module.**
- **Installations to the Logix 3200, Logix 520MD+ and the Low Profile Position Sensor Module must meet all applicable regulatory requirements appropriate for the method of protection used. For US installations refer to NEC section 500 and for Europe refer to EN 60079-14**
- **Intrinsically Safe installations require a barrier to be installed previous to the terminations of the Logix 3200 or Logix 520MD+. Consult the Logix 3200 or Logix 520MD+ IOM for Entity Parameters. Barriers are not required between the Logix 3200 and the Low Profile Position Sensor Module.**
- **If Cable Glands are utilized in the installation ensure they are appropriately rated for the area classification and have a minimum IP rating of IP65.**

<p style="text-align: center;"><u>ATEX</u> <u>Logix 3200IQ/MD</u></p> <p><u>Intrinsic Safety</u> II 1 G Ex ia IIC T4/T5 Ga T4 Ta = -52°C to +85°C T5 Ta = -52°C to +55°C</p> <p>Ex iaD 20 T95°C Ta = -52°C to +80°C</p> <p style="text-align: center;"><u>Logix 520MD+</u></p> <p><u>Intrinsically Safe</u> II 1 G Ex ia IIC T4/T6 Ga IP68</p> <p><u>Non-Incendive</u> II 2 G Ex nA IIB T4 Gc</p> <p><u>Dust Proof</u> Ex tb IIIC T4 Db T4@Tz = -52°C to +85°C T6@Ta = -52°C to +45°C</p>	<p style="text-align: center;"><u>USA</u> <u>Logix 3200IQ/MD</u></p> <p><u>Explosion Proof</u> Class I, Division 1, Group B,C,D T6 DIP, Class II, III, Division 1, Group E,F,G T6 T6 Ta = 60°C Type 4x</p> <p><u>Intrinsically Safe</u> Class I, II, III, Division 1, Group A-G T4/T5 Class I, Zone 0 AExia IIC T4/T5 T4 Ta = 85°C T5 Ta = 55°C</p> <p><u>Non Incendive</u> Class I, Division 2, Groups A,B,C,D T4/T5 T4 Ta = 85°C T5 Ta = 55°C</p> <p style="text-align: center;"><u>Logix 520MD+</u></p> <p><u>Intrinsically Safe</u> Class I, Div 1 Grps A-D T4-T6 Class I,III, Div 1 Grps D,E,F, T4 Class I, Zone 0 AEx ia IIC T4/T6 Class 1, Zone 0, Ex ia IIC T4/T6</p> <p><u>Non-Incendive</u> Class I, Div 2 Grps A-D T4/T6 T4@ Ta = -52°C to +85°C T6@ Ta = -52°C to +45°C</p>
<p><u>Special Conditions for Safe Use</u></p> <ul style="list-style-type: none"> • Equipment must be installed in such a manner as to avoid possible impacts or friction with other metal surfaces. 	
<p><u>Logix 520MD+ Special Conditions for Safe Use</u></p> <ul style="list-style-type: none"> • DO NOT REMOVE THE BATTERY • Potential Electrostatic Charging Hazard – Clean only with a damp cloth. • Substitution of components may impair safety. • Install equipment in a manner that minimizes risks of impact or friction with metal surfaces. 	



USER INSTRUCTIONS

Selection		Code	Example
		3	3
Protocol	HART	2	2
Diagnostics	Standard	0	1
	Advanced (with pressure sensing)	1	
	Pro (with sensing and full ValveSight diagnostics)	2	
Material	Aluminum, White Paint (Valtek)	0	0
	Stainless Steel, No Paint (Valtek)	1	
	Aluminum, Black Paint (Automax)	2	
	Aluminum, Food-Grade White Paint (Automax)	3	
	Aluminum, Black Paint (Accord)	4	
	Aluminum, Food-Grade White Paint (Accord)	5	
Design Version			MD
Certifications	FM Metal Nameplate - Explosion Proof	01	10
	FM Metal Nameplate - Intrinsically Safe	02	
	INMETRO Mylar Multiple Concept Label Ex ia IIC T4/T5; Ex d IIB+H T5 (Brazil)	06	
	ATEX Metal Nameplate - II 2 G D; Ex d IIB+H2, Ex tD A21. (GOST GGTN Ex d IIB+H2)	07	
	North America Metal Nameplate Explosion Proof Class Intrinsically Safe: Non-Incendive.	10	
	General Purpose	14	
	ATEX Metal Nameplate - II 1 G D; Ex ia IIC, Ex iaD A20 (Gost GGTN Ex I IIC)	15	
	IECEX Metal Nameplate - Ex d IIB+H2 (Kosha Ex d)	16	
	IECEX Metal Nameplate - Ex ia IIC	21	
	ATEX: Mylar, Multiple Concept Label: Explosion Proof: II2G Ex d IIB+H T5; II2D Ex tD A21 Intrinsically Safe: II1G Ex ia IIC, T4 II1D Ex iaD 20 T95 °C Non-incendive: II3G Ex nL nA IIC, T4 II3D Ex tD A22 T95 °C	28	
	IECEX : Mylar Multiple Concept Label; Explosion Proof, Ex d IIB+ H2, Intrinsically Safe Ex ia IIC	33	
North America: Mylar Multiple Concept Label FM/CSA, Explosion Proof, Intrinsically Safe Non-Incendive KOSHA* Ex d IIB+H2	34 35		
Shaft	DD 316 Stainless Steel Shaft (Valtek Standard)	D6	D6
	NAMUR 316 Stainless Steel (VDI/VDE 3845)	N6	
Conduit Connections	1/2 in. NPT	E	M
	M20	M	
Action	Four-way (Double-Acting)	04	4V
	Three-way (Single-Acting)	03	
	Four-way Vented (Double-Acting)	4V	
	Three-way Vented (Single-Acting)	3V	
Temperature	Low Temperature (refer to certification table)	40	40
Gauges	SS with brass internals, psi (bar/kPa) (Valtek Standard)	OG	KS
	SS with SS internals, psi (bar/kPa)	OS	
	SS with brass internals, psi (kg/cm ²)	KG	
	SS with SS internals, psi (kg/cm ²) KS	KS	
	No Gauges	U	
Special Options	No Special Options	00	OF
	4-20 mA Position Feedback	OF	
	Remote Mount Feedback	RM	
	Fail Option Feedback *	SF	

For each category, select the code for one of the options. ➔ **NOTE:** Field conversions to remote mount are not allowed with certified product.

*Contact factory before specifying this option ➔ **NOTE:** Replacement components are not available. Contact your Flowserve representative for repairs.



USER INSTRUCTIONS

520MD+ MODEL CODE SPECIFICATION

Selection	Description	Code	Example
Body	Intrinsically Safe, IP-26	5	5
Communications	HART ¹	2	5 2
Diagnostics	Standard (Basic Functionality) ²	0MD+	1MD+
	Advanced (With Pressure Sensing)	1MD+	
	Pro (With Full ValveSight Diagnostics)	2MD+	
Certifications	General Purpose	14	37
	North America/ATEX/IECEX Ex ia	37	
-			
Housing	Aluminum - Black Base with White Cover	W	W
	Aluminum - Black Base with Yellow Cover	Y	
	Aluminum - Black Base with Black Cover (Automax)	B	
	Aluminum - Black Base with Black Cover (Accord)	A	
Threaded Connections	Mounting: 5/16" 18 UNC, Pneumatics: 1/4" NPTF, Conduit: 1/2" NPTF, Vents 1/4" NPTF	1	1
	Mounting: M8 x 1.25, Pneumatics: 1/4" NPTF, Conduit: M20 x 1.5, Vents 1/4" NPTF	2	
	Mounting: M8 x 1.25, Pneumatics: G1/4", Conduit: M20 x 1.5, Vents G1/4"	3	
Shaft	D - 316 Stainless Steel Shaft (Valtek Standard)	D	D
	NAMUR - 316 Stainless Steel Shaft (VDI/VDE 3845)	R	
Action	Three_way_Single_Acting_Poppet_Style_Relay	1	1
	Three_way_Single_Acting_Spool_Style_Relay	2	
	Four_way_Double_Acting_Spool_Style_Relay	3	
Positioner Indication	No Indicator	0	1
	Flat Indicator	F	
	Domed Indicator	D	
Special Options	No special options	0	0
-			
Manifold	No_Manifold	00	0
	Gauge_Manifold_Aluminum	GM	
Gages	No Gauges	0	0
	Nickel Plated with Brass Internals, psi (bar/kPa)	1	
	Nickel Plated with Brass Internals, psi (kg/cm2)	2	
	SS with SS Internals, psi (bar/kPa)	3	
	SS with SS Internals, psi (kg/cm2)	4	
	UCC Press Test Plug, 1/8" NPT	A	
	Valve, Tank, Schrader 645A	B	
-			
Display	No LCD	0	1
	LCD	1	
Auxiliary Card Slot 1	Slot 1 - No Card	0	0
	Slot 1 - Multi-Function Card ^{3,4}	1	
Auxiliary Card Slot 2	Slot 2 - No Card	0	0
	Slot 2 - Multi-Function Card ^{3,4}	1	
Switches	No Switches	0	0
	Mechanical Limit Switch ⁵	1	
	Reed Switch	2	
	Namur V3 type proximity switch, P+F NJ2-V3-N ⁴	3	
	Slot Type NAMUR Sensor, P+F SJ2 S1N ⁴	4	
	Slot Type NAMUR Sensor, P+F SJ2 SN ⁴	5	
	Namur V3 type proximity switch, P+F NBB2-V3-E2 ⁴	6	
	Remote Mount Feedback ^{4,7}	7	

HART 6 standard. Can be configured as HART 5 in the field.

Can be upgraded to 521MD+ or 522MD+ in the field.

Can be configured as Analog Output, Discrete Output or Discrete Input in the field.

Only available for general purpose (certification option 14).

Available for Cookeville and China markets only.

"Positioner Only" diagnostics. No LCD. No Aux Cards.

The low profile remote mount module is included with this option and may be shipped separately.



USER INSTRUCTIONS

Flowserve Corporation

1350 Mountain Springs Pkwy
Springville, Utah
USA
801 489-8611

Flowserve S.A.S.

12, avenue du Quebec
B.P. 645
91965 Courtaboeuf Cedex
France
Phone: 33 (0) 1 60 92 32 51
Fax: 33 (0) 1 60 92 32 99

Flowserve Pte Ltd.

12 Tuas Avenue 20
Singapore 638824
Singapore
Phone: 65 6868 4600
Fax: 65 6862 4940

Flowserve Australia Pty Ltd.

14 Dalmore Drive
Scoresby, Victoria 3179
Australia
Phone: 61 7 32686866
Fax: 61 7 32685466

Flowserve Ltda.

Rua Tocantins, 128
São Caetano do Sul, SP 09580-130
Brazil
Phone: 55 11 2169 6300
Fax: 55 11 2169 6313

Bulletin FCD LGENIM0001-01 8/13

To find your local Flowserve representative please use the Sales Support Locator System found at www.flowserve.com

Or call : 1-801-489-8611

Flowserve Corporation has established industry leadership in the design and manufacture of its products. When properly selected, this Flowserve product is designed to perform its intended function safely during its useful life. However, the purchaser or user of Flowserve products should be aware that Flowserve products might be used in numerous applications under a wide variety of industrial service conditions. Although Flowserve can provide general guidelines, it cannot provide specific data and warnings for all possible applications. The purchaser/user must therefore assume the ultimate responsibility for the proper sizing and selection, installation, operation, and maintenance of Flowserve products. The purchaser/user should read and understand the (INSERT OFFICIAL USER INSTRUCTION TITLE) instructions included with the product, and train its employees and contractors in the safe use of Flowserve products in connection with the specific application.

While the information and specifications contained in this literature are believed to be accurate, they are supplied for informative purposes only and should not be considered certified or as a guarantee of satisfactory results by reliance thereon. Nothing contained herein is to be construed as a warranty or guarantee, express or implied, regarding any matter with respect to this product. Because Flowserve is continually improving and upgrading its product design, the specifications, dimensions and information contained herein are subject to change without notice. Should any question arise concerning these provisions, the purchaser/user should contact Flowserve Corporation at any one of its worldwide operations or offices.

For more information about Flowserve Corporation, contact www.flowserve.com or call USA 1-800-225-6989.