

FlowAct

Diaphragm Linear Actuator

FCD VLENIMFACTA4 10/16

Installation
Operation
Maintenance



Diaphragm Linear Actuator - FlowAct

Diaphragm actuators take the form of a flexible diaphragm, placed between two casings. The upper section of the two chambers is designed pressure tight, the lower chamber holds a spring opposing the force generated within the pressure chamber of the actuator. The controlled air supply is connected to the pressure tight chamber, and an increase or decrease of the air pressure results in a positioning force of the stem. This kind of actuator is called single acting with spring return positioning force for linear motion. The linear motion / stroke is limited by a stroke range from 10 - 100 mm and a positioning force range from 500 - 60.000 N dependent on the actuator size. The actuator parts are designed so that the actuator can be assembled in two fail safe positions, close or open. Simplicity of design reduces maintenance and parts inventory costs. It is ideally suited for flow and pressure control of liquid and gas media in oil and gas, power, chemical and petrochemical processing and related industries. The FlowAct is manufactured to ISO 9001 standards.

The following instructions are designed to assist in unpacking, installing and performing maintenance as required on Flowserve FlowAct diaphragm linear actuators. This instruction manual does not include specific product design data. Such data can be found on the actuator's serial plate or specification documents; additionally, dimensional information can be found in the FlowAct technical bulletin. Procure needed documents as necessary before you begin any work on the valve.

User Instructions cannot deal with all possible situations and installation options. It is required that only trained and qualified technicians are authorized to adjust, repair or work on diaphragm linear actuators, positioners and other accessories. Review this bulletin prior to installing, operating or performing any maintenance on the actuator. Additional Installation, Operation, and Maintenance Instructions (IOMs) cover other features (such as positioners and other accessories).

To avoid possible injury to personnel or damage to actuator parts, WARNING and NOTICE indicators must be strictly followed. Modifying this product, substituting non-factory parts or using maintenance procedures other than outlined could drastically affect performance and be hazardous to personnel and equipment and may void existing warranties. This manual should be used in conjunction with applicable local and national laws. Failure to comply with User Instructions will render the manufacturer's guarantee and liability null and void. Unless otherwise agreed, the manufacturer's general terms and conditions of sale shall apply.

**Read the user instructions carefully before use.
Keep for future reference.**

Contents

1	Scope of Manual	3	7	Storage	4	13	Troubleshooting	12 - 13
2	Intended Use	3	8	Unpacking	4 - 5	14	Operating the Handwheel	13
3	Product Identification	3	9	Installation	5 - 8	15	Disassembly and Reassembly	13 - 73
4	Modification	3 - 4	10	Assembly on valve	8 - 10	16	Torque Requirements	74
5	Safety	4	11	Actuator Quick-Check	10 - 11	17	Lubricants	74
6	Packaging and Transport	4	12	Actuator Maintenance	11 - 12	18	Disposal	75

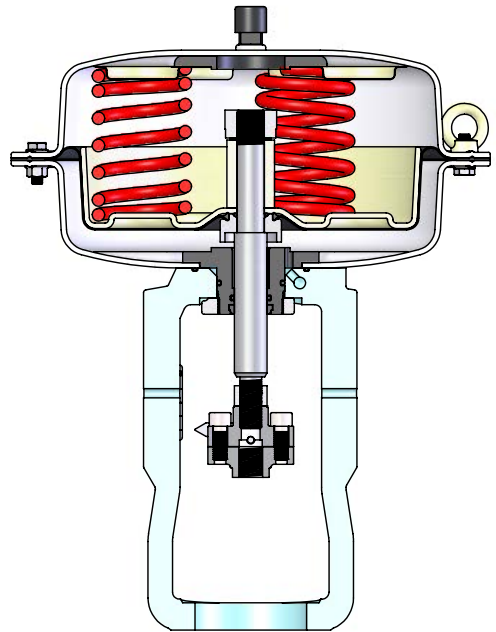

Figure 1: FlowAct - Actuator, Spring close

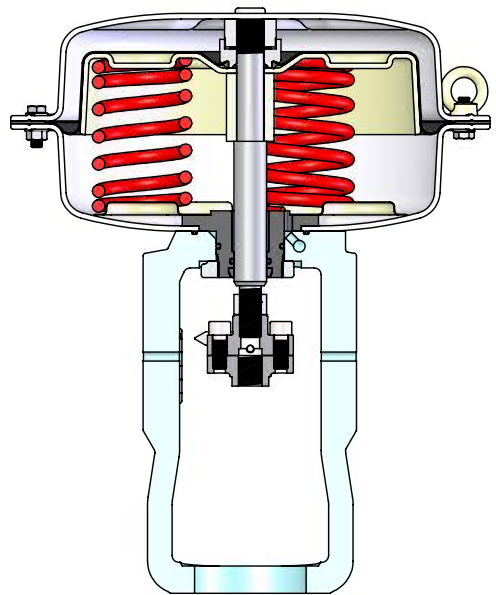

Figure 2: FlowAct - Actuator, Spring opens

1 Scope of Manual

The following user information covers the FlowAct diaphragm linear actuator:

- Preferable for Flowserve - Villach valve product lines
- For the product range of

Type	Positioning Force (N)	Stroke (mm)
253	500 - 12 500	10 - 20
503	1 000 - 25 000	20 - 40
701	1 400 - 35 000	20 - 60
1502	3 000 - 60 000	20 - 100
3002	6 000 - 60 000	40 - 100

- Air supply max. 6 bar or as indicated on the type plate
- Protection class IP 54, with air purging IP 64
- Without or with attachments like:
 - top mounted handwheel
 - top mounted adjustable stroke limitation - max. 39 kN
 - side-mounted handwheel - max. 39 kN
 - central-mounted handwheel
- Comes with or without ancillary equipment

2 Intended Use

WARNING Diaphragm linear actuators are pressure vessels designed and rated for specific application conditions. Before installation, check the serial number and / or the tag number to ensure that the valve and actuator being installed are correct for the intended application. Do not use the valve assembly outside of its rated design limits. Exceeding the design limits may cause hazardous conditions including leakage of the process media or rupture of the pressure boundary resulting in possible process loss, equipment or environmental damage, or serious personal injury or death.

Specific product design data can be found on the actuators serial plate, data sheet and the calculation sheet (in acc. to the IEC 60534-7:2010).

The FlowAct handles a wide variety of general service applications.

The FlowAct consists of the actuator, yoke and attachments and accessories. The actuator is designed with a high level of interchangeability allowing the user to assemble the greatest possible number of variations from a minimum number of

components to match each application. There are two fail safe positions, close or open without or with attachments.

The FlowAct is designed in compliance with **EN 1349:2009** - Industrial Process Control Valves (DIN EN 1349 and VDE 0409-1349).

The FlowAct actuator is designed for use in **MODERATE** and **WORLDWIDE** environmental conditions, standard ambient temperature range -40°C to +80°C (-40°F to 176°F). A special version is available with conditions up to -60°C, air humidity up to 93% non-condensing, air pollution up to 300 µg/m³, (unless restricted by the accessories).

The product offering may include optional ancillary equipment, such as positioners, air-filter regulators, solenoid valves, limit switches or boosters. Digital, I/P, or pneumatic positioners can be mounted direct or with a mounting bracket. Refer to the relevant manufacturer's user instructions for information regarding other ancillary equipment.

3 Product Identification

Each FlowAct diaphragm linear actuator comes with an attached serial plate which includes key information specifically for each actuator:

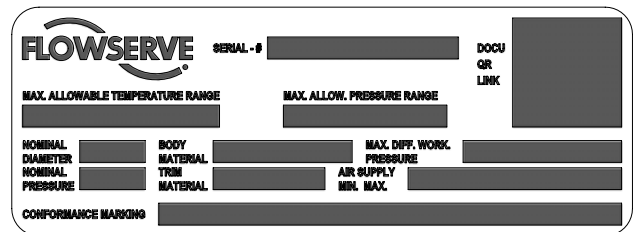

Figure 3: Serial Plate (Example)

The same serial number shown on the plate will appear on all FlowAct data sheets, dimensional drawings, bills of material, and spare parts lists. Other information located on the serial plate is self-explanatory for the FlowAct actuator.

You can download .pdf versions of the FlowAct documentation including a sales brochure, technical bulletin and user instructions at www.flowserve.com. It is the user's responsibility to keep this and related documentation on file and accessible for the FlowAct product.

4 FlowAct Modification

FlowAct linear actuators are generally delivered as tested and assembled units.

Unauthorized modification of the FlowAct diaphragm linear actuator voids the product test certification and product warranties, could drastically affect product performance and could be hazardous to personnel and equipment.

NOTICE Before FlowAct re-installation, all necessary tests must be repeated and recorded in compliance with all test routines, guidelines and engineering standards.

5 Safety

Safety terms - WARNING and NOTICE - are used to highlight specific dangers and / or provide additional information that may not be readily apparent in the User Instructions. WARNING directions must be strictly followed.

WARNING or **WARNING** indicates that severe personal injury, death and substantial property damage can occur if proper precautions are not taken.

NOTICE NOTICE indicates practices or provides additional technical information.

Grey fields indicate safety-related informations.

6 Packaging and Transport

Pay close attention to shipping marks and transport pictograms.

Careful packing, loading and transport arrangements are required to prevent products from being damaged during transport. Standard packaging includes a cardboard box, with or without a wooden pallet base as needed. Special packaging may include a wooden box. Packaging may use cardboard, plastic wrap, foam, or paper as packing material. Filling material may be a carton type or paper.

Shipping marks display product and package dimensions and weight (for further information request Packaging and Sending Instructions, Form L 002). Packing guidelines for export

follow HPE standards. (Nonreturnable packaging may contain up to 90% recyclable materials.)

7 Storage

Maximum storage time for diaphragm linear actuators is 2 years at 25 °C.

NOTICE Rubber becomes brittle, lubricants become resinous, see also ISO 2230.

Upon arrival on site, store the FlowAct actuator on a solid base in a cool, dry closed room. Until its installation, the actuator must be protected from the weather, dirt and other potentially harmful influences.

Do not remove the protective covers from the air supply connection of the actuator or from the instrument and accessories until the actuator is ready for installation at the site.

8 Unpacking

Hoisting and lifting are inherently dangerous activities and require safe rigging and proper training to mitigate hazards. Use standard industry safety practices, personal protection, and warranted lifting devices.

WARNING Crushing hazard ! Arrange rigging to prevent tipping of the actuator. Do not allow the actuator assembly to rotate during removal. Do not stand under suspended loads. Failure to do so can cause serious personal injury and damage the actuator or nearby equipment.

NOTICE Be aware that the center of gravity may be above or beside the lifting point. Do not allow the sling to touch the stem, travel indicator or peripheral equipment. Observe the maximum permitted carrying capacity.

1. Check the packing list against materials received to ensure all components and accessories are present.
2. Place and hook a double-leg sling (if necessary a triple-leg sling) into the lifting rings mounted on the actuator.

3. You can alternatively place a sling around the actuator case just above the yoke.
4. Upon removing the actuator from the packaging, we recommend that you:
 - Promptly touch up any damage to the paint that offers corrosion protection.
 - Contact your shipper immediately to report any damage.
 - Call your Flowserve representative if you experience any problems.

Do not remove the protective covers from the air supply connection of the actuator or from the instrument ports of the actuator and accessories until the actuator is ready for installation at the site.

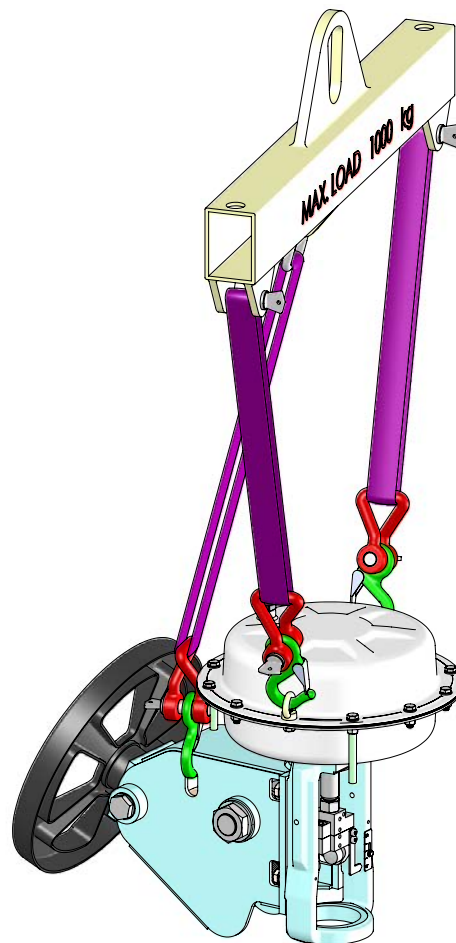

Figure 4: Triple-Leg Sling (Example)

9 Installation

The actuator must be installed and commissioned by qualified staff - personnel who are familiar with the installation, commissioning and operation of this product and possess the relevant qualifications in their field of activity.

! Prior to installation of the actuator, we require, that you check the following conditions to reduce the risk of malfunction and safety related incidents.

No.	Check	Possible malfunction or safety related incident
1	Confirm that the nominal / operational data on the serial plate matches the operational data of the facility.	An operational mismatch can cause considerable damage to the actuator or may lead to a failure at the facility.

Table 1: Basic safety messages for installing the actuator (continued on next page 6)

No.	Check	Possible malfunction or safety related incident
2	Confirm that the ambient temperature is not elevated permanent above 160 °F (70 °C)(unless restricted by the accessories).	<i>A sustained exceeding of the permissible ambient temperature of 18 °F (10 °C) may halves the lifetime of non-metallic components, such as diaphragms, O-rings and scraper rings.</i>
3	Confirm that the air supply and instrument signal lines are dry and clear of dirt and oil.	<i>At a minimum, the instrument air must conform to ISA- 7.0.01-1996 (ISO 8573-1 Compressed Air - Class 2) requirement or those of the accessory manufacturer.</i>
4	Confirm that the actuator and valve can be installed in an upright position.	<i>Non-upright positioning may result in premature wear.</i>
5	Confirm that the yoke and needed parts are available for mounting on the valve.	<i>Yoke - connection dimensions see page 7</i>
6	Confirm that the valve stem and connecting parts match.	<i>Yoke - connection dimensions see page 7.</i>
7	Confirm the actuator has enough overhead clearance to disassemble the valve from the pipeline.	<i>Minimum clearance zone see page 8</i>
8	If there is an unused air connection ensure that it is properly sealed (see page 7).	<i>The venting chamber of the pneumatic actuator is always equipped with a venting plug. The pneumatic actuator types 253, 503 and 701 have two air connectors joining the pressure-tight actuator housing. One of this air connectors is used to control the actuator depending on the mounted accessories. The remaining connector on the actuator (S) or on the yoke (T) must be appropriately sealed. This feature is not applicable for type 1502 and 3002.</i>
9	Confirm removal of all hazards and ensure appropriate protective measures are in place.	<i>none</i>
10	Confirm the valve / actuator is grounded in order to prevent an electrical discharge.	<i>Noncompliance may result in electrical discharges.</i>
11	Throttling control valves are typically equipped with a pneumatic actuator and valve positioner. Refer to the appropriate positioner manual for connections and maximum air supplies.	<i>The air supply must be limited to less than 87 psig (6 bar) per the actuator serial plate. An air filter regulator should be installed to ensure that the supply pressure to the pneumatic actuator does not exceed the air supply pressure indicated on the serial plate.</i>

Table 1: Basic safety messages for installing the actuator

Yoke - connection dimensions (mm)

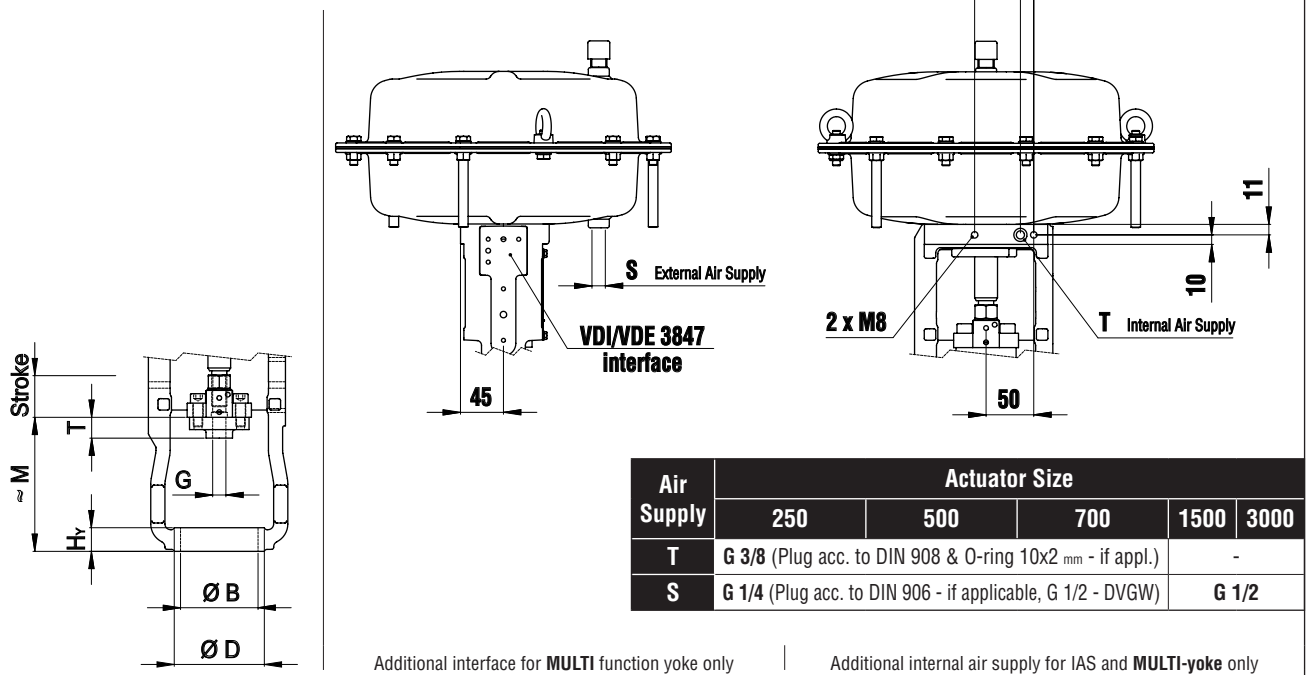

Air Supply	Actuator Size				
	250	500	700	1500	3000
T	G 3/8 (Plug acc. to DIN 908 & O-ring 10x2 mm - if appl.)				-
S	G 1/4 (Plug acc. to DIN 906 - if applicable, G 1/2 - DVGW)				G 1/2

Additional interface for MULTI function yoke only

Additional internal air supply for IAS and MULTI-yoke only

Yoke dimensions		IAS-Yoke for						MULTI-Yoke for						NAMUR-Yoke for											
		Valtek GS						FlowTop, Valtek CS						FlowTop				FlowPro ¹⁾ , VariCool							
Size	Stroke	Ø B	~ M	G	T	Ø D	H _V	Ø B	~ M	G	T	Ø D	H _V	Ø B	~ M	G	T	Ø D	H _V	Ø B	~ M	G	T	Ø D	H _V
250	10	-						65	110	M12	23	95	20	-											
	20	49	106	M12	18	75	20	65	105	M12	23	95	20	65	105	M12	12	95	20	82	150	M16	16	115	25
500	20	49	144	M12	54	75	20	65	105	M12	23	115	20	65	105	M12	16	95	20	82	150	M16	16	115	25
		65	145	M16	59	90	20	82	140	M16	25	115	25	82	140	M16	16	115	25	82	140	M20	20	115	25
700	20	49	144	M12	54	75	20	65	105	M12	23	115	20	65	105	M12	16	95	20	82	150	M16	16	115	25
		65	145	M16	59	90	20	82	140	M16	25	115	25	82	140	M16	16	115	25	82	140	M20	20	115	25
	40	82	140	M20	22	110	25	82	140	M16	25	115	25	82	140	M16	16	115	25	82	140	M20	20	115	25
1500	20	49	144	M12	54	75	20	65	105	M12	23	115	20	65	105	M12	16	95	20	82	150	M16	16	115	25
		65	145	M16	59	90	20	82	140	M16	25	115	25	82	140	M16	16	115	25	82	140	M20	20	115	25
		82	140	M20	22	110	25	82	140	M16	25	115	25	82	140	M16	16	115	25	82	140	M20	20	115	25
		82	148	M20	34	110	25	82	140	M16	25	115	25	82	150	M20	20	125	25	82	150	M16	20	110	20
		82	140	M16	29	105	25	82	140	M16	29	105	25	82	140	M16	29	105	25	82	140	M20	29	105	25
		82	150	M20	29	105	25	82	140	M16	29	105	25	82	140	M20	29	105	25	82	140	M20	29	105	25
3000	40	82	140	M12	29	105	25	82	140	M16	29	105	25	82	140	M16	29	105	25	82	140	M20	29	105	25
		82	150	M20	29	105	25	82	140	M16	29	105	25	82	140	M20	29	105	25	82	140	M20	29	105	25
		82	140	M20	29	105	25	82	140	M16	29	105	25	82	140	M20	29	105	25	82	140	M20	29	105	25
		82	140	M20	29	105	25	82	140	M16	29	105	25	82	140	M20	29	105	25	82	140	M20	29	105	25

¹⁾ ATTENTION: FlowPro with Nominal Size DN 25 or 1", Stroke 20 mm:
 Packing Design -> adjustable -> Ø B = 65 mm, M = 105 mm, G = M12, Ø D = 95 mm and H_V = 20 mm only !
 Packing Design -> spring loadet -> Ø B = 82 mm, M = 170 mm, G = M12 only !

Table 2: Basic safety messages for installing the actuator

Minimum Clearance Zone

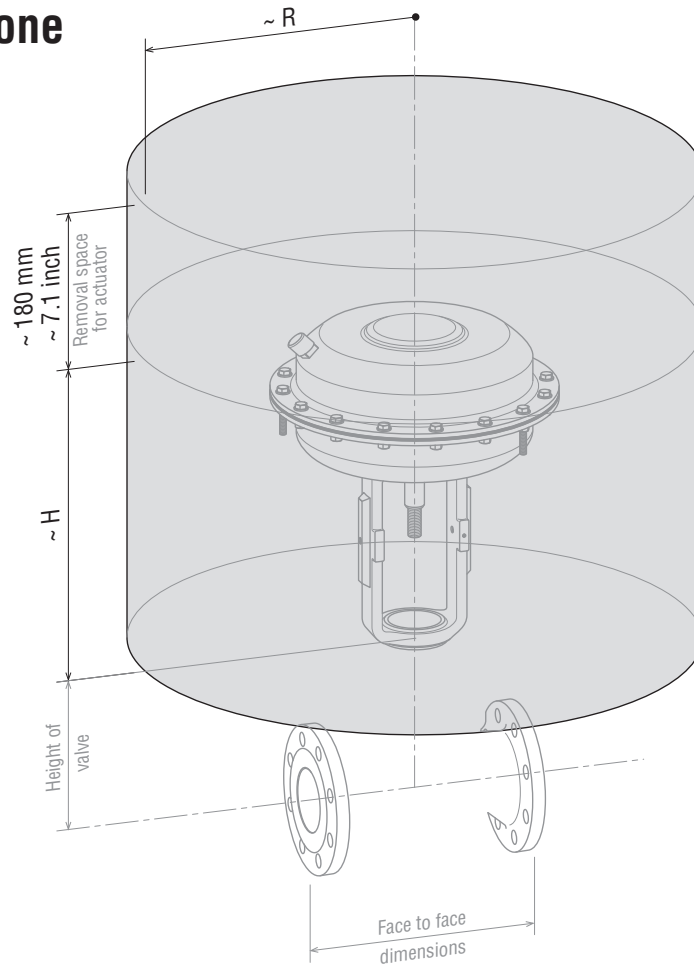

Figure 5: Overhead clearance drawing

Actuator Size		~ R				~ H max	
		without accessories	accessories direct mounted	accessories NAMUR - mounted	with side mounted hand wheel	without hand wheel	with top mounted hand wheel
250	mm	135	195	290	-	335	595
500	mm	180	195	330	-	460	870
700	mm	205	205	345	-	600	925
1500	mm	275	-	415	685	800	-
3000	mm	275	-	415	685	1140	-

Table 3: Overhead clearance dimensions / drawing

10 Assembly on valve

The FlowAct diaphragm linear actuator is allowed to be assembled and reassembled only by qualified staff - personnel who are familiar with assembling, reassembling, installation and commissioning of this product, and possess the relevant qualifications in their field of activity.

8 When performing repairs, personnel are to follow these in-

structions using only **original** equipment manufacturer (OEM) spare parts and recommended special tools to ensure the reliability of the FlowAct diaphragm linear actuator.

Only Flowserve trained and authorized personnel are allowed to repair (disassemble and reassemble) the FlowAct in hazardous areas.

Actuators for oil and grease-less service or oxygen service may only be disassembled and reassembled in clean rooms (ISO 14644- ISO 8, US FED STD 209 E - M 6.5, or equivalent).

WARNING Diaphragm linear actuators are pressure vessels. Improper opening of the actuator can result in bodily injury.

Actuator assembly procedure

1. Fix the valve on the assembly table.

NOTICE The orientation of the valve must be in accordance with the appropriate mounting position !

2. Lubricate all threads with a suitable, approved lubricant (see Section 16).
3. Mount the actuator / yoke and yoke lock nut (76) onto the valve bonnet.
4. Finger tighten and fix the yoke lock nut; turn clockwise (see Section 15).

NOTICE The legs of the yoke should be parallel to the flow direction !

5. If the fail safe position at air failure moves the stem into closing position then must the actuator connected with the air supply to move the stem into the open (retracted) position (in most cases).

WARNING Due to risk of crushing hazard, do not work between the yoke legs while the valve is in operation.

6. Mount the lock nut (113) and lower coupling (345) onto the valve stem.
7. Justify the plug against the seat.
8. Adjust the distance between the lower coupling (345) and the upper coupling (249) with the aid of an adapter in stroke height (Figure 7).
9. Disconnect the air supply so that the actuator moves to the close position.
10. Mount the cap screws (240).
11. Lock the lock nut (113). Secure the upper coupling (249) against turn unwanted with a wrench.
12. Adjust the stroke indicator scale so that the zero mark is in conjunction with the stroke indicator.
13. Perform three full strokes and check if the stroke indicator scale correspond with the end positions.

14. The valve is ready for the mounting of the accessories.

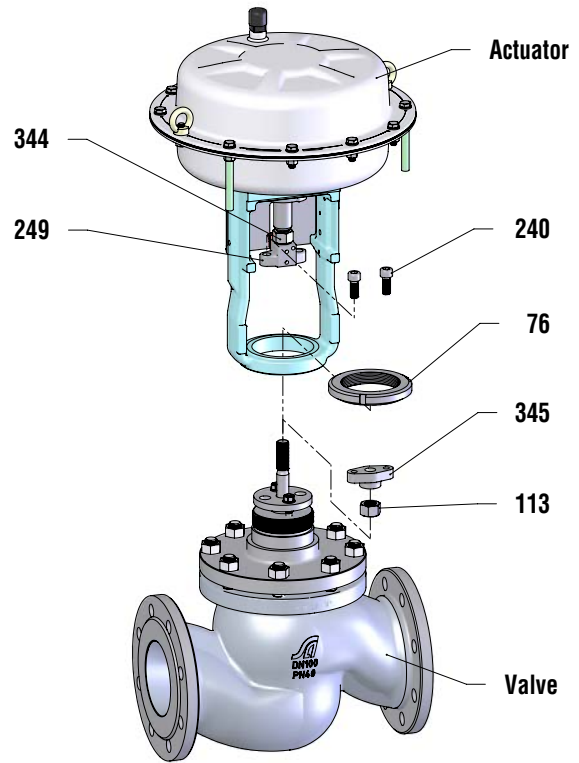

Figure 6: Yoke assembly drawing

Item		Part	Item		Part
WW	EU		WW	EU	
76	5.10	Yoke lock nut	249	5.3	Upper coupling
113	5.2	Lock nut	344	5.4	Lock nut
240	5.5	Cap screw	345	5.1	Lower coupling

Table 4: Coupling parts identification

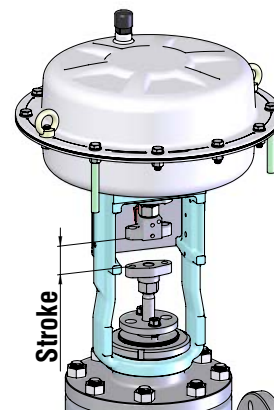

Figure 7: Stroke adjusting

Reassemble the valve into the pipe

1. Remove the protective flange covers and coating from the control valve; clean the flange gasket surface.

NOTICE *Unsuitable cleaning agents can damage and cause leakage in PTFE and graphite gaskets. Review a current chemical resistance list before applying.*

2. Install the valve so that the actuator is in an upright position whenever possible. Vertical installation permits easier actuator maintenance.
3. Install and connect the control valve to the pipeline. Locate gaskets in the center of the body flanges and secure nuts and bolts.
4. Connect the air supply and instrument signal lines.

11 Valve Quick-Check

Apply appropriate personal protective equipment when working on the control valve to prevent hazards arising from the operation. Protect yourself against freezing, burns and cuts by wearing appropriate protective clothing, gloves and eye protection.

Do not over-tighten packing.

Sudden exposure of the control valve to full working pressure and temperature may cause stress cracks.

Prior to valve operation, we require, that you check the following conditions to reduce the risk of malfunction and safety related incidents.

No.	Important information	Possible malfunction or safety related incident
1	Avoid critical operating conditions where excessive noise or vibration levels might occur.	<i>Impermissible continuous operation of a control valve under critical conditions can damage the valve.</i>
2	Avoid frequent system start-ups and shutdowns.	<i>Critical operating conditions, which can damage the control valve, may be encountered during system start-up or shut down.</i>
3	Keep the operating medium free of foreign particles.	<i>Installing a suitable strainer upstream of the control valve can prevent foreign particles from damaging the valve.</i>
4	Instrument air must conform to ISA 7.0.01-1996 (with a dew point at least 18 °F (10 °C) below ambient temperature, particle size below 1 µm and oil content not to exceed 1 ppm)	<i>Contaminated instrument air can damage the accessories and diaphragm linear actuator or cause them to fail.</i>
5	Do not touch the body and bonnet ! The temperature of the operating medium is transferred to the surface of the linear actuator.	Excessive hot surface temperatures can put you at risk for burns. Frigid surface temperatures can put you at risk for freezing.
6	Critical operating conditions can cause excessive or hazardous levels of vibration or noise.	Impermissible levels of vibration can cause hearing loss, vascular and nerve damage and damage to joints and bones. Use hearing protection when noise levels exceed 80 dB(A).
7	Incorrect maintenance can result in the emission of hot, cryogenic, and / or toxic operating media.	Incorrect maintenance can put you at risk for heat related burns, freezing, acid burns or poisoning.

WARNING Due to risk of crushing hazard, do not work between the yoke legs while the valve is in operation.

Prior to start-up, we strongly recommend that you:

1. Stroke the valve and compare the plug position indicator on the stem clamp to the stroke indicator plate. The plug should change position in a smooth, linear fashion.

NOTICE Graphite packing commonly creates more friction than other materials, such as PTFE. If over tightened, excessive friction may impair smooth control.

2. Adjust instrument signals to ensure a full stroke.

3. Check the packing box bolting to ensure the correct adjustment.

NOTICE Over tightening can cause excessive packing wear and high stem friction that may impede plug movement.

4. Continuously increase load until operation parameters are reached.
5. Minor relaxation of the flange bolting is possible after initial assembly. Retorque the bonnet flange bolting if necessary before installation or following an initial temperature excursion to ensure the bonnet gaskets do not leak.

(See User Instructions - Control Valve).

12 Actuator Maintenance

Maintenance intervals and service life of an actuator is unique to local environmental conditions at the site. The intervals specified in the User Instructions are recommendations and serve only as a guide. Under difficult operating conditions, maintenance may be more frequent. We strongly recom-

mend a site survey followed by a documented procedure for performing the maintenance work. Maintenance personnel should perform and log the work accordingly. The data collected can be used as a basis for dynamically determining the maintenance intervals and activities.

Recommended Maintenance Actions					
No.	Service	Inter-val	Valve Condition		
			Good	Adequate	Inadequate
1	Visual inspection of the actuator	Bi-weekly	No action	Clean actuator stem with a soft cloth	Repair or replace actuator according to product life cycle
2	Visual inspection of the tightness	Bi-weekly	No action	Retighten leaky air supply, case bolting	Replace leaky air supply, diaphragm, O-ring immediately
	Preventive maintenance of the diaphragm	→	Dependent upon results of previous maintenance (see numbers 1 and 2 above) or a minimum of once every 10 years		
3	Visual inspection of case bolting	Yearly	No action	Retighten case bolting if diaphragm leaks.	Remove from service and replace case bolting, diaphragm immediately if external leakage persists or if bolting is damaged
4	Operation test	→	No action	Perform 3 full strokes using air supply; check for leakage	

Recommended maintenance actions using the Logix digital positioner with ValveSight diagnostic solution software					
5	Visual inspection of diagnostic interface	Weekly	No action - valve is healthy	Take action per warning	Overhaul or replace required part per alarm
6	Check health parameter of actuator	Warning	No action - actuator is healthy	Check and retighten air supply	Overhaul or replace actuator after alarm
7	Check health parameter of positioner	Warning	No action - positioner is healthy	Start step test	Overhaul or replace positioner after alarm

Table 6: Service activities check list

! Prior to valve maintenance it is required that you check the following conditions to reduce the risk of malfunction and safety related incidents.

No.	Check	Possible malfunction or safety related incident
1	Check for signs of leakage through the case bolting and end flanges.	<i>Tighten the case bolting nuts. See Section 14: Disassembly and Reassembly for instructions. Also see Section 15.</i>
2	Check if all nuts and bolts are securely fastened.	! Avoid critical operating conditions if excess noise or vibration levels occur during operation.
3	Check valve for smooth, full-stroke operation. Unsteady stem movement could indicate an internal valve problem.	<i>Internal valve failure requires an immediate overhaul or actuator replacement by qualified staff.</i>

Table 7: Basic safety messages for maintenance the valve

! **WARNING** **Crushing hazard ! Failure to keep hands, hair, and clothing away from all moving parts when operating the control valve can cause serious injury.**

1. Clear all dirt and / or foreign material from the shaft and control valve.
2. If leakage is detected, retighten the bolting.
3. Activities on the valve, see separate document.
4. Make sure all nuts and bolts are securely fastened.
5. If possible, stroke the valve and check for smooth, full-stroke operation. Unsteady stem movement could indicate an internal valve problem.

6. Make sure all accessory brackets and bolting are securely fastened.

7. Check control valve health parameters:

- Characteristic curves of the valve with flow
- Upstream pressure
- Downstream pressure

into the control room.

NOTICE *Monitor trim and bonnet components. If nominal and actual values differ by more than 5%, maintenance may be required.*

13 Troubleshooting

Contact customer service department or contract partner for any fault or defect found, otherwise the manufacturer’s guarantee shall be rendered null and void and the manufacturer released from any responsibility. If the user performs the repairs, these User Instructions must be adhered to and carried out in a competent manner. Original Equipment Manufacturer spare parts must be used to make the repair.

Defect	No.	Possible Causes	Remedy
Stem does not move	1.1	• No energy supply (pneumatic air) to actuator and accessories (positioner, air filter regulator, solenoid valve, limit switch, and/ or special accessories)	• Pneumatic actuators: Check supply for leaks Check air pressure (usually 6 bar; 88 psig)
	1.2	• Mounted accessories do not work	• See User Instructions for accessory manufacturer
	1.3	• Pneumatic actuator is defective	• Contact customer service department or contract partner

Defect	No.	Possible Causes	Remedy
Jerky stem movement	2.1	• Damaged stem	• Contact customer service department or contract partner
	2.2	• Actuator not powerful enough	• Compare actuator specifications on the serial plate with operation specifications of the facility. If incompatible, contact customer service department or contract partner
Stem travel less than full stroke (0 to 100 %)	3.1	• Air supply pressure too low	• Provide air at the pressure stated on the serial plate (European production only).
	3.2	• Pneumatic actuators: Improper handwheel position	• Move handwheel to limit position , otherwise contact factory for information.
	3.3	• Improperly adjusted or defective positioner	• Readjust positioner to positioner manufacturer's specification
	3.4	• Foreign particles in valve seat or damaged trim	• Contact customer service department or contract partner
No limit switch signal	4.1	• Power supply to limit switch interrupted	• Check power supply (connections, circuit breakers, voltage)
	4.2	• Limit switch out of adjustment	• Readjust limit switch operating distance; see limit switch data sheet
Unstable positioner	5.1	• Defective positioner	• See user instruction of the positioner manufacturer

Table 8: Trouble-shooting

14 Operation of the handwheel

⚠ WARNING Due to risk of crushing hazard, do not work with the handwheel during regular operation. Actuation is only permitted with separated air supply !

1. The handwheel is always in the neutral position in the delivery condition.
2. The handwheel are designed to act against the fail safety position of the actuator. That means in the case of an pneumatic actuator design with restoring springs.

NOTICE When adjusting, then the handwheel press against the spring force - without the actuator the handwheel has no function.

3. All handwheel designs are immediately ready for use, except the lateral handwheel for the 1502 and 3002 actuator. In the event of fail safe position - spring-to-open (retracted) - before using, the handwheel must turned counterclockwise up to contact the drive pin in the coupling and subsequently locked.
4. Check the progress of the stroke adjustment on the stroke indicator scale.
5. If normal operation is to be resumed, the handwheel must be turned always to the neutral position.

15 Disassembly and Reassembly

The FlowAct linear actuator is allowed to be disassembled and reassembled only by qualified staff - personnel who are familiar with disassembling, reassembling, installation and commissioning of this product, and possess the relevant qualifications in their field of activity.

When performing repairs, personnel are to follow these instructions using only **original** equipment manufacturer (OEM) spare parts and recommended special tools to ensure the reliability of the FlowAct linear actuator.

Only Flowserve trained and authorized personnel are allowed

to repair (disassemble and reassemble) the FlowAct in hazard areas.

Actuators and valves for oil and grease-less service or oxygen service only be disassembled and reassembled in clean rooms (ISO 14644- ISO 8, US FED STD 209 E - M 6.5, or equivalent).

! WARNING Pneumatic actuator are pressure vessels. Improper opening of the actuator can result in bodily injury.

! Prior to disassemble and reassemble, we require, that you check the following conditions to reduce the risk of malfunction and safety related incidents.

No.	Important information	Possible malfunction or safety related incident
1	Disregarding these instructions may bring serious or harmful consequences.	<i>Failure to comply with these user instructions will render the manufacturer's guarantee and liability null and void. Unless otherwise agreed, the manufacturer's general terms and conditions of sale shall apply.</i>
2	! Always observe system safety instructions when preparing for and performing the repair procedure.	Potential hazards and their sources are under the operator's influence. The operator must observe national and international environmental regulations for control valve removal from the pipe and cleaning. Permissible exposure limits must be maintained, appropriate personal protective equipment must be used and service personnel must be properly instructed in performing the repair procedure.
3	! Make sure the pipeline is depressurized an ambient state, also a suitable rigging (e.g. Endless Sling) and securing devices (e.g. Vee Trough with Stands / Vise) are readily available.	Remove the valve / actuator from the pipeline in a depressurized and ambient state. Failure to do so can cause serious personal injury. The control valve is not equipped with integral stands, therefore guard against the valve from tipping over. Bodily injuries can be the result. Use appropriate clamps, blocking or other stabilizing support. Attachment to overhead crane can ensure stability.
4	Confirm that you have the required spare parts at the site.	<i>Not having the full complement of parts, accessories and tools can slow or stop repair work.</i>
5	! Confirm that you have the required tools available to manage the disassembly and reassembly (Special Tools on request !).	Improper tools and / or improper use of tools can result in personal injury or damage to the parts.
6	Review the serial plate information to identify the actuator. The serial number and the part numbers needed are required when ordering spare parts.	<i>A serial plate used for product identification is attached on every valve / actuator (See Section 3: Product Identification).</i>
7	Check all parts for damage such as scoring, deformities, corrosion or overexpansion.	<i>If in doubt, replace faulty parts. Never reuse gaskets.</i>

Table 9: Basic safety messages for repairing the actuator

After these requirements are confirmed the pneumatic actuator can be maintained and repaired.

Disassemble the actuator from the valve:

WARNING Actuators are pressure vessels. Improper opening of the actuator can result in bodily injury.

1. Disconnect the air supply from the actuator and / or assembled accessories.
2. Disassemble the accessories from the actuator as necessary.
3. If is mounted a handwheel-side disassemble this first (see pages 37 - 38).
4. Realize the fail safe position of the actuator. The coupling parts must be free of positioning force.

WARNING Crushing hazard ! The actuator stem is under spring load. Never disconnect the air supply during next steps, the stem will extends very quickly.

- If the actuator stem is extended, drive it into retracted position by connecting air supply.
 - If the actuator stem is retracted no further action is required.
 - If the valve type is a three way valve drive the stem into center position by connecting and control air supply.
5. Keep upper coupling (249) from turning by secure with a wrench. Turn the lock nut (113) clockwise to loosen.
 6. Turn the cap screws (240) counterclockwise to loosen.
 7. Turn the yoke lock nut (76) counterclockwise to loosen.
 8. Disconnect the air supply from the actuator if applicable.
 9. Lift off the actuator safely.
 10. Place the actuator on an assembly table and fix the yoke for disassembly.

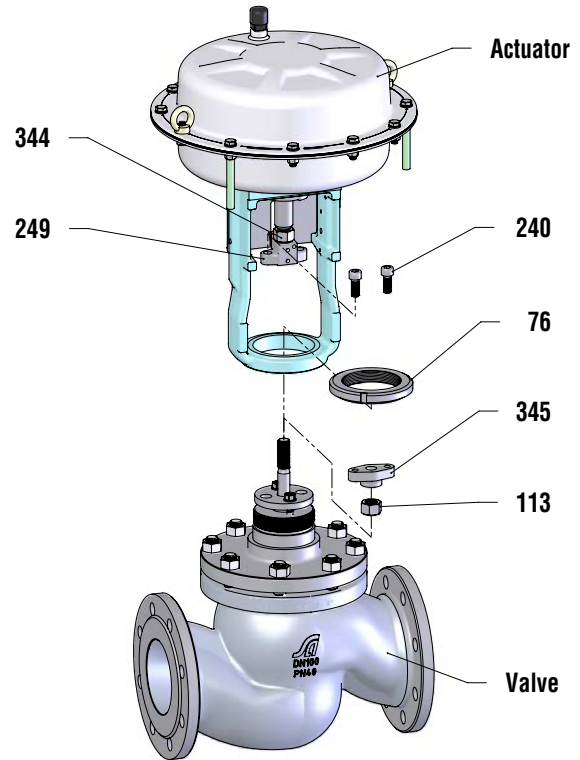

Figure 8: Yoke assembly drawing

Item		Part	Item		Part
WW	EU		WW	EU	
76	5.10	Yoke lock nut	249	5.3	Upper coupling
113	5.2	Lock nut	344	5.4	Lock nut
240	5.5	Cap screw	345	5.1	Lower coupling

Table 10: Coupling parts identification

The modular design of the actuators enables a wide variety of variants. Following therefore is always described the individual module and not the entire actuator. We ask for your understanding.

Reassemble the Actuator onto the valve:

1. Mount the actuator onto the bonnet and tighten the yoke lock nut (76) clockwise.

NOTICE *The legs of the yoke should be parallel to the flow direction.*

2. Move the actuator to the open position.
3. Screw in the lock nut (113) onto the valve stem so it is screwed all the way and lower coupling (345) three turns and move the actuator into the closed position.

NOTICE *The plug must be aligned onto the seat. The cushioning effect of the bellows can be prevented by tightening the packing follower.*

4. Move the actuator back into the open position and adjust the distance between the lower coupling (345) and upper coupling (249) by adjusting the stroke length.

Valve size		Stroke	
15 - 25	1/2" - 1"	10 +0.5 mm	0.394 +0.02 in.
15 - 50	1/2" - 2"	20 +0.5 mm	0.787 +0.02 in.
65 - 100	3" - 4"	40 +0.5 mm	1.574 +0.02 in.
125 - 150	6"	60 +0.8 mm	2.362 +0.03 in.
200 - 300 ¹⁾	8" - 12" ¹⁾	80 +0.8 mm	3.150 +0.03 in.
400	16"	100 +0.8 mm	3.937 +0.03 in.

Table 11: Stroke adjustment length (¹⁾ depends on the valve series)

5. Move the actuator to the close position and install the cap screws (240).
6. Lock the lock nut (113). Keep upper coupling (249) from turning by securing with a wrench.
7. If a handwheel-side was mounted reassemble as next (see pages 37 - 38).

NOTICE *The handwheel-side always presses on the coupling, depending on the safety position when actuated. The lever arms must be positioned so that this condition is given.*

8. Place the handwheel-side on the yoke and straighten it, mount the washer (140) and hex bolt (150) and tighten it, if applicable.

9. Check handwheel-side for correct limit position, if applicable.
10. Reassemble the accessory on the valve as necessary, see relevant accessory User Instruction.
11. Perform three full strokes and check the free movement of the actuator.
12. For installation the valve into the pipeline and further steps see User Instructions for applicable valve types.
13. Log the maintenance interval and the work performed.

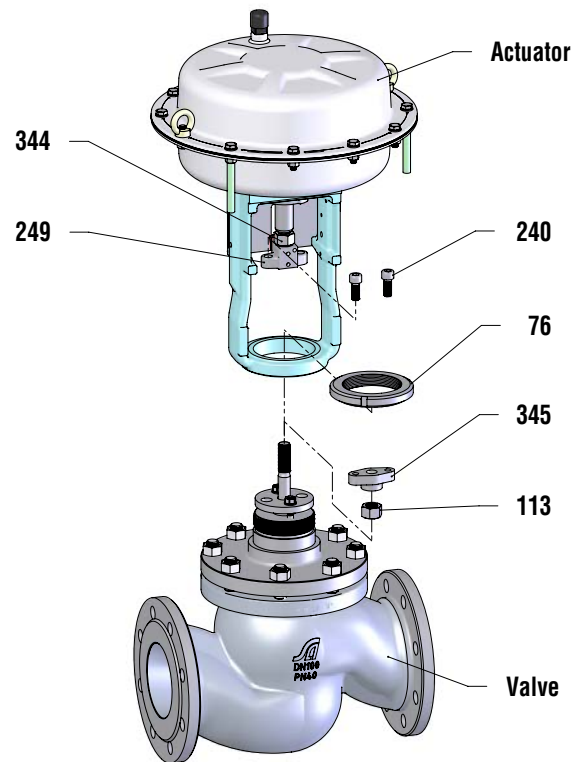

Figure 9: Yoke assembly drawing



Item		Part	Item		Part
WW	EU		WW	EU	
76	5.10	Yoke lock nut	249	5.3	Upper coupling
113	5.2	Lock nut	344	5.4	Lock nut
240	5.5	Cap screw	345	5.1	Lower coupling

Table 12: Coupling parts identification

Pneumatic Actuator - Type 253, 503, 701

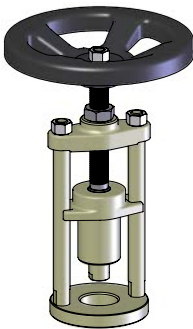
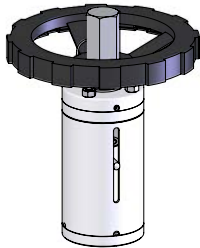
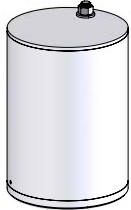
- Type 1502 see page 39
- Type 3002 see page 57

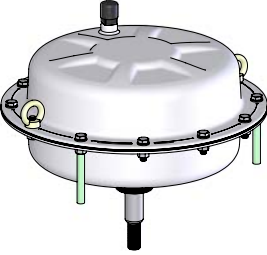
Attachments		
Handwheel		Stroke Limitation
light-duty	heavy-duty	adjustable limit stop
		
see pages 26 - 27	see pages 28 - 31	see pages 32 - 33

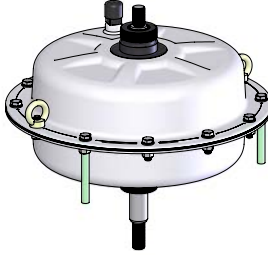
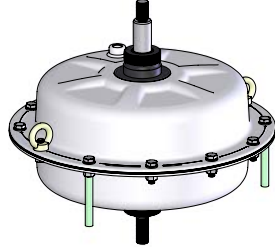
Actuator without attachments		Actuator with attachments	
Spring-to-close	Spring-to-open	Spring-to-close	Spring-to-open
			
see pages 18 - 19	see pages 20 - 21	see pages 22 - 23	see pages 24 - 25

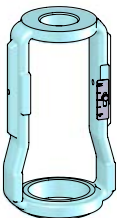
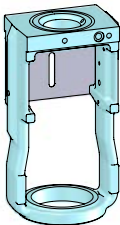
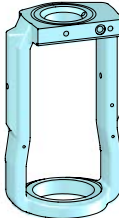
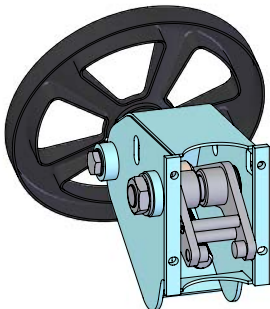
Cast yoke design acc. to IEC 60534-6-1			Handwheel
NAMUR-yoke, with double mounting pads	MULTI-yoke, with pad and interface for direct positioner and sole- noid valve mounting	IAS-yoke, with double pads and in- terface for direct positioner mounting	side-mounted for IAS-yoke only
			
see page 34	see page 35	see page 36	see pages 37 - 38

Actuator without attachments

Spring-to-close

Disassembly instruction of the actuator subassembly

NOTICE *Limit disassembly only to necessary components.*

1. Fix the actuator on the assembly table, if this is not already happened.
2. Loosen the lock nut (344) counterclockwise and disassemble the upper coupling (249) and lock nut clockwise (see page 15).
3. Disassemble the short hexagon bolts (335), plain washers (337), hexagon nuts (351) and ring nuts (209).
4. Pull off the protection sleeve (339).

⚠ WARNING **Risk of injury by jumping out parts ! Pre-loaded springs inside.**

5. Lubricate the threads and loosen the long hexagon bolts (336), plain washers (337) and hexagon nuts (351) uniformly in a clockwise sequence as the springs expand.

NOTICE *We recommend using threaded bolts meeting standards from ISO 898-1, 8.8 or higher, as well as washers and nuts.*

6. Lift off the diaphragm casing (203), distance plate (231) and spring adjusting plate (326).
7. Remove the actuator springs (229).
8. Carefully remove the diaphragm-stem unit (211 - 349).
9. Remove the scraper ring (273) and O-ring (275).
10. Secure the diaphragm-stem unit into the Special Tool.
11. Loosen the special nut (348) counterclockwise and remove the lock washer (349), spacer bushing (228), diaphragm plate (227), diaphragm (225), O-ring (272) and thrust washer (255).
12. Check stressed surface areas for damage such as scoring and deformities. Use a brass brush or similar tool to clean bolting. Check for corrosion or any other damage.

Reassembly instruction of the actuator subassembly

NOTICE *Always replace parts showing wear with new parts.*

13. Lubricate the new O-ring (275), new scraper ring (273) with an appropriate lubricant and install into the guide bushing (253).
14. Lubricate the new O-ring (272) with an appropriate lubricant.
15. Lower the thrust washer (255), diaphragm (225), O-ring (272), diaphragm plate (227), spacer bushing (228), lock washer (349) onto the stem (211).
16. Lubricate the thread of the stem (211) with an appropriate lubricant and install and finger tighten the special nut (348).

NOTICE *The diaphragm plate should be positioned to the diaphragm with the aid of the Positioning Template. Mark the position.*

17. Turn the special nut (348) clockwise using a suitable torque wrench.
18. Loosen and remove the diaphragm-stem unit (211-349) from the Special Tool. Lubricate the actuator stem with an appropriate lubricant.
19. Carefully lower the diaphragm-stem unit (211-349) into the diaphragm casing.

NOTICE *Position the diaphragm-stem unit such that the air connection and the Mark align.*

20. Install and align the actuator springs (229).
21. Install and positioning the spring adjusting plate (326) such that the drilling, mark and air connection match.
22. Install the distance plate (231) and diaphragm casing (203), positioning the casing such that the drilling, mark and air connections match.
23. Lubricate the threads of the long hexagon bolts (336) with an appropriate lubricant then compress the springs

uniformly in a clockwise sequence by tightening the long hexagon bolts (336), plain washers (337) and hexagon nuts (351). Alternative method see *NOTICE* step 5.

- 24. Install the short hexagon bolts (335), hexagon nuts (351) as well as the hexagon bolts (335) and ring nuts (209).
- 25. Tighten the nuts (351) using a crosswise pattern in four steps.
- 26. Install the protection sleeve (339).
- 27. Reassemble the yoke and coupling parts, perform three full strokes then check the tightening of the casing bolting.

- 28. Log the maintenance interval and the work performed.
- 29. The actuator subassembly is ready to be mounted on the valve and the accessories attached.

Item #		Part
WW	EU	
202	6.1	Diaphragm Casing
203	6.2	Diaphragm Casing
209	6.6	Ring Nut
211	6.12	Stem
225	6.16	Diaphragm
227	6.15	Diaphragm Plate
228	6.13	Spacer Bushing
229	6.21	Actuator Spring
231	6.22	Distance Plate
253	6.8	Guide Bushing
254	6.80	Plain Bearing
255	6.18	Thrust Washer
258	6.26	Vent Plug
272	6.17	O-Ring
273	6.11	Scraper Ring
275	6.10	O-Ring
326	6.23	Spring Adjusting Plate
335	6.3.1	Hexagon Bolt - short
336	6.3.2	Hexagon Bolt - long
337	6.5	Plain Washer
339	6.25	Protection Sleeve
348	6.20	Special Nut
349	6.19	Lock Washer
351	6.4	Hexagon Nut

Table 13: Actuator parts

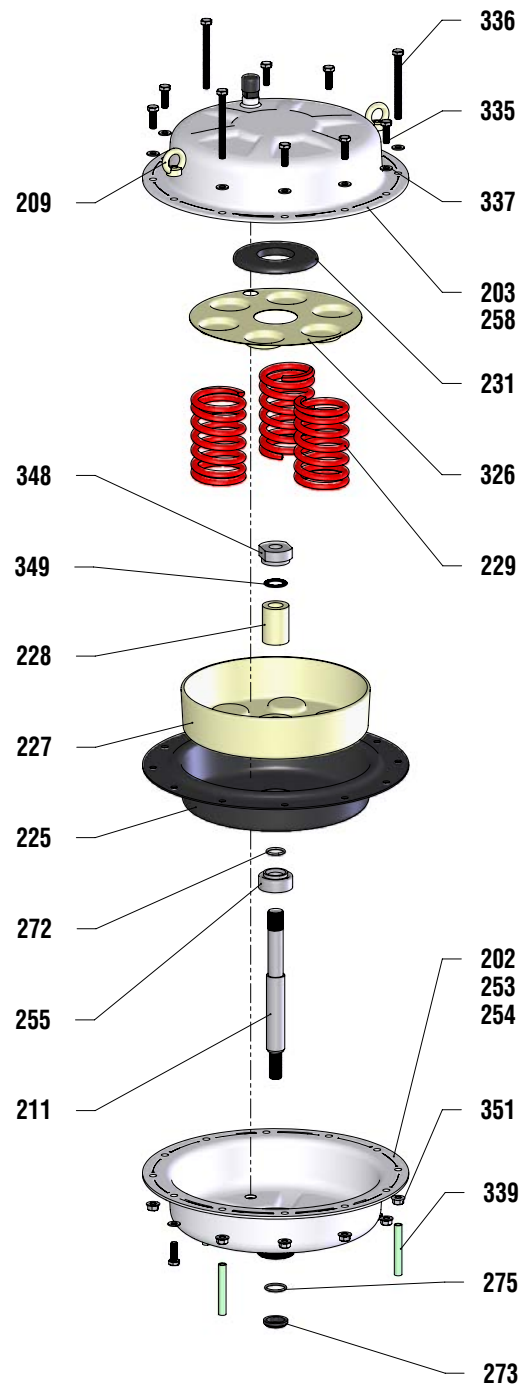

Figure 10: Actuator parts

Actuator without attachments

Spring-to-open

Disassembly instruction of the actuator subassembly

NOTICE *Limit disassembly only to necessary components.*

1. Fix the actuator on the assembly table, if this is not already happened.
2. Loosen the lock nut (344) counterclockwise and disassemble the upper coupling (249) and lock nut clockwise (see page 15).
3. Disassemble the hexagon bolts (335), plain washers (337), hexagon nuts (351) and ring nuts (209).
4. Pull off the protection sleeve (339).

⚠ WARNING **Risk of injury by jumping out parts ! Pre-loaded springs inside.**

5. Lubricate the threads and loosen the long hexagon bolts (336), plain washers (337) and hexagon nuts (351) uniformly in a clockwise sequence as the springs expand.

NOTICE *We recommend using threaded bolts meeting standards from ISO 898-1, 8.8 or higher, as well as washers and nuts.*

6. Lift off the diaphragm casing (203).
7. Carefully remove the diaphragm-stem unit (211 - 349).
8. Remove the actuator springs (229).
9. Remove the spring adjusting plate (326).
10. Remove the scraper ring (273) and O-ring (275).
11. Secure the diaphragm-stem unit into the Special Tool.
12. Loosen the special nut (348) counterclockwise and remove the lock washer (349), thrust washer (255), O-ring (272), diaphragm (225), diaphragm plate (227), and spacer bushing (228).
13. Check stressed surface areas for damage such as scoring and deformities. Use a brass brush or similar tool to clean bolting. Check for corrosion or any other damage.

Reassembly instruction of the actuator subassembly

NOTICE *Always replace parts showing wear with new parts.*

14. Lubricate the new O-ring (275), new scraper ring (273) with an appropriate lubricant and install into the guide bushing (253).
15. Lubricate the new O-ring (272) with an appropriate lubricant.
16. Lower the spacer bushing (228), diaphragm plate (227), diaphragm (225), O-ring (272), thrust washer (255), lock washer (349) onto the stem (211).
17. Lubricate the thread of the stem (211) with an appropriate lubricant and install and finger tighten the special nut (348).
18. Turn the special nut (348) clockwise using a suitable torque wrench.
19. Loosen and remove the diaphragm-stem unit (211-349) from the Special Tool. Lubricate the actuator stem with an appropriate lubricant.
20. Install and positioning the spring adjusting plate (326) such that the drilling and air connection match.
21. Install and align the actuator springs (229).
22. Carefully lower the diaphragm-stem unit (211- 349) into the diaphragm casing.
23. Install the diaphragm casing (203), positioning the casing such that the air connections are aligned.
24. Lubricate the threads of the long hexagon bolts (336) with an appropriate lubricant then compress the springs uniformly in a clockwise sequence by tightening the long hexagon bolts (336), plain washers (337) and hexagon nuts (351). Alternative method *see NOTICE* step 5.
25. Install the short hexagon bolts (335), hexagon nuts (351) as well as the hexagon bolts (335) and ring nuts (209).
26. Tighten the nuts (351) using a crosswise pattern in four steps.

27. Install the protection sleeve (339).
28. Reassemble the yoke and coupling parts, perform three full strokes then check the tightening of the casing bolting.
29. Log the maintenance interval and the work performed.
30. The actuator subassembly is ready to be mounted on the valve and the accessories attached.

Item #		Part
WW	EU	
202	6.1	Diaphragm Casing
203	6.2	Diaphragm Casing
209	6.6	Ring Nut
211	6.12	Stem
225	6.16	Diaphragm
227	6.15	Diaphragm Plate
228	6.13	Spacer Bushing
229	6.21	Actuator Spring
253	6.8	Guide Bushing
254	6.80	Plain Bearing
255	6.18	Thrust Washer
258	6.26	Vent Plug
272	6.17	O-Ring
273	6.11	Scraper Ring
275	6.10	O-Ring
326	6.23	Spring Adjusting Plate
335	6.3.1	Hexagon Bolt - short
336	6.3.2	Hexagon Bolt - long
337	6.5	Plain Washer
339	6.25	Protection Sleeve
348	6.20	Special Nut
349	6.19	Lock Washer
351	6.4	Hexagon Nut

Table 14: Actuator parts

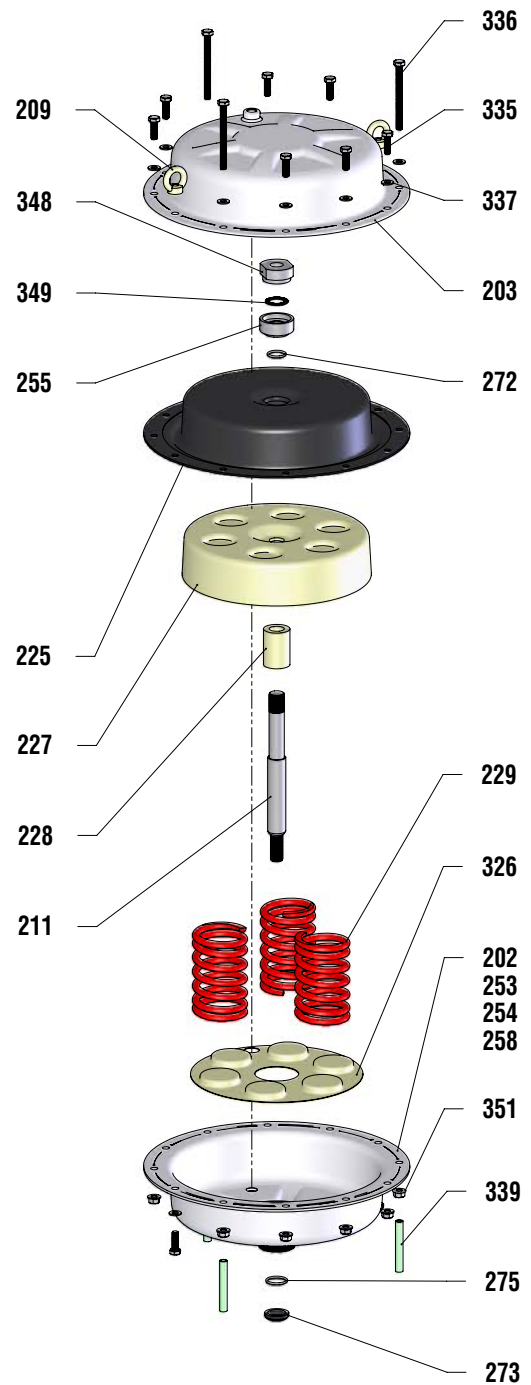

Figure 11: Actuator parts

Actuator with attachments

Spring-to-close

Disassembly instruction of the actuator subassembly

NOTICE Limit disassembly only to necessary components.

1. Fix the actuator on the assembly table, if this is not already happened.
2. Disassemble the attachments first (see page 16).
3. Loosen the lock nut (344) clockwise and disassemble the upper coupling (249) and lock nut (see page 15).
4. Disassemble the hexagon bolts (335), plain washers (337), hexagon nuts (351) and ring nuts (209).
5. Pull off the protection sleeve (339).

WARNING Risk of injury by jumping out parts ! Pre-loaded springs inside.

6. Lubricate the threads and loosen the long hexagon bolts (336), plain washers (337) and hexagon nuts (351) uniformly in a clockwise sequence as the springs expand.

NOTICE We recommend using threaded bolts meeting standards from ISO 898-1, 8.8 or higher, as well as washers and nuts.

7. Lift off the diaphragm casing (203) and spring adjusting plate (326).
8. Remove the actuator springs (229).
9. Carefully remove the diaphragm-stem unit (211 - 349).
10. Remove the scraper rings (273) and O-rings (275).
11. Secure the diaphragm-stem unit into the Special Tool.
12. Loosen the special stem (348) counterclockwise and remove the lock washer (349), spacer bushing (228), diaphragm plate (227), diaphragm (225), O-ring (272) and thrust washer (255).
13. Check stressed surface areas for damage such as scoring and deformities. Use a brass brush or similar tool to clean bolting. Check for corrosion or any other damage.

Reassembly instruction of the actuator subassembly

NOTICE Always replace parts showing wear with new parts.

14. Lubricate the new O-rings (275), new scraper rings (273) with an appropriate lubricant and install into the guide bushing (253 and 390).
15. Lubricate the new O-ring (272) with an appropriate lubricant.
16. Lower the thrust washer (255), diaphragm (225), O-ring (272), diaphragm plate (227), spacer bushing (228), lock washer (349) onto the stem (211).
17. Lubricate the thread of the stem (211) with an appropriate lubricant and install and finger tighten the special stem (348).

NOTICE The diaphragm plate should be positioned to the diaphragm with the aid of the Positioning Template. Mark the position.

18. Turn clockwise the special stem (348) using a suitable torque wrench.
19. Loosen and remove the diaphragm-stem unit (211 - 349) from the Special Tool. Lubricate the actuator stems with an appropriate lubricant.
20. Carefully lower the diaphragm-stem unit (211 - 349) into the diaphragm casing.

NOTICE Position the diaphragm-stem unit such that the air connection and the Mark align.

21. Install and align the actuator springs (229).
22. Install and positioning the spring adjusting plate (326) such that the drilling, mark and air connection match.
23. Install the diaphragm casing (203), positioning the casing such that the drilling, mark and air connections match.
24. Lubricate the threads of the long hexagon bolts (336) with an appropriate lubricant and load the springs uniformly in a clockwise sequence by tightening the long hexagon bolts (336), plain washers (337) and hexagon nuts (351). Alternative method see *NOTICE* step 6.

- 25. Install the short hexagon bolts (335), hexagon nuts (351) as well as the hexagon bolts (335) and ring nuts (209).
- 26. Tighten the nuts (351) using a crosswise pattern in four steps.
- 27. Install the protection sleeve (339).
- 28. Reassemble the yoke and coupling parts, perform three full strokes then check the tightening of the casing bolting.

- 29. Log the maintenance interval and the work performed.
- 30. The actuator subassembly is ready for the reassemble of the attachments - see page 16 - and accessories.

Item #		Part
WW	EU	
202	6.1	Diaphragm Casing
203	6.2	Diaphragm Casing
209	6.6	Ring Nut
211	6.12	Stem
225	6.16	Diaphragm
227	6.15	Diaphragm Plate
228	6.13	Spacer Bushing
229	6.21	Actuator Spring
231	6.22	Distance Plate
253	6.8	Guide Bushing
254	6.80	Plain Bearing (2x)
255	6.18	Thrust Washer
258	6.26	Vent Plug
272	6.17	O-Ring
273	6.11	Scraper Ring (2x)
275	6.10	O-Ring (2x)
276	6.9	O-Ring
326	6.23	Spring Adjusting Plate
335	6.3.1	Hexagon Bolt - short
336	6.3.2	Hexagon Bolt - long
337	6.5	Plain Washer
339	6.25	Protection Sleeve
348	6.29	Stem
349	6.19	Lock Washer
351	6.4	Hexagon Nut
390	6.24	Guide Bushing

Table 15: Actuator parts

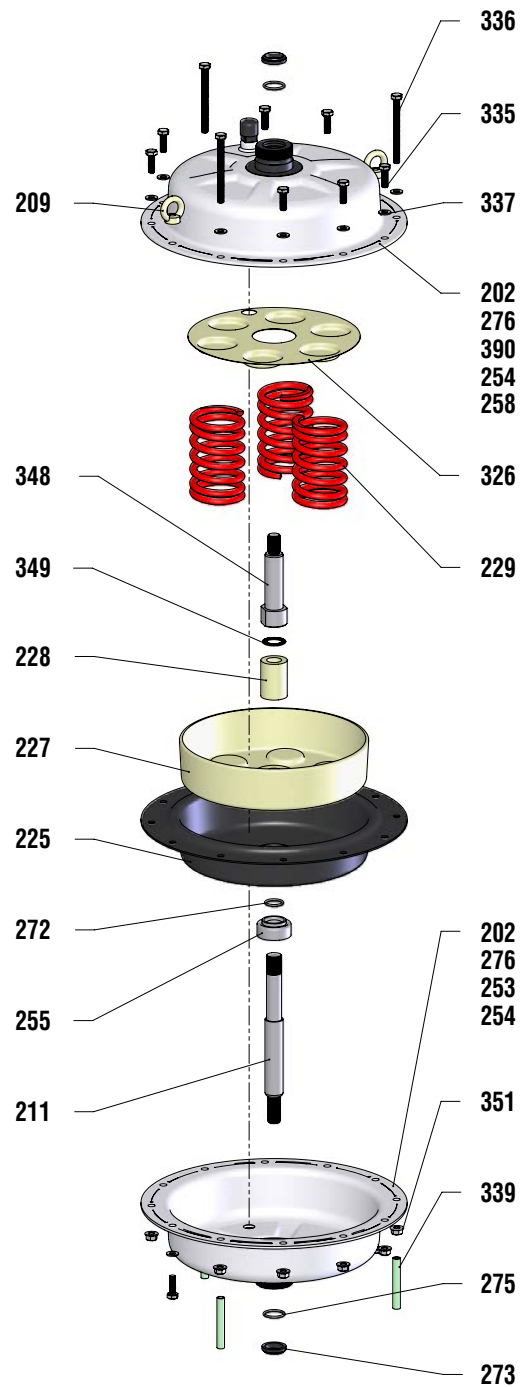

Figure 12: Actuator parts

Actuator with attachments

Spring-to-open

Disassembly instruction of the actuator subassembly

NOTICE *Limit disassembly only to necessary components.*

1. Fix the actuator on the assembly table, if this is not already happened.
2. Disassemble the attachments first (see page 16).
3. Loosen the lock nut (344) clockwise and disassemble the upper coupling (249) and lock nut (see page 15).
4. Disassemble the hexagon bolts (335), plain washers (337), hexagon nuts (351) and ring nuts (209).
5. Pull off the protection sleeve (339).

 **WARNING** **Risk of injury by jumping out parts ! Pre-loaded springs inside.**

6. Lubricate the threads and loosen the long hexagon bolts (336), plain washers (337) and hexagon nuts (351) uniformly in a clockwise sequence as the springs expand.

NOTICE *We recommend using threaded bolts meeting standards from ISO 898-1, 8.8 or higher, as well as washers and nuts.*

7. Lift off the diaphragm casing (203).
8. Carefully remove the diaphragm-stem unit (211 - 349).
9. Remove the actuator springs (229).
10. Remove the spring adjusting plate (326).
11. Remove the scraper rings (273) and O-rings (275).
12. Secure the diaphragm-stem unit into the Special Tool.
13. Loosen the special stem (348) counterclockwise and remove the lock washer (349), thrust washer (255), O-ring (272), diaphragm (225), diaphragm plate (227), and spacer bushing (228).
14. Check stressed surface areas for damage such as scoring and deformities. Use a brass brush or similar tool to clean bolting. Check for corrosion or any other damage.

Reassembly instruction of the actuator subassembly

NOTICE *Always replace parts showing wear with new parts.*

15. Lubricate the new O-rings (275), new scraper rings (273) with an appropriate lubricant and install into the guide bushing (253 and 390).
16. Lubricate the new O-ring (272) with an appropriate lubricant.
17. Lower the spacer bushing (228), diaphragm plate (227), diaphragm (225), O-ring (272), thrust washer (255), lock washer (349) onto the stem (211).
18. Lubricate the thread of the stem (211) with an appropriate lubricant and install and finger tighten the special stem (348).
19. Turn clockwise the special stem (348) using a suitable torque wrench.
20. Loosen and remove the diaphragm-stem unit (211 - 349) from the Special Tool. Lubricate the actuator stems with an appropriate lubricant.
21. Install and positioning the spring adjusting plate (326) such that the drilling and air connection match.
22. Install and align the actuator springs (229).
23. Carefully lower the diaphragm-stem unit (211 - 349) into the diaphragm casing.
24. Install the diaphragm casing (203), positioning the casing such that the air connections are aligned.
25. Lubricate the threads of the long hexagon bolts (336) with an appropriate lubricant and load the springs uniformly in a clockwise sequence by tightening the long hexagon bolts (336), plain washers (337) and hexagon nuts (351). Alternative method see *NOTICE* step 6.
26. Install the short hexagon bolts (335), hexagon nuts (351) as well as the hexagon bolts (335) and ring nuts (209).
27. Tighten the nuts (351) using a crosswise pattern in four steps.

28. Install the protection sleeve (339).
29. Reassemble the yoke and coupling parts, perform three full strokes then check the tightening of the casing bolting.
30. Log the maintenance interval and the work performed.
31. The actuator subassembly is ready for the reassemble of the attachments - see page 16 - and accessories.

Item #		Part
WW	EU	
202	6.1	Diaphragm Casing
209	6.6	Ring Nut
211	6.12	Stem
225	6.16	Diaphragm
227	6.15	Diaphragm Plate
228	6.13	Spacer Bushing
229	6.21	Actuator Spring
253	6.8	Guide Bushing
254	6.80	Plain Bearing (2x)
255	6.18	Thrust Washer
258	6.26	Vent Plug
272	6.17	O-Ring
273	6.11	Scraper Ring (2x)
275	6.10	O-Ring (2x)
276	6.9	O-Ring
326	6.23	Spring Adjusting Plate
335	6.3.1	Hexagon Bolt - short
336	6.3.2	Hexagon Bolt - long
337	6.5	Plain Washer
339	6.25	Protection Sleeve
348	6.29	Stem
349	6.19	Lock Washer
351	6.4	Hexagon Nut
390	6.24	Guide Bushing

Table 16: Actuator parts

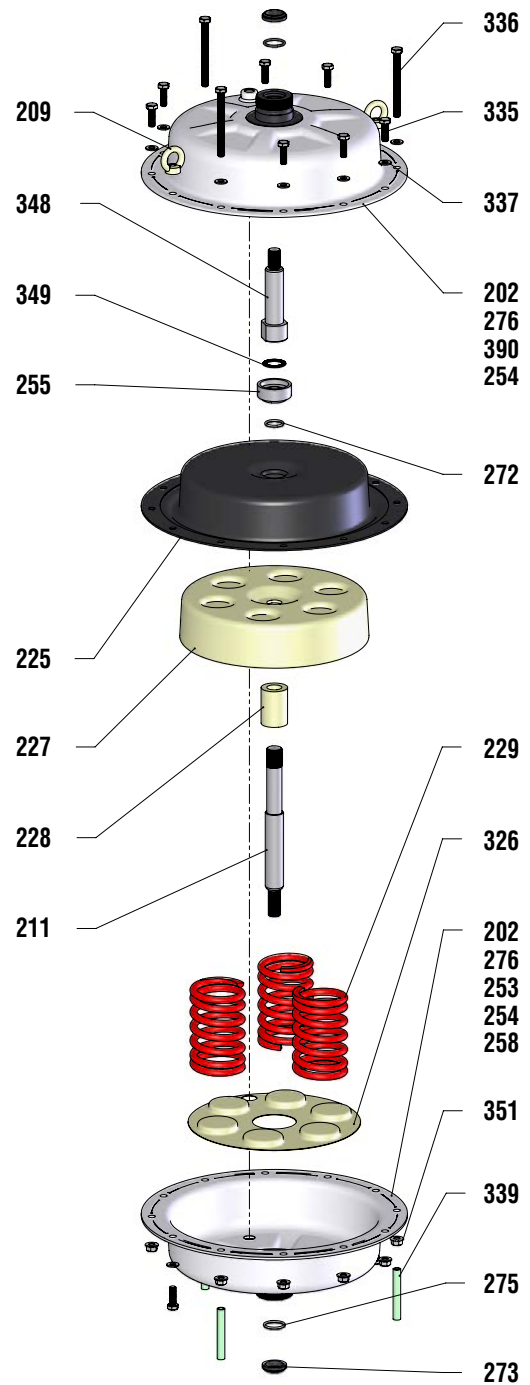

Figure 13: Actuator parts

Actuator with Handwheel - light

Spring-to-close

Disassembly instruction of the handwheel subassembly

NOTICE Limit disassembly only to necessary components.

1. Fix the actuator on the assembly table, if this is not already happened.
2. Loosen the hexagon nut (372) clockwise.
3. Loosen the carrier (394) counter-clockwise.
4. Loosen the lock nut (256) counter-clockwise.

NOTICE Use a rounded chisel and a hammer.

5. Lift off and store the handwheel safely, lose no parts.
6. For disassemble the actuator subassembly see pages 22 - 23.

Reassembly instruction of the handwheel subassembly

7. Lubricate the threads of the actuator with an appropriate lubricant.
8. Mount the handwheel onto the actuator and tighten the

lock nut (256) clockwise.

NOTICE Use a rounded chisel and a hammer.

9. Mount the hexagon nut (372) onto the actuator stem.
10. Mount the carrier (394) clockwise and lock the hexagon nut (372).
11. Connect the actuator with the air supply, perform three full strokes and check the free movement of the carrier.

NOTICE The carrier must be able to move freely without hitting in the end-positions.

12. Log the maintenance interval and the work performed.
13. The actuator subassembly is ready to be mounted on the valve and the accessories attached.

Item #		Part
WW	EU	
256	5.11	Lock Nut
372	6.30	Hex Nut
394	6.31	Carrier

Table 17: Handwheel parts

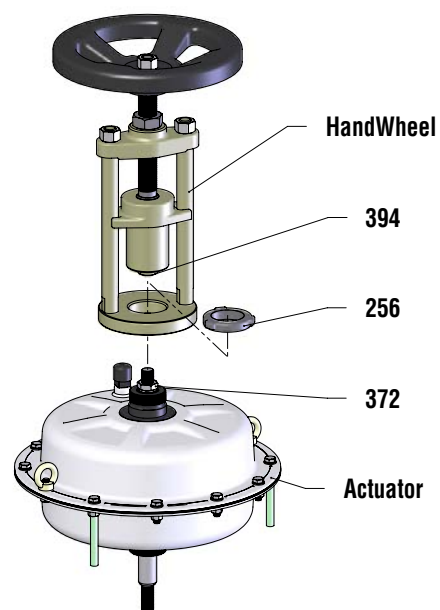

Figure 14: Handwheel parts

Actuator with Handwheel - light

Spring-to-open

Disassembly instruction of the handwheel subassembly

NOTICE Limit disassembly only to necessary components.

1. Fix the actuator on the assembly table, if this is not already happened.
2. Turn the handwheel counter-clockwise as long as it reached the upper end-position.
3. Loosen the hexagon nut (372) clockwise.
4. Loosen the carrier (394) counter-clockwise.
5. Loosen the lock nut (256) counter-clockwise.

NOTICE Use a rounded chisel and a hammer.

6. Lift off and store the handwheel safely, lose no parts.
7. For disassemble the actuator subassembly see pages 24 - 25.

Reassembly instruction of the handwheel subassembly

8. Lubricate the threads of the actuator with an appropriate lubricant.
9. Mount the handwheel onto the actuator and tighten the lock nut (256) clockwise.

NOTICE Use a rounded chisel and a hammer.

10. Mount the hexagon nut (372) onto the actuator stem.
11. Mount the carrier (394) clockwise and lock the hexagon nut (372).
12. Turn the handwheel clockwise as long as it reached the upper end-position.
13. Connect the actuator with the air supply, perform three full strokes and check the free movement of the carrier.

NOTICE The carrier must be able to move freely without hitting in the end positions.

14. Log the maintenance interval and the work performed.
15. The actuator subassembly is ready to be mounted on the valve and the accessories attached.

Item #		Part
WW	EU	
256	5.11	Lock Nut
372	6.30	Hex Nut
394	6.31	Carrier

Table 18: Handwheel parts

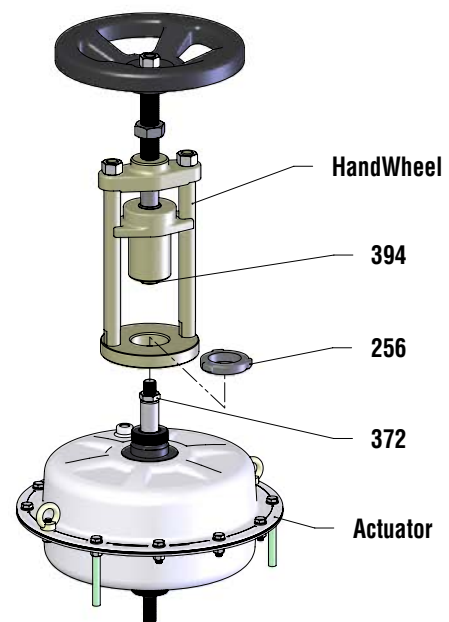

Figure 15: Handwheel parts

Actuator with Handwheel - heavy

Spring-to-close or -open

Disassembly instruction of the handwheel subassembly

NOTICE *Limit disassembly only to necessary components.*

1. Fix the actuator on the assembly table, if this is not already happened.
2. Loosen the hex nuts (333) counter-clockwise.
3. Unlock the handwheel.
4. Turn the handwheel counter-clockwise until the assembly (329 - 393) is lifted off.
5. Remove the flange (389) and pipe section (387).
6. Unlock the hex nut (6.30) clockwise.
7. Turn the threaded pin (331) counter-clockwise to loosen and remove stem-assembly (331 - 399) from the actuator stem.
8. Turn the stud bolts (397) counter-clockwise.
9. Mark the position of the flange (390) to the actuator.
10. Loosen the lock nut (256) counter-clockwise.

NOTICE *Use a rounded chisel and a hammer.*

11. Lift off the hex nut (372) and flange (390).
12. Store all handwheel-parts safely, lose no parts.
13. For disassemble the actuator subassembly see pages 24 - 25.

Reassembly instruction of the handwheel subassembly

NOTICE *Always replace parts showing wear with new parts.*

14. Lubricate the threads of the actuator and handwheel-parts with an appropriate lubricant.
15. Place the flange (390) onto the actuator and put in line with the mark.
16. Mount and tighten the lock nut (256) clockwise.

NOTICE *Use a rounded chisel and a hammer.*

17. Mount the hexagon nut (372) onto the actuator stem so it is screwed all the way.
18. Mount and finger tighten the stud bolts (397) clockwise.
19. Place the stem-assembly (331 - 399) onto the actuator stem and mount the threaded pin (331) clockwise (screw-in depth once thread diameter). The positioning indicator should point forward.
20. Lock the hex nut (372) counter-clockwise.
21. Carefully thump and thread the pipe section (387) onto the flange (390).
22. Place the flange (389) onto the pipe section (387).
23. Place the handwheel-assembly (329 - 393) onto the flange (389), lift the stem-assembly (331 - 399) and turn up the handwheel to screw one into another. The grease nipple should point forward.
24. Mount the hex nuts (333) and finger-tighten.
25. Turn the handwheel clockwise as long as it reached the upper end-position.
26. Connect the actuator with the air supply, perform three full strokes and check the free movement of the threaded pin.
27. Lock the handwheel with the locking pin (332).

NOTICE *The threaded pin must be able to move freely without hitting in the end positions.*

28. Log the maintenance interval and the work performed.

29. The actuator subassembly is ready to be mounted on the valve and the accessories attached.

Item #		Part
WW	EU	
256	5.11	Lock Nut
329	6.73	O-Ring
330	6.72	Key Ring
331	6.62	Threaded Pin
332	6.70	Locking Pin
333	6.41	Hex Nut (4x)
340	6.68	O-Ring
341	6.67	O-Ring
342	6.71	Knotted Chain
365	6.63	Impact Grease Nipple
366	6.59	Compression Ring
367	6.61	Position Indicator
370	6.60	Parallel Key
372	6.30	Hex Nut
373	6.32	Bushing
375	6.33	Thrust Ball Bearing
380	6.36	Stem
381	6.66	Closure Screw
387	6.55	Pipe Section
388	6.57	Bearing Flange
389	6.40	Flange - top
390	6.38	Flange - bottom
391	6.58	Threaded Bushing
393	6.42	Handwheel
397	6.56	Stud Bolt (4x)
399	6.34	Threaded Ring

Table 19: Handwheel parts

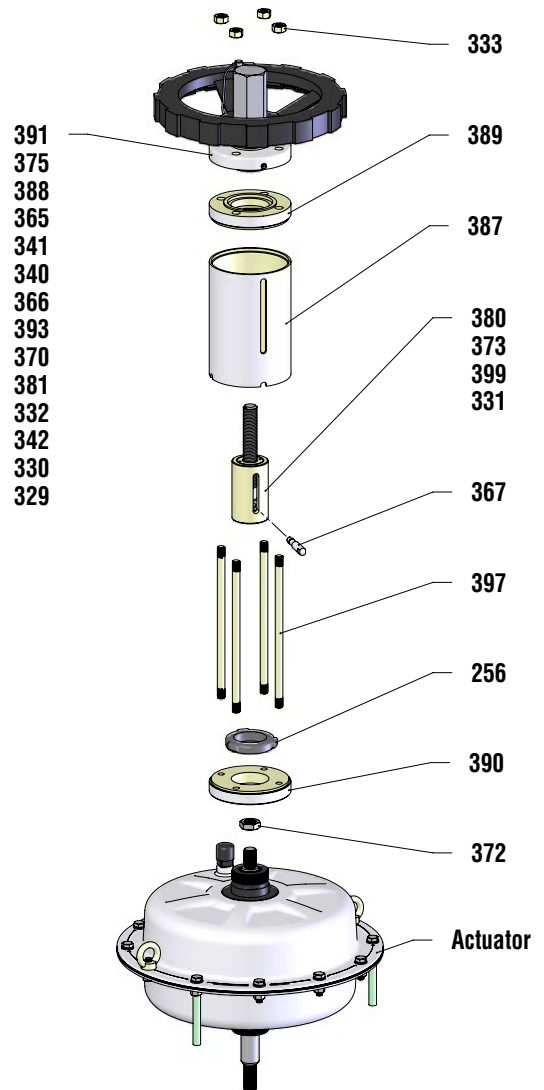

Figure 16: Handwheel parts

Actuator with Handwheel - heavy

> Offshore - Design < Spring-to-close or -open

Disassembly instruction of the handwheel subassembly

NOTICE *Limit disassembly only to necessary components.*

1. Fix the actuator on the assembly table, if this is not already happened.
2. Loosen the hex nuts (333) counter-clockwise.
3. Unlock the handwheel.
4. Turn the handwheel counter-clockwise until the assembly (266 - 393) is lifted off.
5. Remove the O-rings (264, 265), flange (389, 263) and pipe section (387).
6. Unlock the hex nut (372) clockwise.
7. Turn the threaded pin (331) counter-clockwise to loosen and remove stem-assembly (331 - 399) from the actuator stem.
8. Turn the stud bolts (397) counter-clockwise.
9. Mark the position of the flange (390) to the actuator.
10. Loosen the lock nut (256) counter-clockwise.

NOTICE *Use a rounded chisel and a hammer.*

11. Lift off the hex nut (372), flange (390) and O-ring (262).
12. Store all handwheel-parts safely, lose no parts.
13. For disassemble the actuator subassembly see pages 24 - 25.

Reassembly instruction of the handwheel subassembly

NOTICE *Always replace parts showing wear with new parts.*

14. Lubricate the threads of the actuator and handwheel-parts with an appropriate lubricant.
15. Place the flange (390) onto the actuator and put in line with the mark.
16. Mount and tighten the lock nut (256) clockwise.

NOTICE *Use a rounded chisel and a hammer.*

17. Mount the hexagon nut (372) onto the actuator stem so it is screwed all the way.
18. Mount and finger tighten the stud bolts (397) clockwise.
19. Place the stem-assembly (331 - 399) onto the actuator stem and mount the threaded pin (331) clockwise (screw-in depth once thread diameter). The positioning indicator should point half left.
20. Lock the hex nut (372) counter-clockwise.
21. Carefully thump and the pipe section (387) onto the flange (390).
22. Place the flange (389) onto the pipe section (387) also the O-rings (264, 265).
23. Carefully place the handwheel-assembly (391 - 329) onto the flange (389), lift the stem-assembly (331 - 399) and turn up the handwheel to screw one into another. The grease nipple should point forward.
24. Mount the hex nuts (333) and finger-thigten.
25. Turn the handwheel clockwise as long as it reached the upper end-position.
26. Connect the actuator with the air supply, perform three full strokes and check the free movement of the threaded pin.

NOTICE *The threaded pin must be able to move freely without hitting in the end positions.*

27. Lock the handwheel with the locking pin (332).

28. Log the maintenance interval and the work performed.

29. The actuator subassembly is ready to be mounted on the valve and the accessories attached.

Item #		Part
WW	EU	
256	5.11	Lock Nut
262	6.74	O-Ring
263	6.75	O-Ring (2x)
264	6.76	O-Ring
265	6.77	O-Ring (4x)
266	6.78	O-Ring
267	6.79	Scraper Ring
329	6.73	O-Ring
330	6.72	Key Ring
331	6.62	Threaded Pin
332	6.70	Locking Pin
333	6.41	Hex Nut (4x)
340	6.68	O-Ring
341	6.67	O-Ring
342	6.71	Knotted Chain
365	6.63	Impact Grease Nipple
366	6.59	Compression Ring
367	6.61	Rotation lock
370	6.60	Parallel Key
372	6.30	Hex Nut
373	6.32	Bushing
375	6.33	Thrust Ball Bearing
380	6.36	Stem
381	6.66	Closure Screw
386	6.69	Position Indicator
387	6.55	Pipe Section
388	6.57	Bearing Flange
389	6.40	Flange - top
390	6.38	Flange - bottom
391	6.58	Threaded Bushing
393	6.42	Handwheel
397	6.56	Stud Bolt (4x)
399	6.34	Threaded Ring

Table 20: Handwheel parts

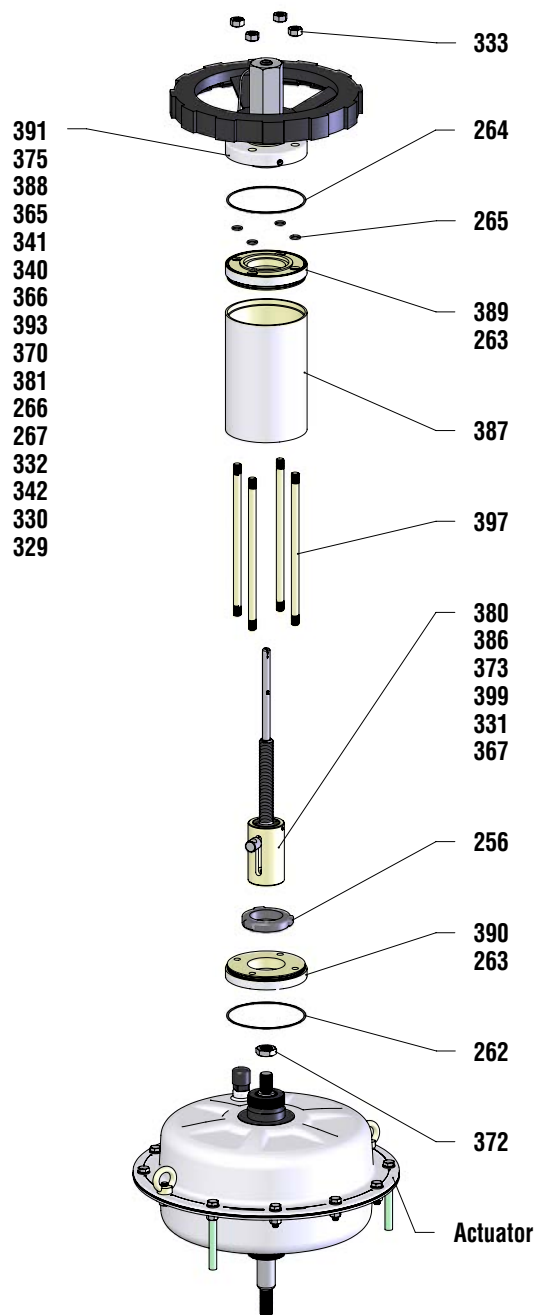

Figure 17: Handwheel parts

Actuator with Stroke Limitation

Spring-to-close or -open

Disassembly instruction of the stroke limitation subassembly

NOTICE Limit disassembly only to necessary components.

1. Fix the actuator on the assembly table, if this is not already happened.
2. Loosen the hex nut (379) counter-clockwise.
3. Remove the plain washer (376), cover (381) and the pipe section (387).
4. Unlock the lock nuts (350, 2x) counter-clockwise.
5. Loosen the lock nut (256) counter-clockwise.

NOTICE Use a rounded chisel and a hammer.

6. Lift off the stroke limitation assembly (333 - 389).
7. Unlock the lock nuts (350, 2x) counter-clockwise.
8. Store all stroke limitation-parts safely, lose no parts.
9. For disassemble the actuator subassembly see pages 24 - 25.

Reassembly instruction of the stroke limitation subassembly

10. Lubricate the threads of the actuator and stroke limitation-parts with an appropriate lubricant.
11. Mount the lock nuts (350, 2x) clockwise.
12. Place the stroke limitation assembly (333 - 389) and the lock nut (256) onto the actuator.
13. Mount and tighten the lock nut (256) clockwise.

NOTICE Use a rounded chisel and a hammer.

14. Mount the lock nuts (350, 2x) clockwise.
15. Connect the actuator with the air supply. Control the air supply until the desired upper and lower stroke position is approached. Position the lock nuts (350) at the end positions and secure them.
16. Place the pipe section (387) onto the flange (389).
17. Place the flange (381) onto the pipe section (387).
18. Mount the washer (376) and hex nuts (379) and finger tighten.
19. Reassemble the yoke and coupling parts, perform three full strokes then check on the stroke indicator whether the desired positions are achieved.
20. Log the maintenance interval and the work performed.
21. The actuator subassembly is ready to be mounted on the valve and the accessories attached.

Item #		Part
WW	EU	
256	5.11	Lock Nut
333	6.108	Socket Head Screw (3x)
334	6.107	Plain Washer (3x)
350	6.109	Lock Nut (4x)
376	6.112	Plain Washer
377	6.103	Yoke Rod (3x)
378	6.106	Yoke Plate
379	6.113	Hex Nut
380	6.101	Stem
381	6.111	Cover
384	6.104	Hexagon Nut
385	6.105	Stud Bolt
387	6.110	Pipe Section
389	6.102	Flange

Table 21: Stroke limitation parts

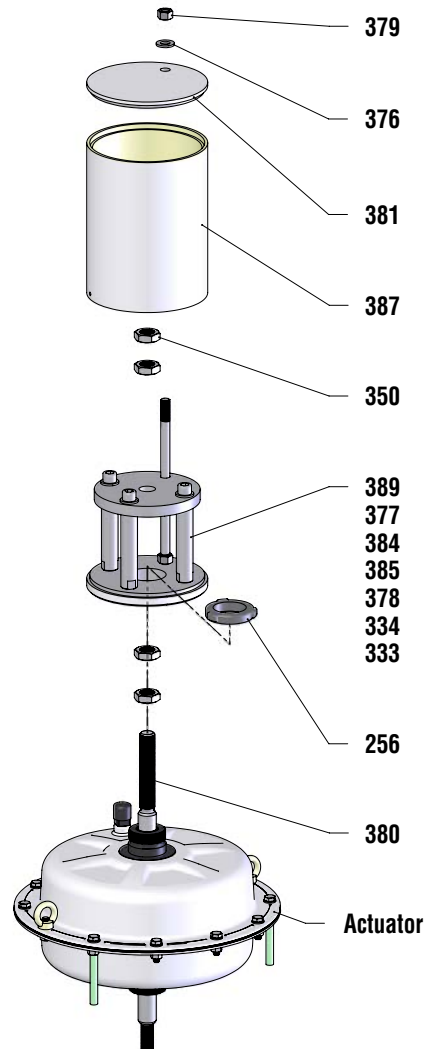

Figure 18: Stroke limitation parts

Actuator with NAMUR-yoke

Spring-to-close or -open

Disassembly instruction of the yoke

NOTICE Limit disassembly only to necessary components.

1. Fix the actuator on the assembly table, if this is not already happened (see also pages 14 - 15).
2. The hex bolt (420) and stroke scale (213) can remain on the yoke.
3. Unlock the lock nut (344) counter-clockwise.
4. Loosen the actuator coupling (249) and lock nut (344) clockwise.
5. We recommend you not to remove the actuator from the yoke. If this is indispensable mark the position, loosen the actuator locknut (256) clockwise and lift off the actuator.

NOTICE Use a rounded chisel and a hammer.

6. Store all coupling and yoke-parts safely, lose no parts.
7. For disassemble the attachments see pages 26 - 33 and for actuator subassembly see pages 18 - 25.

Reassembly instruction of the yoke

8. Lubricate the threads of the actuator and stroke coupling-parts with an appropriate lubricant.
9. If necessary mount the actuator onto the yoke (201) put in line with the mark and tighten the actuator locknut (256) counter-clockwise. The vent plug shall be at a right angle to the yoke legs.

NOTICE Use a rounded chisel and a hammer.

10. Screw in the lock nut (344) and the actuator coupling (249) - screw-in depth once thread diameter - counter-clockwise and fix it. Aligning the coupling parallel to the yoke.
11. Further reassembling steps are only possible with the valve (see page 39).

Item #		Part
WW	EU	
201	5.9	Yoke
213	5.7	Stroke Scale
216	5.6	Stroke Indicator
240	5.5	Socket Head Screw (2x)
249	5.3	Actuator Coupling
256	5.11	Actuator Locknut
344	5.4	Lock Nut
345	5.1	Valve Coupling ¹⁾
420	5.8	Hex Bolt

¹⁾ Depending on the valve series (see page 7).

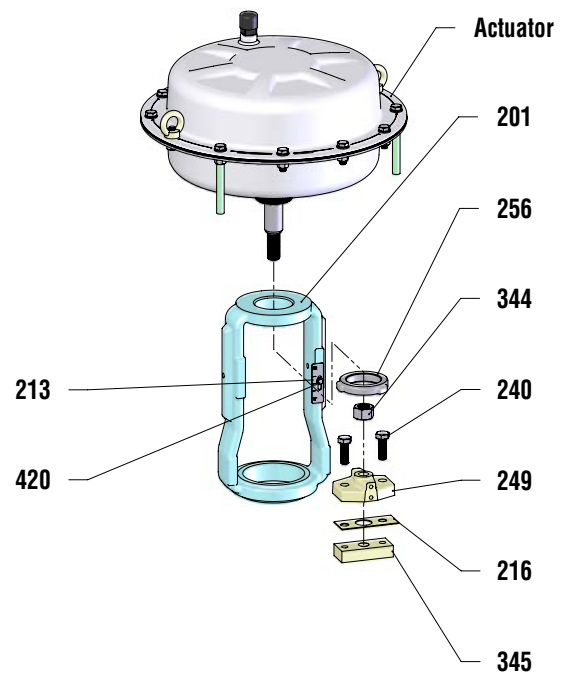

Figure 19: Actuator parts

Actuator with MULTI-yoke

Spring-to-close or -open

Disassembly instruction of the yoke

NOTICE Limit disassembly only to necessary components.

1. Fix the actuator on the assembly table, if this is not already happened (see also pages 14 - 15).
2. Remove the hex bolt (420), washer (333) and the stroke scale (213).
3. Remove the socket head screw (214), washer (334) and the stroke indicator (216).
4. Unlock the lock nut (344) counter-clockwise.
5. Loosen the actuator coupling (249) and lock nut (344) clockwise.
6. We recommend you not to remove the actuator from the yoke. If this is indispensable mark the position, loosen the actuator locknut (256) clockwise and lift off the actuator and O-ring (271).

NOTICE Use a rounded chisel and a hammer.

Item #		Part
WW	EU	
201	5.9	Yoke
213	5.7	Stroke Scale
214	5.20	Socket Head Screw
216	5.6	Stroke Indicator
240	5.5	Socket Head Screw (2x)
249	5.3	Actuator Coupling
256	5.11	Actuator Locknut
271	6.50	O-Ring
278	6.51	O-Ring
333	5.12	Washer (4x)
334	5.19	Washer
344	5.4	Lock Nut
345	5.1	Valve Coupling ¹⁾
420	5.8	Hex Bolt (4x)

¹⁾ Depending on the valve series (see page 7).

Table 23: Actuator parts

7. Store all coupling and yoke-parts safely, lose no parts.
8. For disassemble the attachments see pages 26 - 33 and for actuator subassembly see pages 18 - 25.

Reassembly instruction of the yoke

9. Lubricate the threads of the actuator and stroke coupling-parts with an appropriate lubricant.
10. If necessary mount new O-rings (278, 271) and the actuator onto the yoke (201) put in line with the mark and tighten the actuator locknut (256) counter-clockwise. The vent plug shall be at a right angle to the yoke legs.

NOTICE Use a rounded chisel and a hammer.

11. Screw in the lock nut (344) and the actuator coupling (249) - screw-in depth once thread diameter - counter-clockwise and fix it. Aligning the coupling parallel to the yoke.
12. Further reassembling steps are only possible with the valve (see page 39).

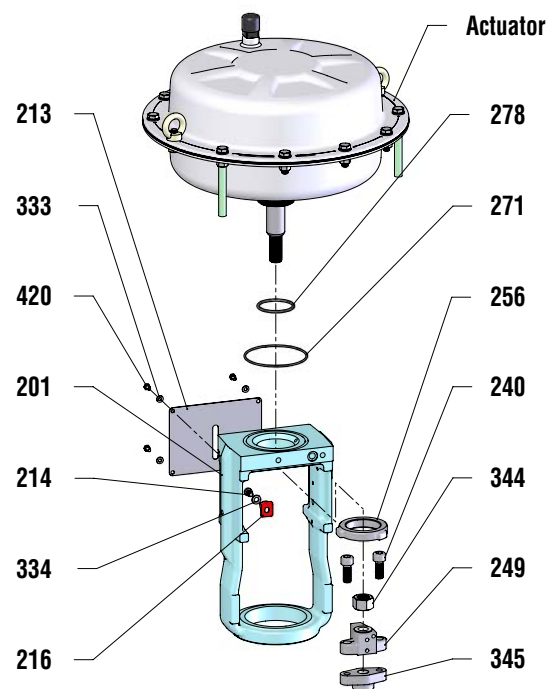

Figure 20: Actuator parts

Actuator with IAS-yoke

Spring-to-close or -open

Disassembly instruction of the yoke

NOTICE Limit disassembly only to necessary components.

1. Fix the actuator on the assembly table, if this is not already happened (see also pages 14 - 15).
2. Remove the socket head screw (214) and the stroke indicator (216).
3. Unlock the lock nut (344) counter-clockwise.
4. Loosen the actuator coupling (249) and lock nut (344) clockwise.
5. We recommend you not to remove the actuator from the yoke. If this is indispensable mark the position, loosen the actuator locknut (256) clockwise and lift off the actuator and O-ring (271).

NOTICE Use a rounded chisel and a hammer.

6. Store all coupling and yoke-parts safely, lose no parts.
7. For disassemble the attachments see pages 26 - 33 and for actuator subassembly see pages 18 - 25.

Item #		Part
WW	EU	
201	5.9	Yoke
213	5.7	Stroke Scale
214	5.20	Socket Head Screw
216	5.6	Stroke Indicator
240	5.5	Socket Head Screw (2x)
249	5.3	Actuator Coupling
256	5.11	Actuator Locknut
271	6.50	O-Ring
278	6.51	O-Ring
344	5.4	Lock Nut
345	5.1	Valve Coupling ¹⁾
420	5.8	Hex Bolt

¹⁾ Depending on the valve series (see page 7).

Reassembly instruction of the yoke

8. Lubricate the threads of the actuator and stroke coupling-parts with an appropriate lubricant.
9. If necessary mount new O-rings (278, 271) and the actuator onto the yoke (201) put in line with the mark and tighten the actuator locknut (256) counter-clockwise. The vent plug shall be at a right angle to the yoke legs.

NOTICE Use a rounded chisel and a hammer.

10. Screw in the lock nut (344) and the actuator coupling (249) - screw-in depth once thread diameter - counter-clockwise and fix it. Aligning the coupling parallel to the yoke.
11. Further reassembling steps are only possible with the valve (see page 39).

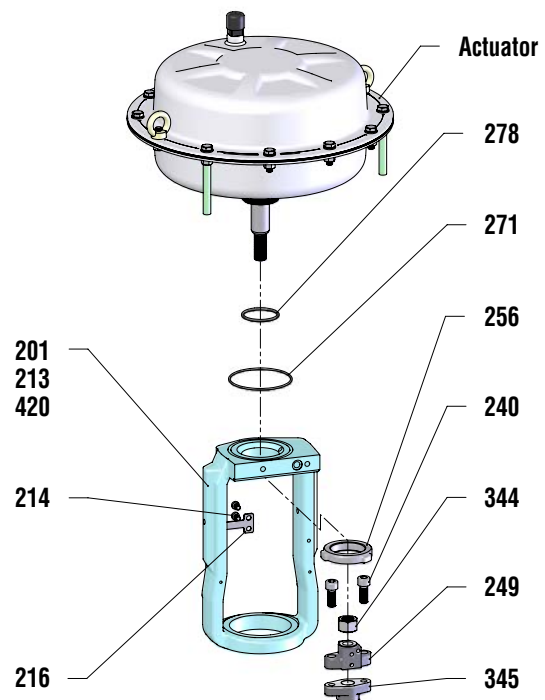

Figure 21: Actuator parts

Actuator with Handwheel - side

> Type 253 < Spring-to-close or -open

Disassembly instruction of the yoke

NOTICE Limit disassembly only to necessary components.

1. Loosen the hex bolts (150) and washers (140), remove the handwheel-side (393) and store all parts safely.
1. Fix the actuator on the assembly table, if this is not already happened (see also pages 14 - 15).
2. Unlock the lock nut (344) counter-clockwise.
3. Loosen the actuator coupling (249) and lock nut (344) clockwise.
4. We recommend you not to remove the actuator from the yoke. If this is indispensable mark the position, loosen the actuator locknut (256) clockwise and lift off the actuator and O-ring (271).

NOTICE Use a rounded chisel and a hammer.

5. Store all coupling and yoke-parts safely, lose no parts.

Item #		Part
WW	EU	
140	6.91	Washer (4x)
150	6.92	Hex Bolt (4x)
201	5.9	Yoke
213	5.7	Stroke Scale
216	5.6	Stroke Indicator
240	5.5	Socket Head Screw (2x)
249	5.3	Actuator Coupling
256	5.11	Actuator Locknut
271	6.50	O-Ring
278	6.51	O-Ring
344	5.4	Lock Nut
345	5.1	Valve Coupling
393	6.90	Lateral Handwheel (Unit)
420	5.8	Hex Bolt

Table 25: Actuator parts

6. For disassemble the attachments see pages 26 - 33 and for actuator subassembly see pages 18 - 25.

Reassembly instruction of the yoke

7. Lubricate the threads of the actuator and stroke coupling-parts with an appropriate lubricant.
8. If necessary mount new O-rings (278, 271) and the actuator onto the yoke (201) put in line with the mark and tighten the actuator locknut (256) counter-clockwise. The vent plug shall be at left rear to the yoke legs.

NOTICE Use a rounded chisel and a hammer.

9. Screw in the lock nut (344) and the actuator coupling (249) - screw-in depth once thread diameter - counter-clockwise and fix it. Aligning the coupling parallel to the yoke.
10. Further reassembling steps are only possible with the valve (see page 39).

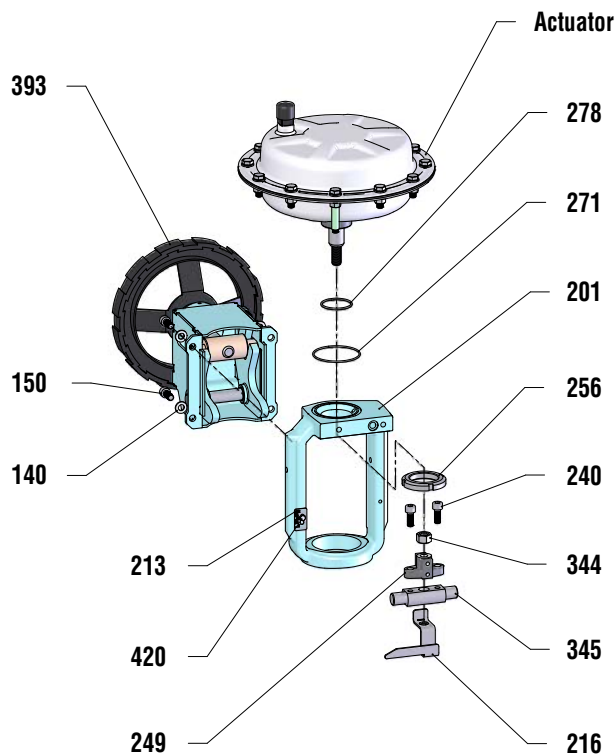

Figure 22: Actuator parts

Actuator with Handwheel - side

> Type 503, 701 < Spring-to-close or -open

Disassembly instruction of the yoke

NOTICE Limit disassembly only to necessary components.

1. Loosen the hex bolts (150) and washers (140), remove the handwheel-side (393).
2. Loosen the socket head screw (214) and stroke indicator (216) and store all parts safely.
3. Disassemble the actuator and fix the yoke on the assembly table (see pages 14 - 15).
4. Unlock the lock nut (344) counter-clockwise.
5. Loosen the actuator coupling (249) and lock nut (344) clockwise.
6. We recommend you not to remove the actuator from the yoke. If this is indispensable mark the position, loosen the actuator locknut (256) clockwise and lift off the actuator and O-ring (271).

NOTICE Use a rounded chisel and a hammer.

Item #		Part
WW	EU	
140	6.91	Washer (4x)
150	6.92	Hex Bolt (4x)
201	5.9	Yoke
213	5.7	Stroke Scale
214	5.20	Socket Head Screw (2x)
216	5.6	Stroke Indicator
240	5.5	Socket Head Screw (2x)
249	5.3	Actuator Coupling
256	5.11	Actuator Locknut
271	6.50	O-Ring
278	6.51	O-Ring
344	5.4	Lock Nut
345	5.1	Valve Coupling
393	6.90	Lateral Handwheel (Unit)
420	5.8	Hex Bolt

Table 26: Actuator parts

7. Store all coupling and yoke-parts safely, lose no parts.
8. For disassemble the attachments see pages 26 - 33 and for actuator subassembly see pages 18 - 25.

Reassembly instruction of the yoke

9. Lubricate the threads of the actuator and stroke coupling-parts with an appropriate lubricant.
10. If necessary mount new O-rings (278, 271) and the actuator onto the yoke (201) put in line with the mark and tighten the actuator locknut (256) counter-clockwise. The vent plug shall be at left rear to the yoke legs.

NOTICE Use a rounded chisel and a hammer.

11. Screw in the lock nut (344) and the actuator coupling (249) - screw-in depth once thread diameter - counter-clockwise and fix it. Aligning the coupling parallel to the yoke.
12. Further reassembling steps are only possible with the valve (see page 39).

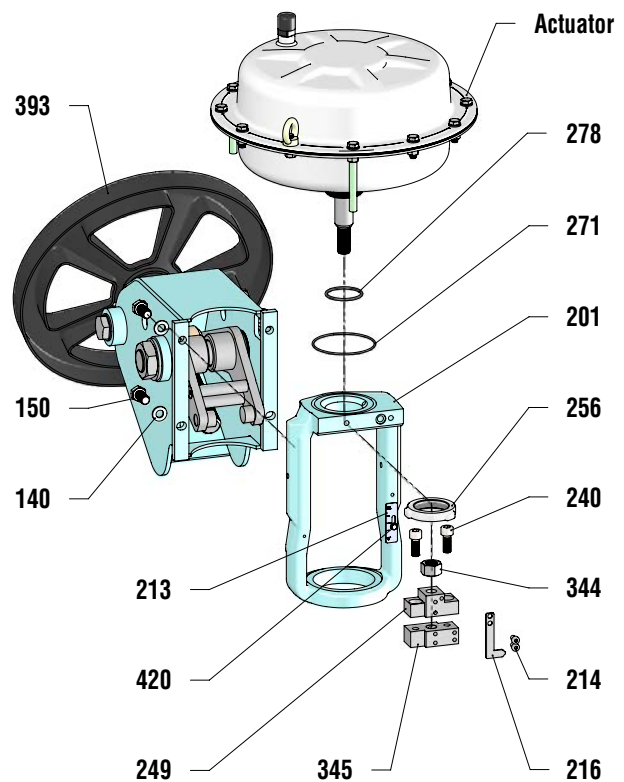



Figure 23: Actuator parts

Pneumatic Actuator - Type 1502

- Type 253, 503, 701 see page 17
- Type 3002 see page 57

Adjustable Limit Stop - max. positioning force 39 kN

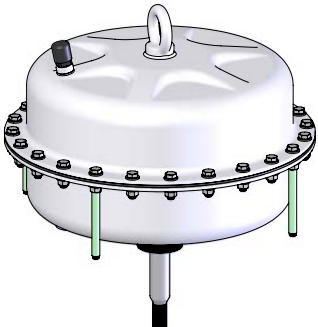
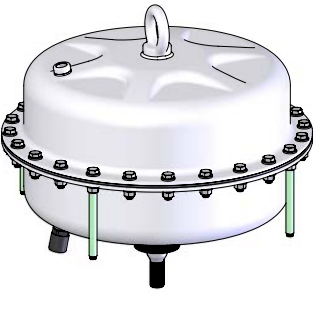
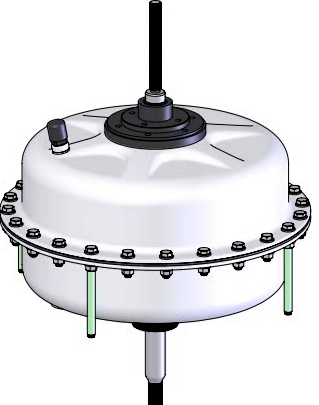
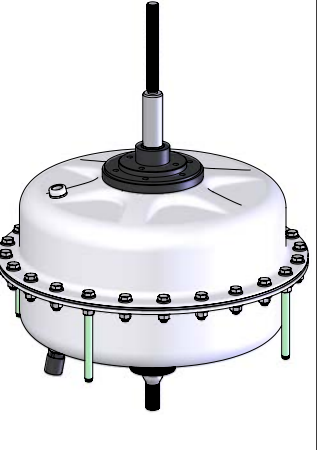

see pages 48 - 49

Single chamber actuator without attachments		Single chamber actuator with attachments	
Spring-to-close	Spring-to-open	Spring-to-close	Spring-to-open
			
see pages 40 - 41	see pages 42 - 43	see pages 44 - 45	see pages 46 - 47

Central-mounted handwheel

without

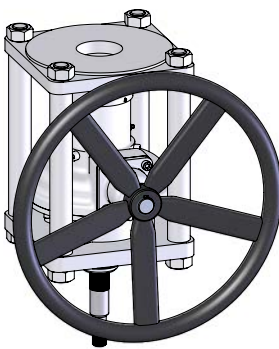

see pages 50 - 53

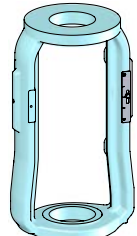
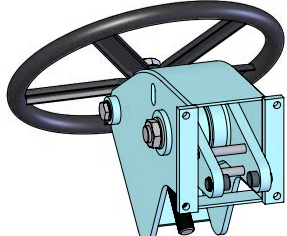
NAMUR-yoke, with double mounting pads	Side-mounted handwheel - maximal positioning force 39 kN
	
see page 54	see page 55

Actuator without attachments

Spring-to-close

Disassembly instruction of the actuator sub-assembly

NOTICE *Limit disassembly only to necessary components.*

1. Fix the actuator on the assembly table (see page 15).
2. Disassemble the coupling parts and yoke (see page 54).
3. Disassemble the hexagon bolts (335), plain washers (337) and hexagon nuts (351).
4. Pull off the protection sleeve (339).

⚠ WARNING **Risk of injury by jumping out parts ! Pre-loaded springs inside.**

5. Lubricate the threads and loosen the long hexagon bolts (336), plain washers (337) and hexagon nuts (351) uniformly in a clockwise sequence as the springs expand.

NOTICE *We recommend using threaded bolts meeting standards from ISO 898-1, 8.8 or higher, as well as washers and nuts.*

6. Lift off the diaphragm casing (203, 258), distance plate (231) and spring adjusting plate (326).
7. Remove the actuator springs (229).
8. Carefully remove the diaphragm-stem unit (211 - 374).
9. Remove the scraper ring (273) and O-ring (275).
10. Secure the diaphragm-stem unit into the Special Tool.
11. Loosen the special nut (348) counterclockwise and remove the lock washer (349), distance bushing (374), spacer bushing (228), disk (220), diaphragm plate (227), diaphragm (225), O-ring (272) and thrust washer (255).
12. Check stressed surface areas for damage such as scoring and deformities. Use a brass brush or similar tool to clean bolting. Check for corrosion or any other damage.

Reassembly instruction of the actuator sub-assembly

NOTICE *Always replace parts showing wear with new parts.*

13. Lubricate the new O-ring (275), new scraper ring (273) with an appropriate lubricant and install into the guide bushing (253).
14. Lubricate the new O-ring (272) with an appropriate lubricant.
15. Lower the thrust washer (255), O-ring (272), diaphragm (225), diaphragm plate (227), disk (220), spacer bushing (228), distance bushing (374) and lock washer (349) onto the stem (211).
16. Lubricate the thread of the stem (211) with an appropriate lubricant and install and finger tighten the special nut (348).

NOTICE *The diaphragm plate should be positioned to the diaphragm with the aid of the Positioning Template. Mark the position.*

17. Turn the special nut (348) clockwise using a suitable torque wrench.
18. Loosen and remove the diaphragm-stem unit (211-349) from the Special Tool. Lubricate the actuator stem with an appropriate lubricant.
19. Carefully lower the diaphragm-stem unit (211- 349) into the diaphragm casing.

NOTICE *Position the diaphragm-stem unit such that the air connection and the Mark align.*

20. Install and align the actuator springs (229).
21. Install and position the spring adjusting plate (326) such that the imprint on the plate and air connection are opposite of each other.
22. Install the distance plate (231) and diaphragm casing (203), position the casing allowing the air connections to be opposite of each other.
23. Lubricate the threads of the long hexagon bolts (336) with an appropriate lubricant then compress the springs uniformly in a clockwise sequence by tightening the long hexagon bolts (336), plain washers (337) and hexagon nuts (351). Alternative method *see NOTICE* step 5.

- 24. Install the short hexagon bolts (335) and hexagon nuts (351).
- 25. Tighten the nuts (351) using a crosswise pattern in four steps.
- 26. Install the protection sleeve (339).
- 27. Reassemble the yoke and coupling parts, perform three full strokes then check the tightening of the casing bolting.
- 28. Log the maintenance interval and the work performed.

29. The actuator subassembly is ready to be mounted on the valve and the accessories attached.

Item #		Part
WW	EU	
202	6.1	Diaphragm Casing
203	6.2	Diaphragm Casing
211	6.12	Stem
220	6.14	Disk
225	6.16	Diaphragm
227	6.15	Diaphragm Plate
228	6.13	Spacer Bushing
229	6.21	Actuator Spring
231	6.22	Distance Plate
253	6.8	Guide Bushing
254	6.80	Plain Bearing
255	6.18	Thrust Washer
258	6.26	Vent Plug
272	6.17	O-Ring
273	6.11	Scraper Ring
275	6.10	O-Ring
276	6.9	O-Ring
279	6.46	O-Ring
326	6.23	Spring Adjusting Plate
334	6.45	Hexagon Bolt (6x)
335	6.3.1	Hexagon Bolt - short (20x)
336	6.3.2	Hexagon Bolt - long (4x)
337	6.5	Plain Washer ¹⁾
339	6.25	Protection Sleeve (4x)
348	6.20	Special Nut
349	6.19	Lock Washer
351	6.4	Hexagon Nut
374	6.47	Distance Bushing

¹⁾ Alternatively, hex head assembled screws with captive flat washers are used for this application.

Table 27: Actuator parts

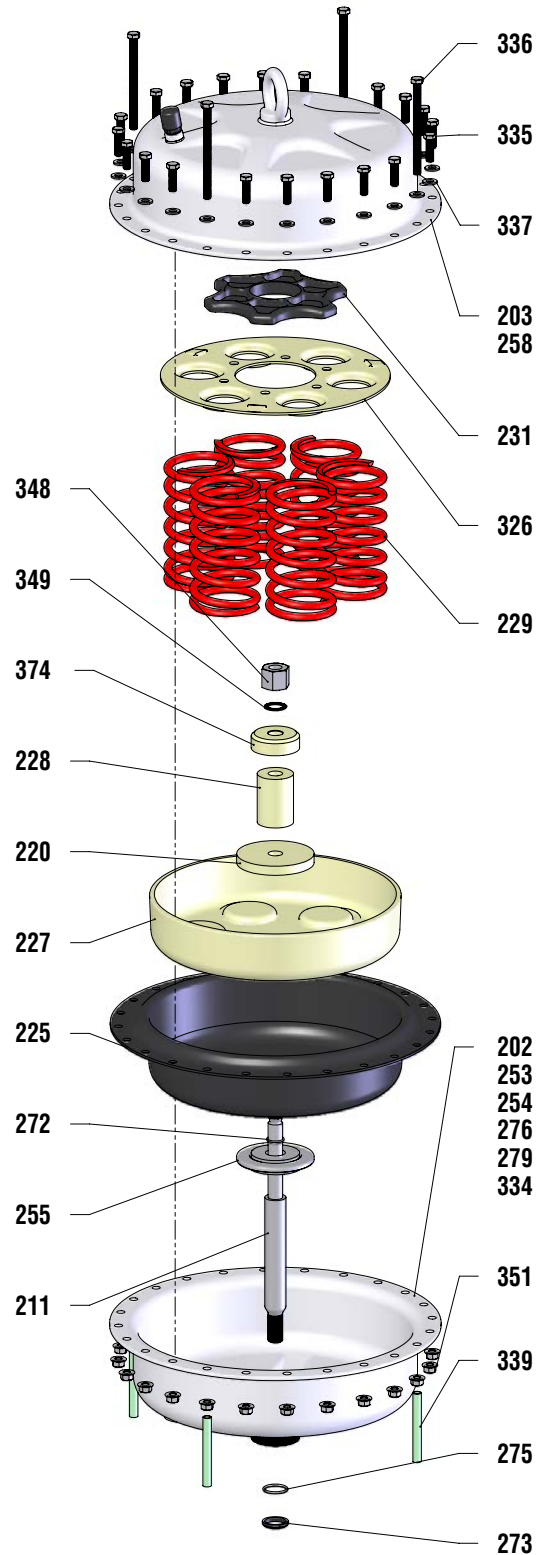

Figure 24: Actuator parts

Actuator without attachments

Spring-to-open

Disassembly instruction of the actuator subassembly

NOTICE *Limit disassembly only to necessary components.*

1. Fix the actuator on the assembly table, if this is not already happened.
2. Disassemble the coupling parts and yoke (see page 54).
3. Disassemble the hexagon bolts (335), plain washers (337) and hexagon nuts (351).
4. Pull off the protection sleeve (339).

⚠ WARNING **Risk of injury by jumping out parts ! Pre-loaded springs inside.**

5. Lubricate the threads and loosen the long hexagon bolts (336), plain washers (337) and hexagon nuts (351) uniformly in a clockwise sequence as the springs expand.

NOTICE *We recommend using threaded bolts meeting standards from ISO 898-1, 8.8 or higher, as well as washers and nuts.*

6. Lift off the diaphragm casing (203, 258).
7. Carefully remove the diaphragm-stem unit (211 - 374).
8. Remove the actuator springs (229).
9. Remove the spring adjusting plate (326) and distance plate (231).
10. Remove the scraper ring (273) and O-ring (275).
11. Secure the diaphragm-stem unit into the Special Tool.
12. Loosen the special nut (348) counterclockwise and remove the lock washer (349), thrust washer (255), O-ring (272), diaphragm (225), diaphragm plate (227), disk (220), spacer bushing (228) and distance bushing (231).
13. Check stressed surface areas for damage such as scoring and deformities. Use a brass brush or similar tool to clean bolting. Check for corrosion or any other damage.

Reassembly instruction of the actuator subassembly

NOTICE *Always replace parts showing wear with new parts.*

14. Lubricate the new O-ring (275), new scraper ring (273) with an appropriate lubricant and install into the guide bushing (253).
15. Lubricate the new O-ring (272) with an appropriate lubricant.
16. Lower the distance bushing (374), spacer bushing (228), disk (220), diaphragm plate (227), diaphragm (225), O-ring (272), thrust washer (255), lock washer (349) onto the stem (211).
17. Lubricate the thread of the stem (211) with an appropriate lubricant and install and finger tighten the special nut (348).
18. Turn the special nut (348) clockwise using a suitable torque wrench.
19. Loosen and remove the diaphragm-stem unit (211-349) from the Special Tool. Lubricate the actuator stem with an appropriate lubricant.
20. Install and position the distance plate (231), spring adjusting plate (326) allowing the air connections to be opposite of each other.
21. Install and align the actuator springs (229).
22. Carefully lower the diaphragm-stem unit (211- 349) into the diaphragm casing.
23. Install the diaphragm casing (203), positioning the casing such that the air connections are aligned.
24. Lubricate the threads of the long hexagon bolts (336) with an appropriate lubricant then compress the springs uniformly in a clockwise sequence by tightening the long hexagon bolts (336), plain washers (337) and hexagon nuts (351). Alternative method *see NOTICE* step 5.
25. Install the short hexagon bolts (335), hexagon nuts (351).

- 26. Tighten the nuts (351) using a crosswise pattern in four steps.
- 27. Install the protection sleeve (339).
- 28. Reassemble the yoke and coupling parts, perform three full strokes then check the tightening of the casing bolting.
- 29. Log the maintenance interval and the work performed.

30. The actuator subassembly is ready to be mounted on the valve and the accessories attached.

Item #		Part
WW	EU	
202	6.1	Diaphragm Casing
203	6.2	Diaphragm Casing
211	6.12	Stem
220	6.14	Disk
225	6.16	Diaphragm
227	6.15	Diaphragm Plate
228	6.13	Spacer Bushing
229	6.21	Actuator Spring
231	6.22	Distance Plate
253	6.8	Guide Bushing
254	6.80	Plain Bearing
255	6.18	Thrust Washer
258	6.26	Vent Plug
272	6.17	O-Ring
273	6.11	Scraper Ring
275	6.10	O-Ring
276	6.9	O-Ring
279	6.46	O-Ring (6x)
326	6.23	Spring Adjusting Plate
334	6.45	Hexagon Bolt
335	6.3.1	Hexagon Bolt - short (20x)
336	6.3.2	Hexagon Bolt - long (4x)
337	6.5	Plain Washer (24x) ¹⁾
339	6.25	Protection Sleeve
348	6.20	Special Nut
349	6.19	Lock Washer
351	6.4	Hexagon Nut
374	6.47	Distance Bushing

¹⁾ Alternatively, hex head assembled screws with captive flat washers are used for this application.

Table 28: Actuator parts

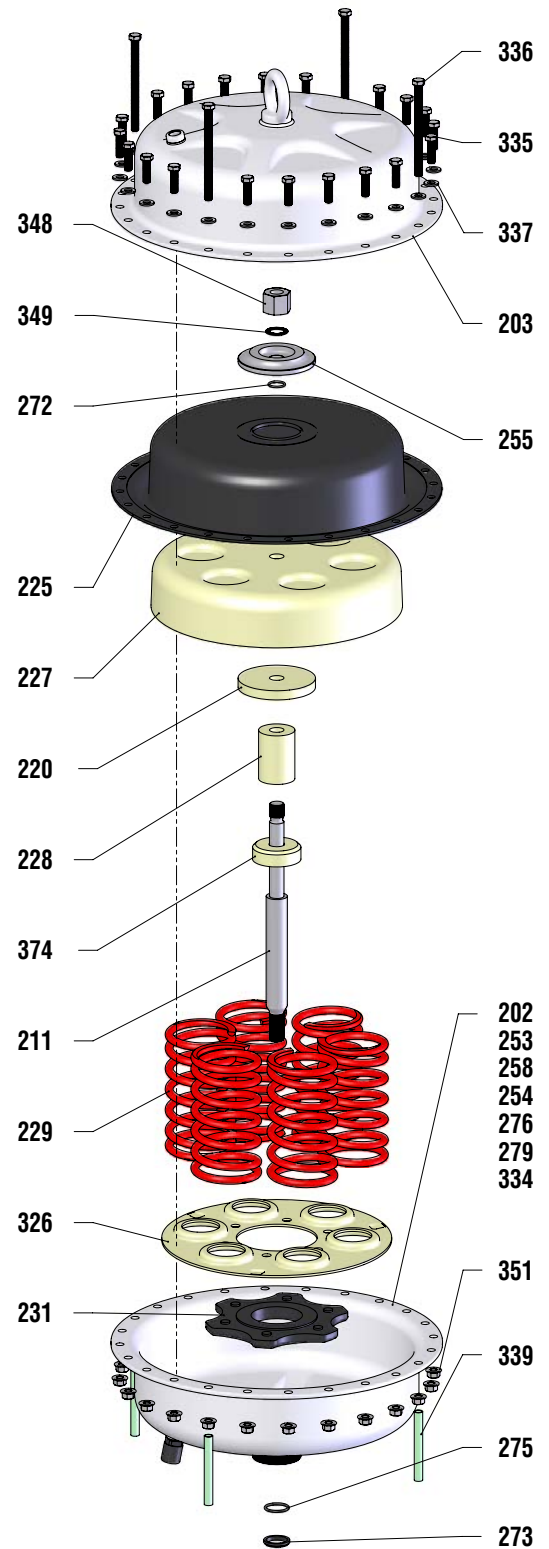

Figure 25: Actuator parts

Actuator with attachments

Spring-to-close

Disassembly instruction of the actuator subassembly

NOTICE *Limit disassembly only to necessary components.*

1. Fix the actuator on the assembly table, if this is not already happened.
2. Disassemble the coupling parts and yoke (see page 54).
3. Disassemble the hexagon bolts (335), plain washers (337) and hexagon nuts (351).
4. Pull off the protection sleeve (339).

⚠ WARNING **Risk of injury by jumping out parts ! Pre-loaded springs inside.**

5. Lubricate the threads and loosen the long hexagon bolts (336), plain washers (337) and hexagon nuts (351) uniformly in a clockwise sequence as the springs expand.

NOTICE *We recommend using threaded bolts meeting standards from ISO 898-1, 8.8 or higher, as well as washers and nuts.*

6. Lift off the diaphragm casing (202 - 389), distance plate (231) and spring adjusting plate (326).
7. Remove the actuator springs (229).
8. Carefully pull out the diaphragm-stem unit (211 - 374).
9. Remove the scraper rings (273) and O-rings (275).
10. Secure the diaphragm-stem unit into the Special Tool.
11. Loosen the stem (348) counterclockwise and remove the lock washer (349), distance bushing (374), spacer bushing (228), disk (220), diaphragm plate (227), diaphragm (225), O-ring (272) and thrust washer (255).
12. Check stressed surface areas for damage such as scoring and deformities. Use a brass brush or similar tool to clean bolting. Check for corrosion or any other damage.

Reassembly instruction of the actuator subassembly

NOTICE *Always replace parts showing wear with new parts.*

13. Lubricate the new O-rings (275), new scraper rings (273) with an appropriate lubricant and install into the guide bushings (253).
14. Lubricate the new O-ring (272) with an appropriate lubricant.
15. Lower the thrust washer (255), O-ring (272), diaphragm (225), diaphragm plate (227), disk (220), spacer bushing (228), distance bushing (374) and lock washer (349) onto the stem (211).

16. Lubricate the thread of the stem (211) with an appropriate lubricant and install and finger tighten the stem (348).

NOTICE *The diaphragm plate should be positioned to the diaphragm with the aid of the Positioning Template. Mark the position.*

17. Turn clockwise the stem (348) using a suitable torque wrench.
18. Loosen and remove the diaphragm-stem unit (211-374) from the Special Tool. Lubricate the actuator stem with an appropriate lubricant.
19. Carefully lower the diaphragm-stem unit (211- 374) into the diaphragm casing.

NOTICE *Position the diaphragm-stem unit such that the air connection and the Mark align.*

20. Install and align the actuator springs (229).
21. Install and position the spring adjusting plate (326) such that the imprint on the plate and air connection are opposite of each other.
22. Install the distance plate (231) and diaphragm casing (203), position the casing allowing the air connections to be opposite of each other.
23. Lubricate the threads of the long hexagon bolts (336)

with an appropriate lubricant then compress the springs uniformly in a clockwise sequence by tightening the long hexagon bolts (336), plain washers (337) and hexagon nuts (351). Alternative method see *NOTICE* step 5.

- 24. Install the short hexagon bolts (335) and hexagon nuts (351).
- 25. Tighten the nuts (351) using a crosswise pattern in four steps.
- 26. Install the protection sleeve (339).

- 27. Reassemble the yoke and coupling parts, perform three full strokes then check the tightening of the casing bolting.
- 28. Log the maintenance interval and the work performed.
- 29. The actuator subassembly is ready to be mounted on the valve and the accessories attached.

Item #		Part
WW	EU	
202	6.1	Diaphragm Casing (2x)
209	6.6	Ring Nut
211	6.12	Stem
220	6.14	Disk
225	6.16	Diaphragm
227	6.15	Diaphragm Plate
228	6.13	Spacer Bushing
229	6.21	Actuator Spring
231	6.22	Distance Plate
253	6.8	Guide Bushing
254	6.80	Plain Bearing (2x)
255	6.18	Thrust Washer
258	6.26	Vent Plug
272	6.17	O-Ring
273	6.11	Scraper Ring (2x)
275	6.10	O-Ring (2x)
276	6.9	O-Ring (2x)
279	6.46	O-Ring (12x)
326	6.23	Spring Adjusting Plate
334	6.45	Hexagon Bolt (12x)
335	6.3.1	Hexagon Bolt - short (20x)
336	6.3.2	Hexagon Bolt - long (4x)
337	6.5	Plain Washer (24x) ¹⁾
339	6.25	Protection Sleeve
348	6.20	Stem
349	6.19	Lock Washer
351	6.4	Hexagon Nut (24x)
374	6.47	Distance Bushing
389	6.83	Guide Bushing

¹⁾ Alternatively, hex head assembled screws with captive flat washers are used for this application.

Table 29: Actuator parts

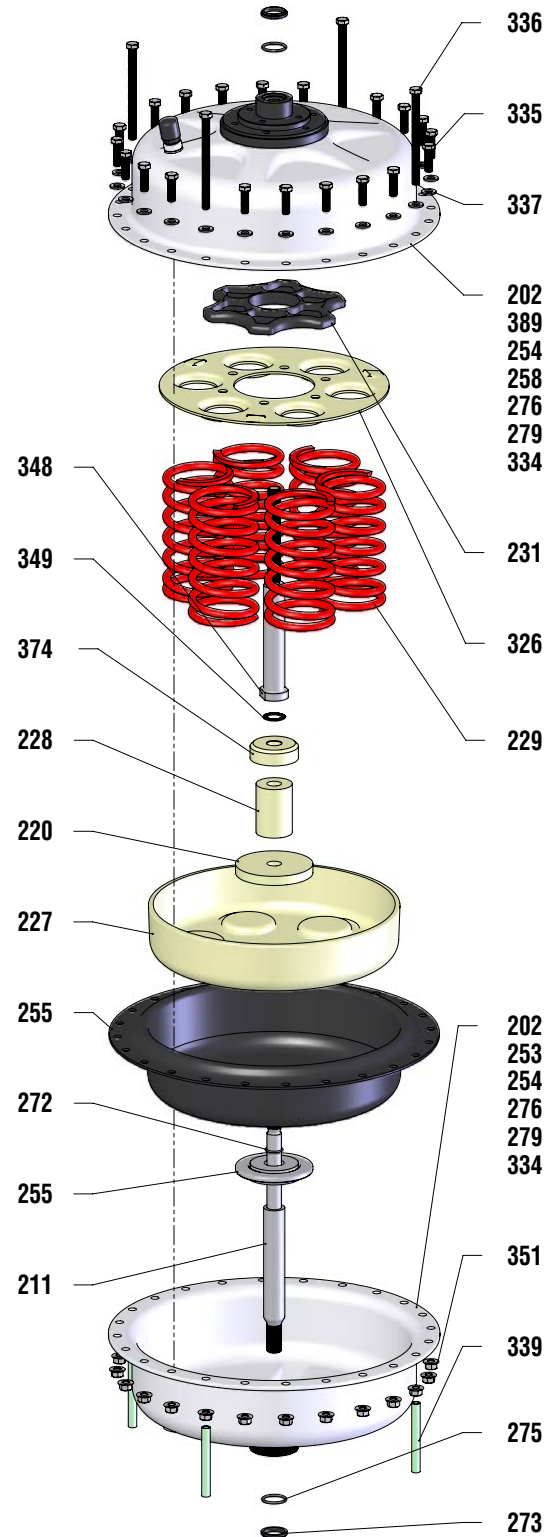

Figure 26: Actuator parts

Actuator without attachments

Spring-to-open

Disassembly instruction of the actuator subassembly

NOTICE *Limit disassembly only to necessary components.*

1. Fix the actuator on the assembly table, if this is not already happened.
2. Disassemble the coupling parts and yoke (see page 54).
3. Disassemble the hexagon bolts (335), plain washers (337) and hexagon nuts (351).
4. Pull off the protection sleeve (339).

⚠ WARNING **Risk of injury by jumping out parts ! Pre-loaded springs inside.**

5. Lubricate the threads and loosen the long hexagon bolts (336), plain washers (337) and hexagon nuts (351) uniformly in a clockwise sequence as the springs expand.

NOTICE *We recommend using threaded bolts meeting standards from ISO 898-1, 8.8 or higher, as well as washers and nuts.*

6. Lift off the diaphragm casing (202 - 389).
7. Carefully pull out the diaphragm-stem unit (211 - 374).
8. Remove the actuator springs (229).
9. Remove the spring adjusting plate (326) and distance plate (231).
10. Remove the scraper rings (273) and O-rings (275).
11. Secure the diaphragm-stem unit into the Special Tool.
12. Loosen the stem (348) counterclockwise and remove the lock washer (349), thrust washer (255), O-ring (272), diaphragm (225), diaphragm plate (227), disk (220), spacer bushing (228) and distance bushing (231).
13. Check stressed surface areas for damage such as scoring and deformities. Use a brass brush or similar tool to clean bolting. Check for corrosion or any other damage.

Reassembly instruction of the actuator subassembly

NOTICE *Always replace parts showing wear with new parts.*

14. Lubricate the new O-rings (275), new scraper rings (273) with an appropriate lubricant and install into the guide bushings (253).
15. Lubricate the new O-ring (272) with an appropriate lubricant.
16. Lower the distance bushing (374), spacer bushing (228), disk (220), diaphragm plate (227), diaphragm (225), O-ring (272), thrust washer (255) and lock washer (349) onto the stem (211).
17. Lubricate the thread of the stem (211) with an appropriate lubricant and install and finger tighten the stem (348).
18. Turn clockwise the stem (348) using a suitable torque wrench.
19. Loosen and remove the diaphragm-stem unit (211-374) from the Special Tool. Lubricate the actuator stem with an appropriate lubricant.
20. Install and position the distance plate (231), spring adjusting plate (326) allowing the air connections to be opposite of each other.
21. Install and align the actuator springs (229).
22. Carefully lower the diaphragm-stem unit (211- 374) into the diaphragm casing.
23. Install the diaphragm casing (203), positioning the casing such that the air connections are aligned.
24. Lubricate the threads of the long hexagon bolts (336) with an appropriate lubricant then compress the springs uniformly in a clockwise sequence by tightening the long hexagon bolts (336), plain washers (337) and hexagon nuts (351). Alternative method *see NOTICE* step 5.
25. Install the short hexagon bolts (335), hexagon nuts (351).
26. Tighten the nuts (351) using a crosswise pattern in four steps.

27. Install the protection sleeve (339).
28. Reassemble the yoke and coupling parts, perform three full strokes then check the tightening of the casing bolting.
29. Log the maintenance interval and the work performed.
30. The actuator subassembly is ready to be mounted on the valve and the accessories attached.

Item #		Part
WW	EU	
202	6.1	Diaphragm Casing (2x)
211	6.12	Stem
220	6.14	Disk
225	6.16	Diaphragm
227	6.15	Diaphragm Plate
228	6.13	Spacer Bushing
229	6.21	Actuator Spring
231	6.22	Distance Plate
253	6.8	Guide Bushing
254	6.80	Plain Bearing
255	6.18	Thrust Washer
258	6.26	Vent Plug
272	6.17	O-Ring
273	6.11	Scraper Ring (2x)
275	6.10	O-Ring (2x)
276	6.9	O-Ring (2x)
279	6.46	O-Ring (12x)
326	6.23	Spring Adjusting Plate
334	6.45	Hexagon Bolt (12x)
335	6.3.1	Hexagon Bolt - short (20x)
336	6.3.2	Hexagon Bolt - long (4x)
337	6.5	Plain Washer (24x) ¹⁾
339	6.25	Protection Sleeve (4x)
348	6.20	Stem
349	6.19	Lock Washer
351	6.4	Hexagon Nut (24x)
374	6.47	Distance Bushing
389	6.83	Guide Bushing

¹⁾ Alternatively, hex head assembled screws with captive flat washers are used for this application.

Table 30: Actuator parts

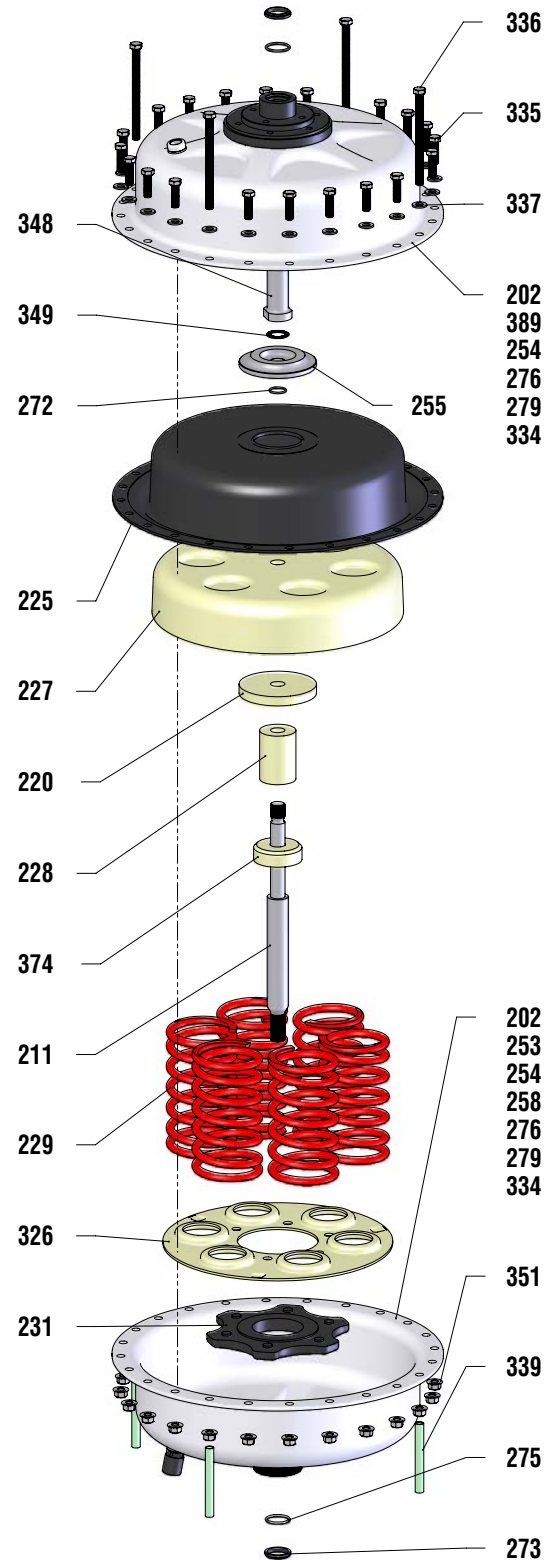

Figure 27: Actuator parts

Actuator with Stroke Limitation

Spring-to-close or -open

Disassembly instruction of the stroke limitation subassembly

NOTICE *Limit disassembly only to necessary components.*

1. Fix the actuator on the assembly table, if this is not already happened.
2. Loosen the hex nut (379) counter-clockwise.
3. Remove the plain washer (376), cover (381) and the pipe section (387).
4. Unlock the lock nuts (350, 2x) counter-clockwise.
5. Loosen the socket head screws (333) counter-clockwise.
6. Lift off the socket head screws (333), plain washers (334), yoke plate (378) and yoke rods (377).
7. Loosen the stud bolt (385) counter-clockwise.
8. Unlock the lock nuts (350, 2x) counter-clockwise.
9. Store all stroke limitation-parts safely, lose no parts.
10. For disassemble the actuator subassembly see pages 46 - 49.
15. Lower the yoke plate (378) onto the stud bolt (385) on the yoke rods (377).
16. Install the plain washers (334) and socket head screws (333) and finger tighten it clockwise.
17. Tighten the socket head screws (333) using a cross-wise pattern clockwise.
18. Mount the lock nuts (350, 2x) clockwise.
19. Connect the actuator with the air supply. Control the air supply until the desired upper and lower stroke position is approached. Position the lock nuts (350) at the end positions and secure them.
20. Place the pipe section (387) onto the upper guide bushing.
21. Place the flange (381) onto the pipe section (387).
22. Mount the washer (376) and hex nuts (379) and finger-tighten.
23. Perform 3 full strokes and check on the stroke indicator whether the desired positions are achieved.
24. Log the maintenance interval and the work performed.
25. The actuator subassembly is ready to be mounted on the valve and the accessories attached.

Reassembly instruction of the stroke limitation subassembly

11. Lubricate the threads of the actuator and stroke limitation-parts with an appropriate lubricant.
12. Mount the lock nuts (350, 2x) clockwise.
13. Mount the stud bolt (385) onto the actuator.
14. Arrange the yoke rods (377, 3x) onto the upper guide bushing.

Item #		Part
WW	EU	
333	6.108	Socket Head Screw (3x)
334	6.107	Plain Washer (3x)
350	6.109	Lock Nut (4x)
376	6.112	Plain Washer
377	6.103	Yoke Rod (3x)
378	6.106	Yoke Plate
379	6.113	Hex Nut
380	6.101	Stem
381	6.111	Cover
385	6.105	Stud Bolt
387	6.110	Pipe Section

Table 31: Stroke limitation parts

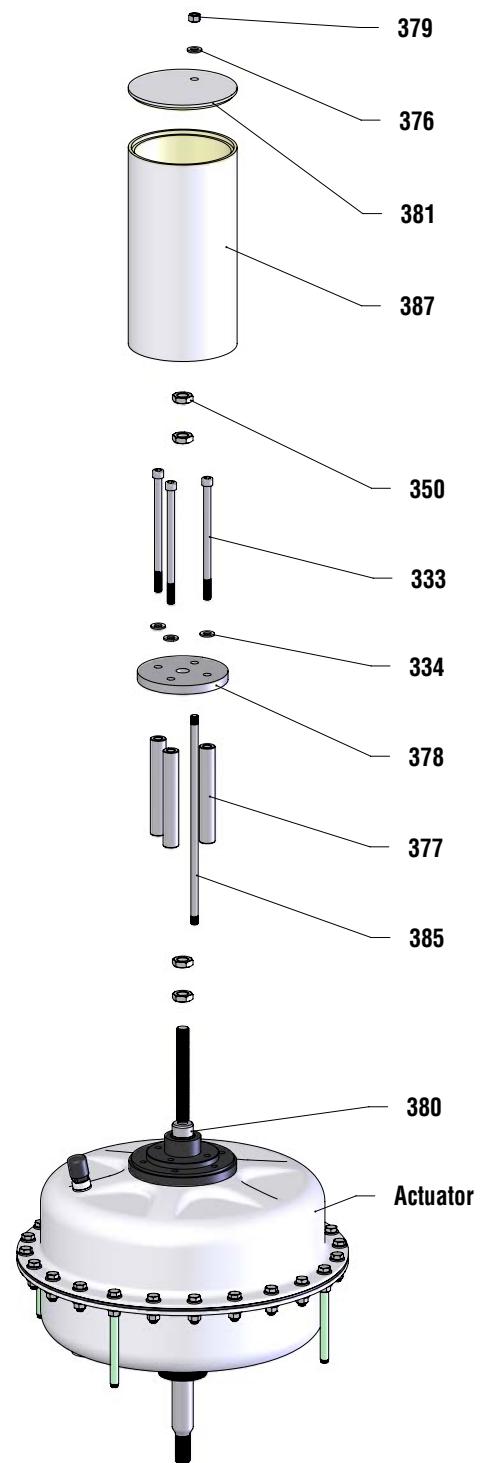

Figure 28: Stroke limitation parts

Actuator with Handwheel - central

Spring-to-close

Disassembly instruction of the handwheel subassembly

NOTICE Limit disassembly only to necessary components.

1. Fix the actuator on the assembly table, if this is not already happened.
2. Disassemble the coupling parts (see page 54).
3. Loosen the hex socket set screw (370) counter-clockwise.

NOTICE The handwheel must be in the neutral position.

4. Remove the handwheel (372).
5. Loosen the slotted set screws (405, 3x) counter-clockwise and push the cover tube (352) down.
6. Loosen the lock nut (256) clockwise and lift off the actuator.

NOTICE Use a rounded chisel and a hammer.

7. Unlock the hex nut (253) counter-clockwise.
8. Unscrew the stem extension unit (221, 350, 405) clockwise.
9. We recommend you not to remove the stem end stop from the stem extension. If this is indispensable loosen the slotted set screw (405) counter-clockwise and unscrew the stem end stop (350) counter-clockwise.
10. Store all handwheel-parts safely, lose no parts.
11. For disassemble the actuator subassembly see pages 42 - 49.

Reassembly instruction of the handwheel subassembly

NOTICE Always replace parts showing wear with new parts.

12. Lubricate the threads of the actuator and handwheel-parts with an appropriate lubricant.
13. If the stem end stop (350) has been removed, reinstall it first. Mount it clockwise onto the stem extension (221) and secure it with the slotted set screw (405).
14. Mount the lock nut (353) counter-clockwise onto the actuator stem.
15. Mount the stem extension unit (221, 350, 405) counter-clockwise onto the actuator stem in such a way that the correct thread screwing depths are given, lock the lock nut (353) clockwise.
16. Arrange the lock nut (256) onto the cover tube (352).
17. Carefully place the actuator assembly onto the handwheel.

NOTICE The handwheel must be in the neutral position.

18. Mount and tighten the lock nut (256) counter-clockwise.

NOTICE Use a rounded chisel and a hammer.

19. Push the cover tube(352) upwards until it stops and lock the slotted set screws (405, 3x) clockwise.
20. Place the handwheel (372) onto the transmission shaft of the bevel gear and secure it with the hex socket set screw (370) clockwise.
21. Assemble the coupling parts (see page 54).

22. Connect the actuator with the air supply, perform 3 full strokes and check the free movement.

NOTICE *The stem extension must be able to move freely without hitting in the end positions.*

23. Log the maintenance interval and the work performed.

24. The actuator subassembly is ready to be mounted on the valve and the accessories attached.

Item #		Part
WW	EU	
221	6.120	Stem Extension
256	5.11	Lock Nut
350	6.122	Stem End Stop
352	6.121	Cover Tube
353	6.124	Lock Nut
370	6.96	Hex Socket Set Screw
372	6.42	Central Handwheel (Unit)
405	6.123	Slotted Set Screw (4x)

Table 32: Handwheel "central" parts

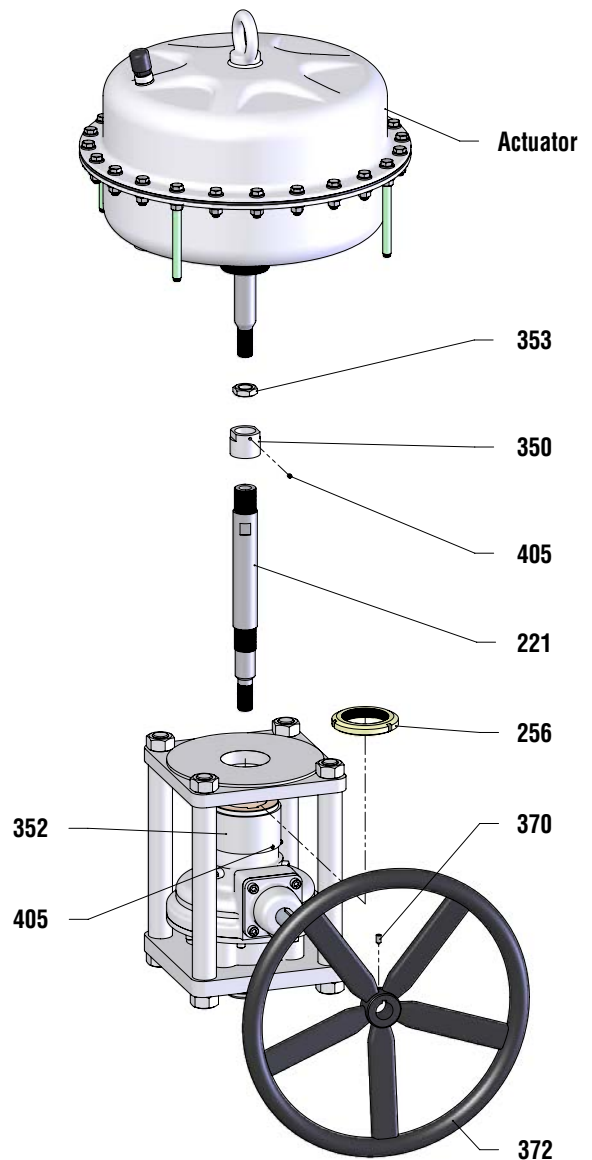

Figure 29: Handwheel "central" parts

Actuator with Handwheel - central

Spring-to-open

Disassembly instruction of the handwheel subassembly

NOTICE *Limit disassembly only to necessary components.*

1. Fix the actuator on the assembly table, if this is not already happened.
2. Disassemble the coupling parts (see page 54).
3. Loosen the hex socket set screw (370) counter-clockwise.

NOTICE *The handwheel must be in the neutral position.*

4. Remove the handwheel (372).

⚠ WARNING **Crushing hazard ! The actuator stem is under spring load. Never disconnect the air supply during next steps, the stem will retract very quickly.**

5. Connect the air supply to the actuator and move the actuator stem into extended position.
6. Loosen the slotted set screw (405) and unscrew the stem end stop (350) counter-clockwise.
7. Disconnect the air supply, the actuator stem will move into retracted position.
8. Loosen the slotted set screws (405, 3x) counter-clockwise and push the cover tube (352) down.
9. Loosen the lock nut (256) clockwise and lift off the actuator.

NOTICE *Use a rounded chisel and a hammer.*

10. Unlock the hex nut (353) counter-clockwise.
11. Unscrew the stem extension unit (221) clockwise.
12. Store all handwheel-parts safely, lose no parts.
13. For disassemble the actuator subassembly see pages 42 - 49.

Reassembly instruction of the handwheel subassembly

NOTICE *Always replace parts showing wear with new parts.*

14. Lubricate the threads of the actuator and handwheel-parts with an appropriate lubricant.
15. Mount the lock nut (353) counter-clockwise onto the actuator stem.
16. Mount the stem extension (221) counter-clockwise onto the actuator stem in such a way that the correct thread screwing depths are given, lock the lock nut (353) clockwise.
17. Arrange the lock nut (256) onto the cover tube (352).
18. Carefully place the actuator assembly onto the handwheel.

NOTICE *The handwheel must be in the neutral position.*

19. Mount and tighten the lock nut (256) counter-clockwise.

NOTICE *Use a rounded chisel and a hammer.*

20. Push the cover tube(352) upwards until it stops and lock the slotted set screws (405, 3x) clockwise.

⚠ WARNING **Crushing hazard ! The actuator stem is under spring load. Never disconnect the air supply during next steps, the stem will retract very quickly.**

21. Connect the air supply to the actuator and move the actuator stem into extended position.
22. Mount the stem end stop (350) and lock the slotted set screw (405) clockwise.
23. Disconnect the air supply, the actuator stem will move into retracted position.
24. Place the handwheel (372) onto the transmission shaft of the bevel gear and secure it with the hex socket set

screw (370) clockwise.

25. Assemble the coupling parts (see page 54).
 26. Connect the actuator with the air supply, perform 3 full strokes and check the free movement.
- NOTICE** *The stem extension must be able to move freely without hitting in the end positions.*
27. Log the maintenance interval and the work performed.
 28. The actuator subassembly is ready to be mounted on the valve and the accessories attached.

Item #		Part
WW	EU	
221	6.120	Stem Extension
256	5.11	Lock Nut
350	6.122	Stem End Stop
352	6.121	Cover Tube
353	6.124	Lock Nut
370	6.96	Hex Socket Set Screw
372	6.42	Central Handwheel (Unit)
405	6.123	Slotted Set Screw (4x)

Table 33: Handwheel "central" parts

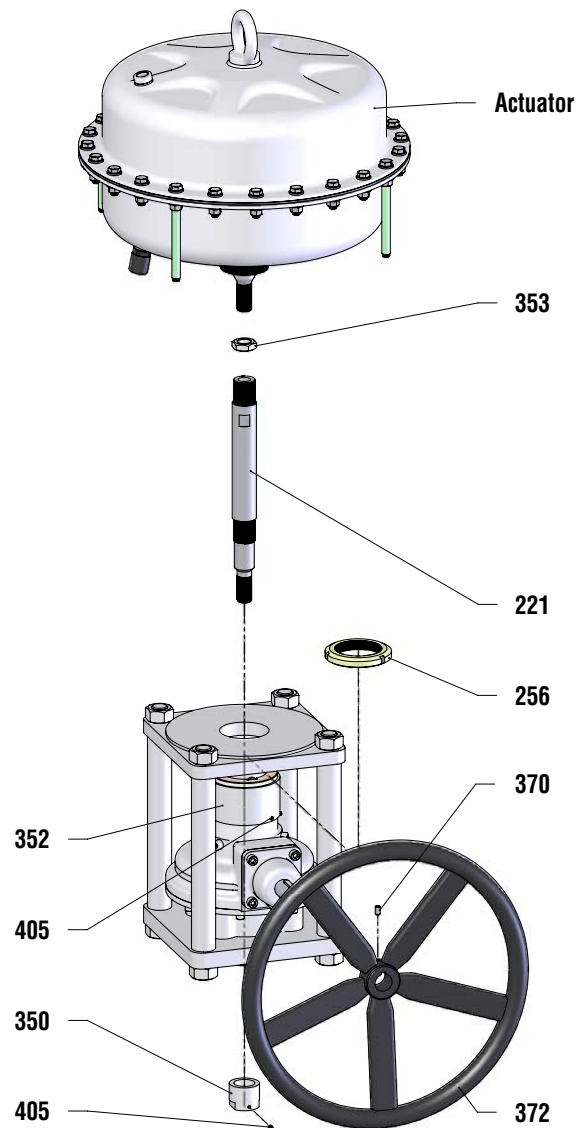

Figure 30: Handwheel "central" parts

Actuator with yoke

Spring-to-close or -open

Disassembly instruction of the yoke

NOTICE Limit disassembly only to necessary components.

1. Fix the actuator on the assembly table, if this is not already happened, see also page 14 - 15.
2. Remove the socket head screws (214), plain washers (334) and the stroke indicator (216).
3. Unlock the lock nut (344) counter-clockwise.
4. Loosen the actuator coupling (249) and lock nut (344) clockwise.
5. We recommend you not to remove the actuator from the yoke. If this is indispensable mark the position, loosen the actuator locknut (256) clockwise and lift off the actuator.

NOTICE Use a rounded chisel and a hammer.

6. Store all coupling and yoke-parts safely, lose no parts.
7. For disassemble the attachments see pages 50 - 51 and for actuator subassembly see pages 42 - 49.

Item #		Part
WW	EU	
76	5.30	Adapter
107	5.32	Hex Bolt
118	5.31	Locking Plate
201	5.9	Yoke
213	5.7	Stroke Scale
214	5.20	Socket Head Screw (2x)
216	5.6	Stroke Indicator
240	5.5	Socket Head Screw (4x)
249	5.3	Actuator Coupling
256	5.11	Actuator Locknut
333	5.12	Plain Washer
334	5.19	Plain Washer (2x)
344	5.4	Lock Nut
345	5.1	Valve Coupling
420	5.8	Hex Bolt

Table 34: Coupling parts

Reassembly instruction of the yoke

8. Lubricate the threads of the actuator and stroke coupling-parts with an appropriate lubricant.
9. If necessary mount actuator onto the yoke (201) put in line with the mark and tighten the actuator locknut (256) counter-clockwise. The vent plug shall be at a right angle to the yoke legs (see figure 31).

NOTICE Use a rounded chisel and a hammer.

10. Screw in the lock nut (344) and the actuator coupling (249) - screw-in depth once thread diameter - counter-clockwise and fix it. Aligning the coupling parallel to the yoke.
11. Mount the stroke indicator (216), plain washers (334) and the socket head screws (214) clockwise.
12. Further reassembling steps are only possible with the valve (see page 39).

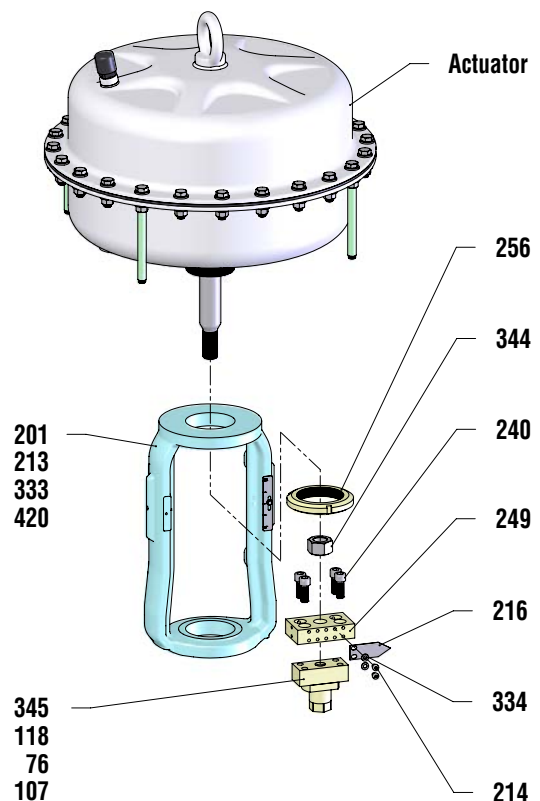

Figure 31: Coupling parts

Actuator with Handwheel - side

Spring-to-close or -open

Disassembly instruction of the yoke

NOTICE Limit disassembly only to necessary components.

1. Fix the actuator on the assembly table, if this is not already happened, see also page 14 - 15.
2. Loosen the hex bolts (150) and remove the handwheel-side (393).
3. Remove the socket head screws (214), plain washers (334) and the stroke indicator (216).
4. Unlock the lock nut (344) counter-clockwise.
5. Loosen the actuator coupling (249) and lock nut (344) clockwise.
6. We recommend you not to remove the actuator from the yoke. If this is indispensable mark the position, loosen the actuator locknut (256) clockwise and lift off the actuator.

NOTICE Use a rounded chisel and a hammer.

7. Store all coupling and yoke-parts safely, lose no parts.
8. For disassemble the attachments see pages 50 - 51

Item #		Part
WW	EU	
76	5.30	Adapter
107	5.32	Hex Bolt
118	5.31	Locking Plate
150	6.92	Hex Bolt (4x)
201	5.9	Yoke
213	5.7	Stroke Scale
214	5.20	Socket Head Screw (2x)
216	5.6	Stroke Indicator
240	5.5	Socket Head Screw (4x)
249	5.3	Actuator Coupling
256	5.11	Actuator Locknut
333	5.12	Plain Washer
334	5.19	Plain Washer (2x)
344	5.4	Lock Nut
345	5.1	Valve Coupling
393	6.95	Lateral Handwheel (Unit)
420	5.8	Hex Bolt

Table 35: Coupling parts

and for actuator subassembly see pages 42 - 49.

Reassembly instruction of the yoke

9. Lubricate the threads of the actuator and stroke coupling-parts with an appropriate lubricant.
10. If necessary mount actuator onto the yoke (201) put in line with the mark and tighten the actuator locknut (256) counter-clockwise. The vent plug shall be at a right angle to the yoke legs (see figure 32).

NOTICE Use a rounded chisel and a hammer.

11. Screw in the lock nut (344) and the actuator coupling (249) - screw-in depth once thread diameter - counter-clockwise and fix it. Aligning the coupling parallel to the yoke.
12. Mount the stroke indicator (216), plain washers (334) and the socket head screws (214) clockwise.
13. Place the handwheel-side (393) mount the hex bolts (150) clockwise.

NOTICE The handwheel must be in the neutral position.

14. Further reassembling steps are only possible with the valve (see page 39).

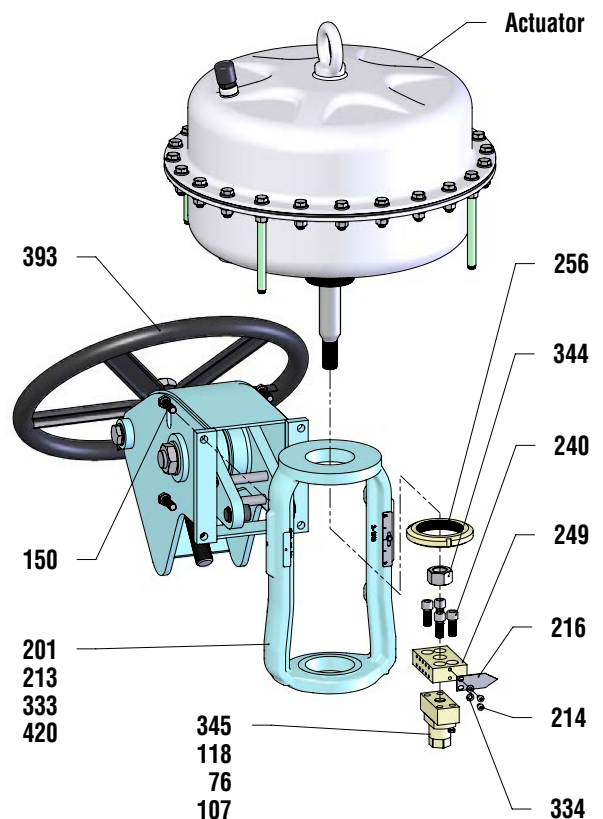

Figure 32: Coupling parts

Space for personal notes

A large grid area for personal notes, consisting of a 20x30 grid of small squares. The grid is empty and occupies the majority of the page below the header.

Pneumatic Actuator - Type 3002

- Type 253, 503, 701 see page 17
- Type 1502 see page 39

Adjustable Limit Stop - max. positioning force 39 kN

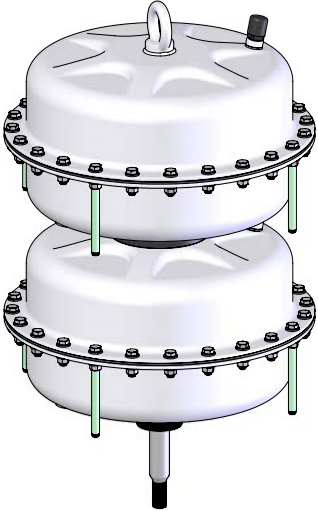
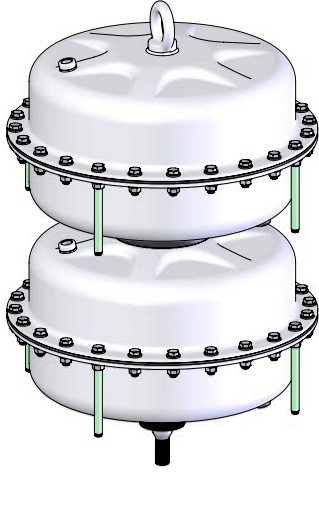
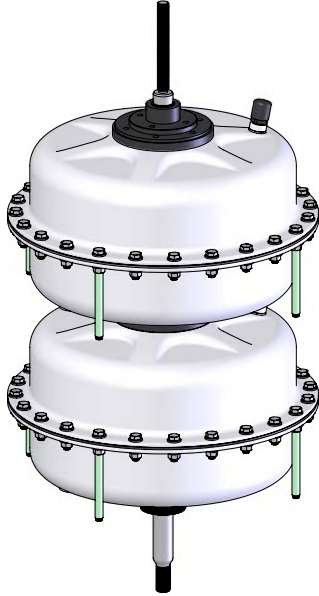
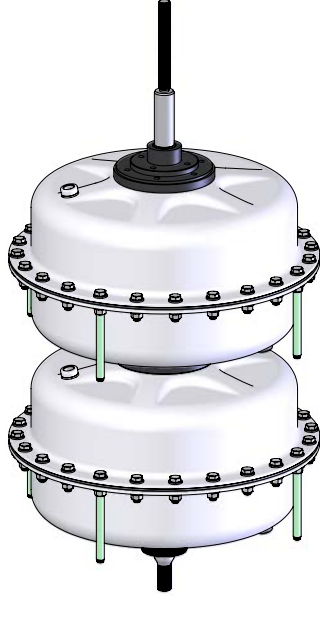

see pages 48 - 49

Single chamber actuator without attachments		Single chamber actuator with attachments	
Spring-to-close	Spring-to-open	Spring-to-close	Spring-to-open
			
see pages 58 - 61	see pages 62 - 65	see pages 66 - 69	see pages 70 - 73

Central-mounted handwheel

without

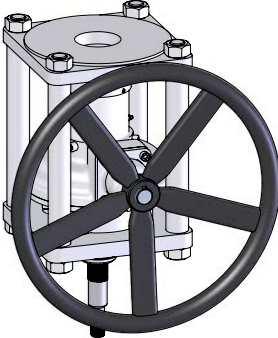

see pages 50 - 53

NAMUR-yoke, with double mounting pads

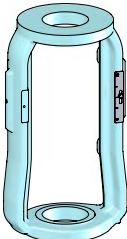

see page 54

Actuator without attachments

Spring-to-close

⚠ WARNING Danger of life in case of improper disassembly. The maximum sum of the spring preload can be 60 000 N !

Disassembly instruction of the actuator subassembly

NOTICE For the disassembly, special tools such as a hydraulic spring press, stem wrench and stem clamping tool are necessary. Limit disassembly only to necessary components.

1. Fix the actuator on the assembly table, if this is not already happened.
2. Disassemble the hexagon bolts (335), plain washers (337) and hexagon nuts (351) from the casing (203).
3. Pull off the protection sleeve (339).

⚠ WARNING Risk of injury by jumping out parts ! Pre-loaded springs inside.

4. Lubricate the threads and loosen the long hexagon bolts (336), plain washers (337) and hexagon nuts (351) uniformly in a clockwise sequence as the springs expand.

NOTICE We recommend you to use a hydraulic spring press, as a minimum requirement threaded rods in 8.8 quality (ISO 898-1) or higher as well as washers and nuts alternatively.

5. Lift off the diaphragm casing (203, 258), distance plate (231) and spring adjusting plate (326).
6. Remove the actuator springs (229).
7. Fix the stem (211) with the stem clamping tool against twisting.
8. Loosen the special nut (348) counterclockwise and remove the lock washer (349), distance bushing (374), spacer bushing (228), disk (220), diaphragm plate (227), diaphragm (225), O-ring (272) and thrust washer (255).
9. Loosen the hexagon bolts (334) counterclockwise and remove the O-rings (279), diaphragm casing (202)

and O-ring (276).

10. Disassemble the hexagon bolts (335), plain washers (337) and hexagon nuts (351).
11. Pull off the protection sleeve (339).

⚠ WARNING Risk of injury by jumping out parts ! Pre-loaded springs inside.

12. Lubricate the threads and loosen the long hexagon bolts (336), plain washers (337) and hexagon nuts (351) uniformly in a clockwise sequence as the springs expand.

NOTICE We recommend you to use a hydraulic spring press, as a minimum requirement threaded rods in 8.8 quality (ISO 898-1) or higher as well as washers and nuts alternatively.

13. Lift off the diaphragm casing (202 - 373), distance plate (231) and spring adjusting plate (326).
14. Remove the actuator springs (229).
15. Remove the stem clamping tool.
16. Disassemble the coupling parts (see page 54).
17. Carefully pull out the diaphragm-stem unit (211 - 380).
18. Pull out the scraper ring (273) and O-rings (275, 2x).
19. Fix the diaphragm-stem unit into the stem clamping tool.
20. Loosen the stem extension (380) with the stem wrench counterclockwise and remove the lock washer (349), distance bushing (374), spacer bushing (228), disk (220), diaphragm plate (227), diaphragm (225), O-ring (272) and thrust washer (255).
21. Check stressed surface areas for damage such as scoring and deformities. Use a brass brush or similar tool to clean bolting. Check for corrosion or any other damage.

Reassembly instruction of the actuator subassembly

NOTICE Always replace parts showing wear with new parts.

22. Lubricate the new O-ring (275) and new scraper ring (273) with an appropriate lubricant and install into the guide bushing (253).
23. Lubricate the new O-ring (275) with an appropriate lubricant and install into the guide bushing (373).
24. Fix the stem (211) into the stem clamping tool.
25. Lubricate the new O-ring (272) with an appropriate lubricant.
26. Lower the thrust washer (255), O-ring (272), diaphragm (225), diaphragm plate (227), disk (220), spacer bushing (228), distance bushing (374) and lock washer (349) onto the stem (211).

NOTICE Arrange the distance bushing like an upside down top hat. Its function is that of an internal stroke stop.

27. Lubricate the thread of the stem (211) with an appropriate lubricant and install and finger tighten the stem extension (380).

NOTICE The diaphragm plate should be positioned to the diaphragm with the aid of the positioning template. Mark the position.

28. Turn clockwise the stem extension (380) using a suitable torque wrench, see section 15 torque requirements.
29. Loosen and remove the diaphragm-stem unit (211-380) out of the stem clamping tool. Lubricate the actuator stem with an appropriate lubricant.
30. Carefully lower the diaphragm-stem unit (211-380) into the diaphragm casing (202 - 334).

NOTICE Position the diaphragm-stem unit such that the air connection and the Mark align.

31. Install and align the actuator springs (229).

NOTICE The surface, respectively the edges of the spring ends should be aligned to the actuators center. If these will ignored the spring may touch the actuators casing and rub in rare cases.

32. Install and position the spring adjusting plate (326) such that the imprint on the plate and air connection are opposite of each other.
33. Install the distance plate (231) and diaphragm casing (202 - 374), positioning the casing such that the air connections opposites.
34. Lubricate the threats of the long hexagon bolts (336) with an appropriate lubricant and load the springs uniformly in a clockwise sequence by tightening the long hexagon bolts (336), plain washers (337) and hexagon nuts (351). Alternative method see *NOTICE* step 4.
35. Install the short hexagon bolts (335), plain washers (337) and hexagon nuts (351).
36. Tighten the nuts (351) using a crosswise pattern in four steps, see section 15 torque requirements.
37. Install the protection sleeve (339).
38. Assemble the coupling parts (see page 54).
39. Lubricate the new O-ring (276) with an appropriate lubricant and install it onto the guide bushing (373).
40. Lubricate the threats of the hexagon bolts (334) and the new O-rings (279) with an appropriate lubricant and install it onto the guide bushing (373). Tighten the bolts (334) using a crosswise pattern in two steps, see section 15 torque requirements.
41. Lubricate the new O-ring (272) with an appropriate lubricant.
42. Lower the thrust washer (255), O-ring (272), diaphragm (225), diaphragm plate (227), disk (220), spacer bushing (228), distance bushing (374) and lock washer (349) onto the stem (211).

NOTICE Arrange the distance bushing like an correctly wearing hat. The internal stroke stop takes over the special nut.

43. Lubricate the thread of the stem extension (348) with an appropriate lubricant and install and finger tighten the special nut (348).

NOTICE *The diaphragm plate should be positioned to the diaphragm with the aid of the positioning template. Mark the position.*

44. Fix the stem (211) with the stem clamping tool against twisting.

45. Turn the special nut (348) clockwise using a suitable torque wrench, see section 15 torque requirements.

46. Remove the stem clamping tool.

47. Install and align the actuator springs (229).

NOTICE *The surface, respectively the edges of the spring ends should be aligned to the actuators center. If these will ignored the spring may touch the actuators casing and rub in rare cases.*

48. Install and position the spring adjusting plate (326) such that the imprint on the plate and air connection are opposite of each other.

49. Install the distance plate (231) and diaphragm casing (203), positioning the casing such that the air connections opposites.

50. Lubricate the threats of the long hexagon bolts (336) with an appropriate lubricant and load the springs uniformly in a clockwise sequence by tightening the long hexagon bolts (336), plain washers (337) and hexagon nuts (351). Alternative method see *NOTICE* step 4.

51. Install the short hexagon bolts (335), plain washers (337) and hexagon nuts (351).

52. Tighten the nuts (351) using a crosswise pattern in four steps, see section 15 torque requirements.

53. Install the protection sleeve (339).

54. Perform 3 full strokes and check the tightening of the casing bolting.

55. Log the maintenance interval and the work performed.

56. The actuator subassembly is ready to be mounted on the valve and the accessories attached.

Item #		Part
WW	EU	
202	6.1	Diaphragm Casing
203	6.2	Diaphragm Casing
211	6.12	Stem
220	6.14	Disk (2x)
225	6.16	Diaphragm (2x)
227	6.15	Diaphragm Plate (2x)
228	6.13	Spacer Bushing (2x)
229	6.21	Actuator Spring
231	6.22	Distance Plate (2x)
253	6.8	Lower Guide Bushing
254	6.80	Plain Bearing (2x)
255	6.18	Thrust Washer (2x)
258	6.26	Vent Plug (2x)
272	6.17	O-Ring (2x)
273	6.11	Scraper Ring
275	6.10	O-Ring (2x)
276	6.9	O-Ring (3x)
279	6.46	O-Ring (18x)
326	6.23	Spring Adjusting Plate (2x)
334	6.45	Hexagon Bolt (18x)
335	6.3.1	Hexagon Bolt - short (40x) ¹⁾
336	6.3.2	Hexagon Bolt - long (8x) ¹⁾
337	6.5	Plain Washer (48x) ¹⁾
339	6.25	Protection Sleeve (8x)
348	6.20	Special Nut
349	6.19	Lock Washer (2x)
351	6.4	Hexagon Nut (48x)
373	6.82	Intermediate Guide Bushing
374	6.47	Distance Bushing (2x)
380	6.81	Stem Extension

¹⁾ Alternatively, hex head assembled screws with captive flat washers are used for this application.

Table 36: Actuator parts

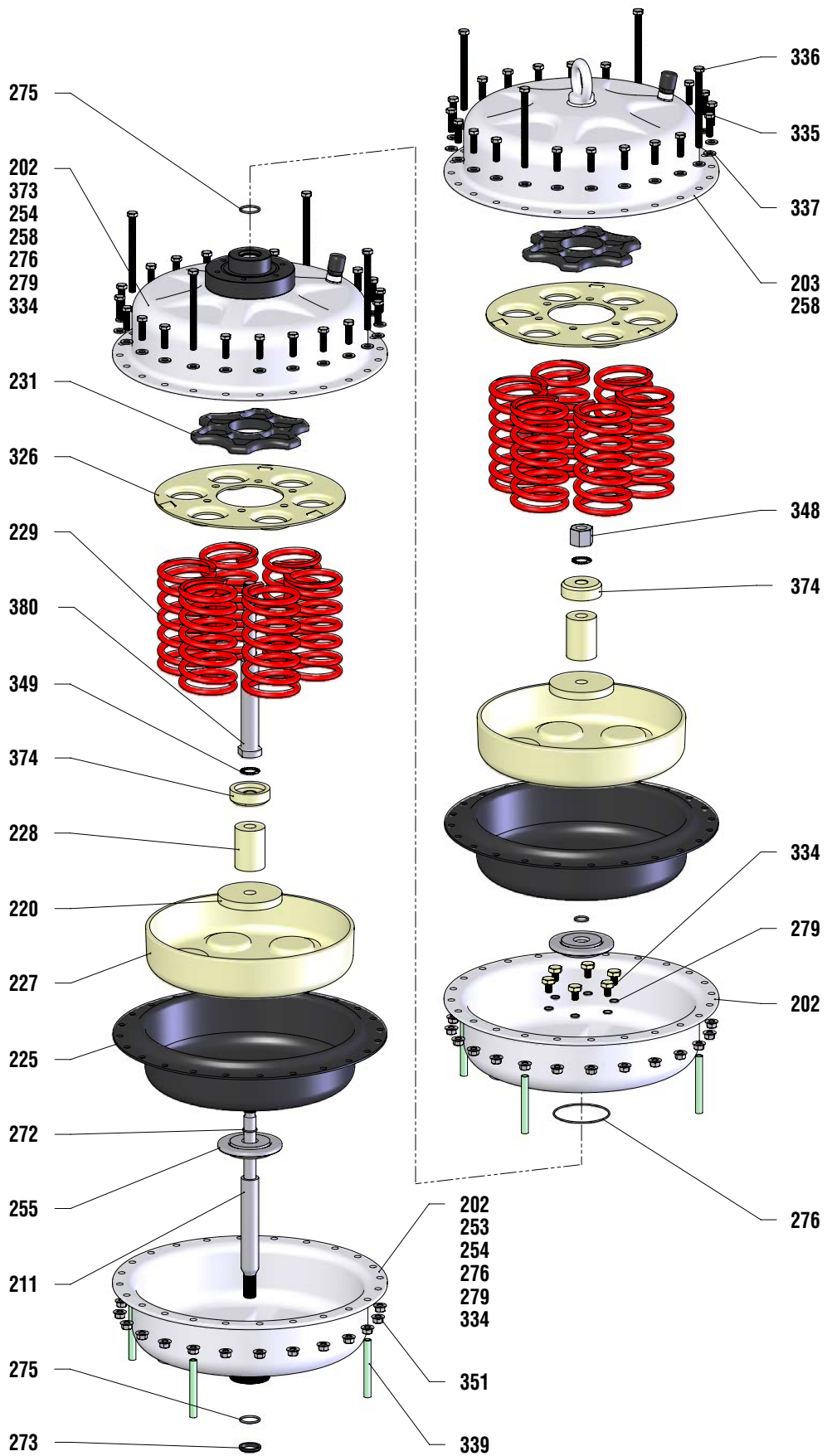

Figure 33: Actuator parts

Actuator without attachments

Spring-to-open

WARNING Danger of life in case of improper disassembly. The maximum sum of the spring preload can be 60 000 N !

Disassembly instruction of the actuator subassembly

NOTICE For the disassembly, special tools such as a hydraulic spring press, stem wrench and stem clamping tool are necessary. Limit disassembly only to necessary components.

1. Fix the actuator on the assembly table, if this is not already happened.
2. Disassemble the hexagon bolts (335), plain washers (337) and hexagon nuts (351) from the casing (203).
3. Pull off the protection sleeve (339).
4. Lubricate the threads and disassemble the hexagon bolts (336), plain washers (337) and hexagon nuts (351) counterclockwise.
5. Lift off the diaphragm casing (203, 258).
6. Fix the stem (211) with the stem clamping tool against twisting.

WARNING Risk of injury by jumping out parts ! Pre-loaded springs inside.

7. Loosen the special nut (348) counterclockwise and remove the lock washer (349), thrust washer (255), O-ring (272), diaphragm (225), diaphragm plate (227), disk (220), spacer bushing (228) and distance bushing (374).

NOTICE We recommend you to use a hydraulic spring press, as a minimum requirement a beam and threaded rods in 8.8 quality (ISO 898-1) or higher as well as washers and nuts alternatively.

8. Remove the actuator springs (229), spring adjusting plate (326) and distance plate (231).
9. Loosen the hexagon bolts (334) counterclockwise and

remove the O-rings (279), diaphragm casing (202) and O-ring (276).

10. Disassemble the hexagon bolts (335), plain washers (337) and hexagon nuts (351).
11. Pull off the protection sleeve (339).

WARNING Risk of injury by jumping out parts ! Pre-loaded springs inside.

12. Lubricate the threads and loosen the long hexagon bolts (336), plain washers (337) and hexagon nuts (351) uniformly in a clockwise sequence as the springs expand.

NOTICE We recommend you to use a hydraulic spring press, as a minimum requirement a threaded rods in 8.8 quality (ISO 898-1) or higher as well as washers and nuts alternatively.

13. Lift off the diaphragm casing (202 - 373).
14. Remove the stem clamping tool.
15. Disassemble the coupling parts (see page 54).
16. Carefully pull out the diaphragm-stem unit (211 - 380).
17. Remove the actuator springs (229), spring adjusting plate (326) and distance plate (231).
18. Fix the diaphragm-stem unit into the stem clamping tool.
19. Loosen the stem extension (380) with the stem wrench counterclockwise and remove the lock washer (349), thrust washer (255), O-ring (272), diaphragm (225), diaphragm plate (227), disk (220), spacer bushing (228) and distance bushing (374).
20. Pull out the scraper ring (273) and O-rings (275, 2x).
21. Check stressed surface areas for damage such as scoring and deformities. Use a brass brush or similar tool to clean bolting. Check for corrosion or any other damage.

Reassembly instruction of the actuator sub-assembly

NOTICE Always replace parts showing wear with new parts.

22. Lubricate the new O-ring (275) and new scraper ring (273) with an appropriate lubricant and install into the guide bushing (253).
23. Lubricate the new O-ring (275) with an appropriate lubricant and install into the guide bushing (373).
24. Fix the stem (211) into the stem clamping tool.
25. Lubricate the new O-ring (272) with an appropriate lubricant.
26. Lower the distance bushing (374), spacer bushing (228), disk (220), diaphragm plate (227), diaphragm (225), O-ring (272), thrust washer (255) and lock washer (349)

onto the stem (211).

NOTICE Arrange the distance bushing like an correctly wearing hat. Its function is that of an internal stroke stop.

27. Lubricate the thread of the stem (211) with an appropriate lubricant and install and finger tighten the stem extension (380).

NOTICE The diaphragm plate should be positioned to the diaphragm with the aid of the positioning template. Mark the position.

28. Turn clockwise the stem extension (380) using a suitable torque wrench, see section 15 torque requirements.
29. Install the distance plate (231) and positioning the spring adjusting plate (326) such that the imprint and air connection opposites.
30. Install and align the actuator springs (229).

NOTICE The surface, respectively the edges of the spring ends should be aligned to the actuators center. If these will ignored the spring may touch the actuators casing and rub in rare cases.

31. Loosen and remove the diaphragm-stem unit (211-380) out of the stem clamping tool. Lubricate the actuator stem with an appropriate lubricant.

32. Carefully lower the diaphragm-stem unit (211- 380) into the diaphragm casing (202 - 373).

NOTICE Position the diaphragm-stem unit such that the air connection and the Mark align.

33. Install the diaphragm casing (202 - 373), positioning the casing such that the air connections opposites.
34. Lubricate the threats of the long hexagon bolts (336) with an appropriate lubricant and load the springs uniformly in a clockwise sequence by tightening the long hexagon bolts (336), plain washers (337) and hexagon nuts (351). Alternative method see *NOTICE* step 12.
35. Install the short hexagon bolts (335), plain washers (337) and hexagon nuts (351).
36. Tighten the nuts (351) using a crosswise pattern in four steps, see section 15 torque requirements.
37. Install the protection sleeve (339).
38. Assemble the coupling parts (see page 54).
39. Lubricate the new O-ring (276) with an appropriate lubricant and install it onto the guide bushing (373).
40. Lubricate the threats of the hexagon bolts (334) and the new O-rings (279) with an appropriate lubricant.
41. Install the diaphragm casing (202) onto the guide bushing (373) and tighten the bolts (334) using a crosswise pattern in two steps, see section 15 torque requirements.
42. Install the distance plate (231) and positioning the spring adjusting plate (326) such that the imprint and air connection opposites.
43. Install and align the actuator springs (229).

NOTICE The surface, respectively the edges of the spring ends should be aligned to the actuators center. If these will ignored the spring may touch the actuators casing and rub in rare cases.

- 44. Lubricate the new O-ring (272) with an appropriate lubricant.
- 45. Lower the distance bushing (374), spacer bushing (228), disk (220), diaphragm plate (227), diaphragm (225), O-ring (272), thrust washer (255) and lock washer (349)

onto the stem extension (380).

NOTICE Arrange the distance bushing like an correctly wearing hat. The internal stroke stop takes over the special nut.

- 46. Lubricate the thread of the stem extension (380) with an appropriate lubricant.

NOTICE The diaphragm plate should be positioned to the diaphragm with the aid of the positioning template. Mark the position.

- 47. Fix the stem (211) with the stem clamping tool against twisting.
- 48. Load the springs by tightening the special nut (348) clockwise using a suitable torque wrench, see section 15 torque requirements.

NOTICE We recommend you to use a hydraulic spring press, as a minimum requirement a beam and threaded rods in 8.8 quality (ISO 898-1) or higher as well as washers and nuts alternatively.

- 49. Remove the stem clamping tool.
- 50. Install the diaphragm casing (203), positioning the casing such that the air connections opposites.
- 51. Lubricate the threats of the long hexagon bolts (336) with an appropriate lubricant and load the springs uniformly in a clockwise sequence by tightening the long hexagon bolts (336), plain washers (337) and hexagon nuts (351).
- 52. Install the short hexagon bolts (335), plain washers (337) and hexagon nuts (351).
- 53. Tighten the nuts (351) using a crosswise pattern in four steps, see section 15 torque requirements.
- 54. Install the protection sleeve (339).
- 55. Perform 3 full strokes and check the tightening of the casing bolting.

- 56. Log the maintenance interval and the work performed.
- 57. The actuator subassembly is ready to be mounted on the valve and the accessories attached.

Item #		Part
WW	EU	
202	6.1	Diaphragm Casing
203	6.2	Diaphragm Casing
211	6.12	Stem
220	6.14	Disk (2x)
225	6.16	Diaphragm (2x)
227	6.15	Diaphragm Plate (2x)
228	6.13	Spacer Bushing (2x)
229	6.21	Actuator Spring
231	6.22	Distance Plate (2x)
253	6.8	Lower Guide Bushing
254	6.80	Plain Bearing (2x)
255	6.18	Thrust Washer (2x)
258	6.26	Vent Plug (2x)
272	6.17	O-Ring (2x)
273	6.11	Scraper Ring
275	6.10	O-Ring (2x)
276	6.9	O-Ring (3x)
279	6.46	O-Ring (18x)
326	6.23	Spring Adjusting Plate (2x)
334	6.45	Hexagon Bolt (18x)
335	6.3.1	Hexagon Bolt - short (40x) ¹⁾
336	6.3.2	Hexagon Bolt - long (8x) ¹⁾
337	6.5	Plain Washer (48x) ¹⁾
339	6.25	Protection Sleeve (8x)
348	6.20	Special Nut
349	6.19	Lock Washer (2x)
351	6.4	Hexagon Nut (48x)
373	6.82	Intermediate Guide Bushing
374	6.47	Distance Bushing (2x)
380	6.81	Stem Extension

¹⁾ Alternatively, hex head assembled screws with captive flat washers are used for this application.

Table 37: Actuator parts

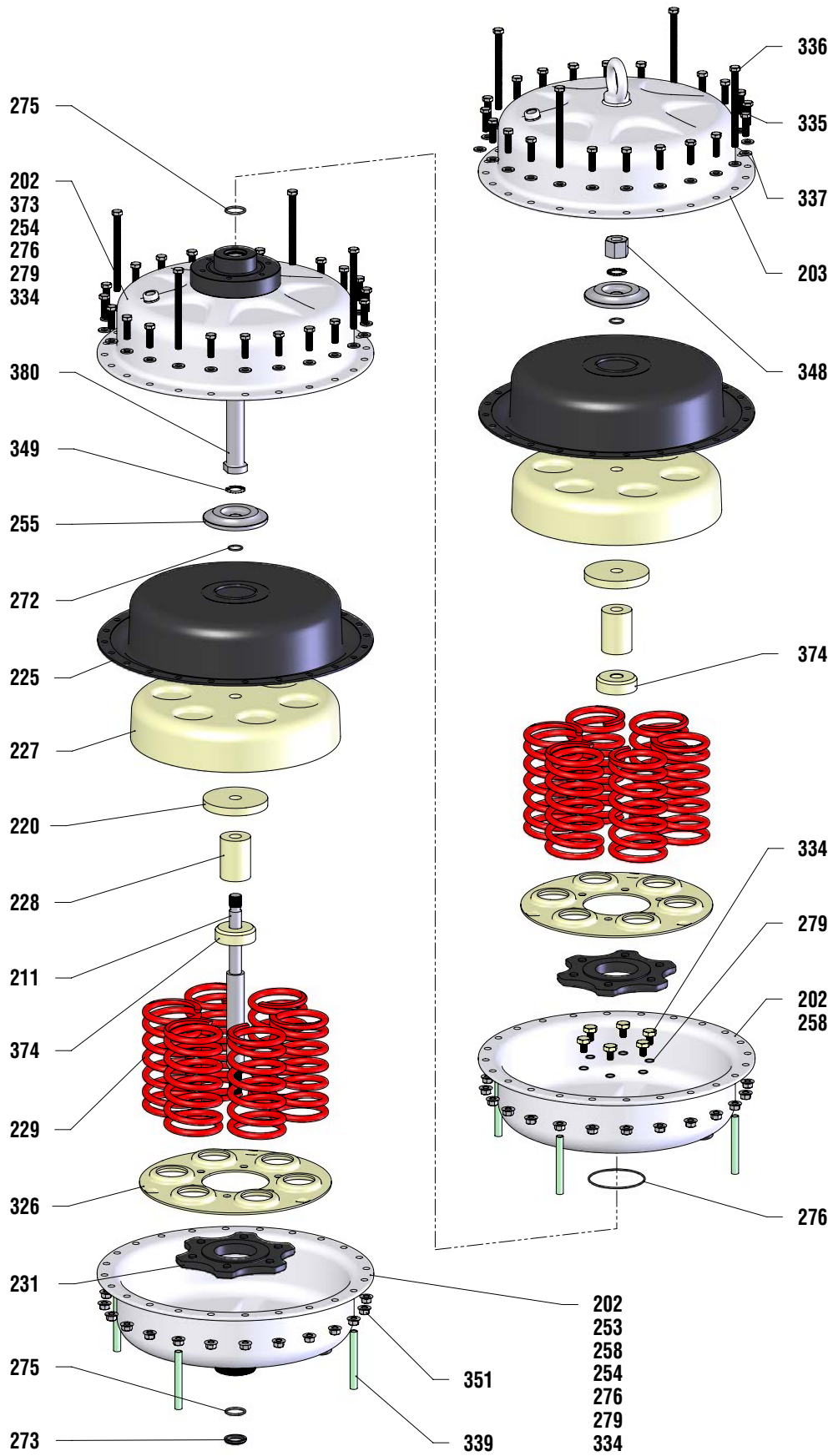

Figure 34: Actuator parts

Actuator with attachments

Spring-to-close

⚠ WARNING Danger of life in case of improper disassembly. The maximum sum of the spring preload can be 60 000 N !

Disassembly instruction of the actuator subassembly

NOTICE For the disassembly, special tools such as a hydraulic spring press, stem wrench and stem clamping tool are necessary. Limit disassembly only to necessary components.

1. Fix the actuator on the assembly table, if this is not already happened.
2. Disassemble the hexagon bolts (335), plain washers (337) and hexagon nuts (351) from the casing (203).
3. Pull off the protection sleeve (339).

⚠ WARNING Risk of injury by jumping out parts ! Pre-loaded springs inside.

4. Lubricate the threads and loosen the long hexagon bolts (336), plain washers (337) and hexagon nuts (351) uniformly in a clockwise sequence as the springs expand.

NOTICE We recommend you to use a hydraulic spring press, as a minimum requirement threaded rods in 8.8 quality (ISO 898-1) or higher as well as washers and nuts alternatively.

5. Lift off the diaphragm casing (203 - 389), distance plate (231) and spring adjusting plate (326).
6. Remove the actuator springs (229).
7. Fix the stem (211) with the stem clamping tool against twisting.
8. Loosen the stem (348) with the stem wrench counterclockwise and remove the lock washer (349), distance bushing (374), spacer bushing (228), disk (220), diaphragm plate (227), diaphragm (225), O-ring (272) and thrust washer (255).
9. Loosen the hexagon bolts (334) counterclockwise and remove the O-rings (279), diaphragm casing (202)

and O-ring (276).

10. Disassemble the hexagon bolts (335), plain washers (337) and hexagon nuts (351).
11. Pull off the protection sleeve (339).

⚠ WARNING Risk of injury by jumping out parts ! Pre-loaded springs inside.

12. Lubricate the threads and loosen the long hexagon bolts (336), plain washers (337) and hexagon nuts (351) uniformly in a clockwise sequence as the springs expand.

NOTICE We recommend you to use a hydraulic spring press, as a minimum requirement threaded rods in 8.8 quality (ISO 898-1) or higher as well as washers and nuts alternatively.

13. Lift off the diaphragm casing (202 - 373), distance plate (231) and spring adjusting plate (326).
14. Remove the actuator springs (229).
15. Remove the stem clamping tool.
16. Disassemble the coupling parts (see page 54).
17. Carefully pull out the diaphragm-stem unit (211 - 380).
18. Pull out the scraper ring (273) and O-rings (275, 3x).
19. Fix the diaphragm-stem unit into the stem clamping tool.
20. Loosen the stem extension (380) with the stem wrench counterclockwise and remove the lock washer (349), distance bushing (374), spacer bushing (228), disk (220), diaphragm plate (227), diaphragm (225), O-ring (272) and thrust washer (255).
21. Check stressed surface areas for damage such as scoring and deformities. Use a brass brush or similar tool to clean bolting. Check for corrosion or any other damage.

Reassembly instruction of the actuator subassembly

NOTICE Always replace parts showing wear with new parts.

22. Lubricate the new O-ring (275) and new scraper ring (273) with an appropriate lubricant and install into the guide bushing (253).
23. Lubricate the new O-ring (275) with an appropriate lubricant and install into the guide bushing (6.82).
24. Fix the stem (211) into the stem clamping tool.
25. Lubricate the new O-ring (272) with an appropriate lubricant.
26. Lower the thrust washer (255), O-ring (272), diaphragm (225), diaphragm plate (227), disk (220), spacer bushing (228), distance bushing (374) and lock washer (349)

onto the stem (211).

NOTICE Arrange the distance bushing like an upside down top hat. Its function is that of an internal stroke stop.

27. Lubricate the thread of the stem (211) with an appropriate lubricant and install and finger tighten the stem extension (380).

NOTICE The diaphragm plate should be positioned to the diaphragm with the aid of the positioning template. Mark the position.

28. Turn clockwise the stem extension (380) using a suitable torque wrench, see section 15 torque requirements.
29. Loosen and remove the diaphragm-stem unit (211 - 380) out of the stem clamping tool. Lubricate the actuator stem with an appropriate lubricant.
30. Carefully lower the diaphragm-stem unit (211 - 380) into the diaphragm casing (202 - 373).

NOTICE Position the diaphragm-stem unit such that the air connection and the Mark align.

31. Install and align the actuator springs (229).

NOTICE The surface, respectively the edges of the spring ends should be aligned to the actuators center. If these will ignored the spring may touch the actuators casing and rub in rare cases.

32. Install and position the spring adjusting plate (326) such that the imprint on the plate and air connection are opposite of each other.
33. Install the distance plate (231) and diaphragm casing (202 - 389), positioning the casing such that the air connections opposites.
34. Lubricate the threats of the long hexagon bolts (336) with an appropriate lubricant and load the springs uniformly in a clockwise sequence by tightening the long hexagon bolts (336), plain washers (337) and hexagon nuts (351). Alternative method see *NOTICE* step 4.
35. Install the short hexagon bolts (335), plain washers (337) and hexagon nuts (351).
36. Tighten the nuts (351) using a crosswise pattern in four steps, see section 15 torque requirements.
37. Install the protection sleeve (339).
38. Assemble the coupling parts (see page 54).
39. Lubricate the new O-ring (276) with an appropriate lubricant and install it onto the guide bushing (373).
40. Lubricate the threats of the hexagon bolts (334) and the new O-rings (279) with an appropriate lubricant and install it onto the guide bushing (373). Tighten the bolts (334) using a crosswise pattern in two steps, see section 15 torque requirements.
41. Lubricate the new O-ring (272) with an appropriate lubricant.
42. Lower the thrust washer (255), O-ring (272), diaphragm (225), diaphragm plate (227), disk (220), spacer bushing (228), distance bushing (374) and lock washer

onto the stem (211).

NOTICE Arrange the distance bushing like an correctly wearing hat. The internal stroke stop takes over the special nut.

43. Lubricate the thread of the stem extension (380) with an appropriate lubricant and install and finger tighten the stem (348).

NOTICE *The diaphragm plate should be positioned to the diaphragm with the aid of the positioning template. Mark the position.*

44. Fix the stem (211) with the stem clamping tool against twisting.

45. Turn clockwise the stem (348) using a suitable torque wrench, see section 15 torque requirements.

46. Remove the stem clamping tool.

47. Install and align the actuator springs (229).

NOTICE *The surface, respectively the edges of the spring ends should be aligned to the actuators center. If these will ignored the spring may touch the actuators casing and rub in rare cases.*

48. Install and position the spring adjusting plate (326) such that the imprint on the plate and air connection are opposite of each other.

49. Install the distance plate (231) and diaphragm casing (203), positioning the casing such that the air connections opposites.

50. Lubricate the threats of the long hexagon bolts (336) with an appropriate lubricant and load the springs uniformly in a clockwise sequence by tightening the long hexagon bolts (336), plain washers (337) and hexagon nuts (351). Alternative method see *NOTICE* step 4.

51. Install the short hexagon bolts (335), plain washers (337) and hexagon nuts (351).

52. Tighten the nuts (351) using a crosswise pattern in four steps, see section 15 torque requirements.

53. Install the protection sleeve (339).

54. Perform 3 full strokes and check the tightening of the casing bolting.

55. Log the maintenance interval and the work performed.

56. The actuator subassembly is ready to be mounted on the valve and the accessories attached.

Item #		Part
WW	EU	
202	6.1	Diaphragm Casing (4x)
211	6.12	Stem
220	6.14	Disk (2x)
225	6.16	Diaphragm (2x)
227	6.15	Diaphragm Plate (2x)
228	6.13	Spacer Bushing (2x)
229	6.21	Actuator Spring
231	6.22	Distance Plate (2x)
253	6.8	Lower Guide Bushing
254	6.80	Plain Bearing (3x)
255	6.18	Thrust Washer (2x)
258	6.26	Vent Plug (2x)
272	6.17	O-Ring (2x)
273	6.11	Scraper Ring (2x)
275	6.10	O-Ring (3x)
276	6.9	O-Ring (4x)
279	6.46	O-Ring (24x)
326	6.23	Spring Adjusting Plate (2x)
334	6.45	Hexagon Bolt (24x)
335	6.3.1	Hexagon Bolt - short (40x)
336	6.3.2	Hexagon Bolt - long (8x)
337	6.5	Plain Washer (48x) ¹⁾
339	6.25	Protection Sleeve (8x)
348	6.20	Stem
349	6.19	Lock Washer (2x)
351	6.4	Hexagon Nut (48x)
373	6.82	Intermediate Guide Bushing
374	6.47	Distance Bushing (2x)
380	6.81	Stem Extension
389	6.83	Upper Guide Bushing

¹⁾ Alternatively, hex head assembled screws with captive flat washers are used for this application.

Table 38: Actuator parts

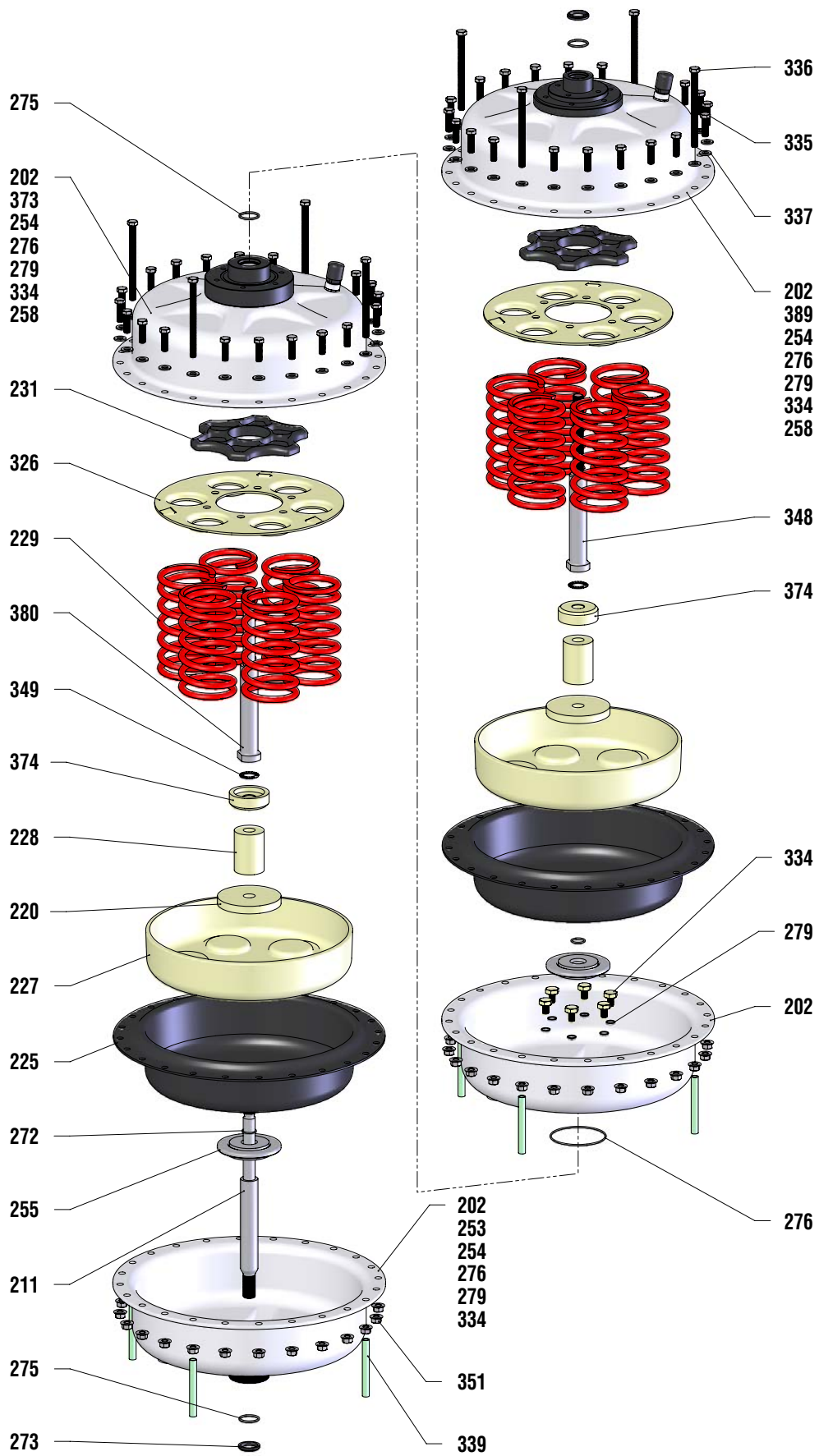

Figure 35: Actuator parts

Actuator with attachments

Spring-to-open

⚠ WARNING Danger of life in case of improper disassembly. The maximum sum of the spring preload can be 60 000 N !

Disassembly instruction of the actuator subassembly

NOTICE For the disassembly, special tools such as a hydraulic spring press, stem wrench and stem clamping tool are necessary. Limit disassembly only to necessary components.

1. Fix the actuator on the assembly table, if this is not already happened.
2. Disassemble the hexagon bolts (335), plain washers (337) and hexagon nuts (351) from the casing (203).
3. Pull off the protection sleeve (339).
4. Lubricate the threads and disassemble the hexagon bolts (336), plain washers (337) and hexagon nuts (351) counterclockwise.
5. Lift off the diaphragm casing (202 - 389).
6. Fix the stem (211) with the stem clamping tool against twisting.

⚠ WARNING Risk of injury by jumping out parts ! Pre-loaded springs inside.

7. Loosen the stem (348) counterclockwise and remove the lock washer (349), thrust washer (255), O-ring (272), diaphragm (225), diaphragm plate (227), disk (220), spacer bushing (228) and distance bushing (374).

NOTICE We recommend you to use a hydraulic spring press, as a minimum requirement a beam and threaded rods in 8.8 quality (ISO 898-1) or higher as well as washers and nuts alternatively.

8. Remove the actuator springs (229), spring adjusting plate (326) and distance plate (231).

9. Loosen the hexagon bolts (334) counterclockwise and remove the O-rings (279), diaphragm casing (202) and O-ring (276).
10. Disassemble the hexagon bolts (335), plain washers (337) and hexagon nuts (351).
11. Pull off the protection sleeve (339).

⚠ WARNING Risk of injury by jumping out parts ! Pre-loaded springs inside.

12. Lubricate the threads and loosen the long hexagon bolts (336), plain washers (337) and hexagon nuts (351) uniformly in a clockwise sequence as the springs expand.

NOTICE We recommend you to use a hydraulic spring press, as a minimum requirement a threaded rods in 8.8 quality (ISO 898-1) or higher as well as washers and nuts alternatively.

13. Lift off the diaphragm casing (202 - 373).
14. Remove the stem clamping tool.
15. Disassemble the coupling parts (see page 54).
16. Carefully pull out the diaphragm-stem unit (211 - 380).
17. Remove the actuator springs (229), spring adjusting plate (326) and distance plate (231).
18. Fix the diaphragm-stem unit into the stem clamping tool.
19. Loosen the stem extension (380) with the stem wrench counterclockwise and remove the lock washer (349), thrust washer (255), O-ring (272), diaphragm (225), diaphragm plate (227), disk (220), spacer bushing (228) and distance bushing (374).
20. Pull out the scraper ring (273) and O-rings (275, 3x).
21. Check stressed surface areas for damage such as scoring and deformities. Use a brass brush or similar tool to clean bolting. Check for corrosion or any other damage.

Reassembly instruction of the actuator sub-assembly

NOTICE Always replace parts showing wear with new parts.

22. Lubricate the new O-ring (275) and new scraper ring (273) with an appropriate lubricant and install into the guide bushing (253).
23. Lubricate the new O-ring (275) with an appropriate lubricant and install into the guide bushing (373).
24. Fix the stem (211) into the stem clamping tool.
25. Lubricate the new O-ring (272) with an appropriate lubricant.
26. Lower the distance bushing (374), spacer bushing (228), disk (220), diaphragm plate (227), diaphragm (225), O-ring (272), thrust washer (255) and lock washer (349)

onto the stem (211).

NOTICE Arrange the distance bushing like an correctly wearing hat. Its function is that of an internal stroke stop.

27. Lubricate the thread of the stem (211) with an appropriate lubricant and install and finger tighten the stem extension (380).

NOTICE The diaphragm plate should be positioned to the diaphragm with the aid of the positioning template. Mark the position.

28. Turn clockwise the stem extension (380) using a suitable torque wrench, see section 15 torque requirements.
29. Install the distance plate (231) and positioning the spring adjusting plate (326) such that the imprint and air connection opposites.
30. Install and align the actuator springs (229).

NOTICE The surface, respectively the edges of the spring ends should be aligned to the actuators center. If these will ignored the spring may touch the actuators casing and rub in rare cases.

31. Loosen and remove the diaphragm-stem unit (211-380) out of the stem clamping tool. Lubricate the actuator stem with an appropriate lubricant.

32. Carefully lower the diaphragm-stem unit (211- 380) into the diaphragm casing (202 - 334).

NOTICE Position the diaphragm-stem unit such that the air connection and the Mark align.

33. Install the diaphragm casing (202 - 373), positioning the casing such that the air connections opposites.
34. Lubricate the threats of the long hexagon bolts (336) with an appropriate lubricant and load the springs uniformly in a clockwise sequence by tightening the long hexagon bolts (336), plain washers (337) and hexagon nuts (351). Alternative method see *NOTICE* step 12.
35. Install the short hexagon bolts (335), plain washers (337) and hexagon nuts (351).
36. Tighten the nuts (351) using a crosswise pattern in four steps, see section 15 torque requirements.
37. Install the protection sleeve (339).
38. Assemble the coupling parts (see page 54).
39. Lubricate the new O-ring (276) with an appropriate lubricant and install it onto the guide bushing (373).
40. Lubricate the threats of the hexagon bolts (334) and the new O-rings (279) with an appropriate lubricant.
41. Install the diaphragm casing (202) onto the guide bushing (373) and tighten the bolts (334) using a crosswise pattern in two steps, see section 15 torque requirements.
42. Install the distance plate (231) and positioning the spring adjusting plate (326) such that the imprint and air connection opposites.
43. Install and align the actuator springs (229).

NOTICE The surface, respectively the edges of the spring ends should be aligned to the actuators center. If these will ignored the spring may touch the actuators casing and rub in rare cases.

- 44. Lubricate the new O-ring (272) with an appropriate lubricant.
- 45. Lower the distance bushing (374), spacer bushing (228), disk (220), diaphragm plate (227), diaphragm (225), O-ring (272), thrust washer (255) and lock washer (349)

onto the stem extension (6.81).

NOTICE *Arrange the distance bushing like an correctly wearing hat. The internal stroke stop takes over the special nut.*

- 46. Lubricate the thread of the stem extension (380) with an appropriate lubricant.

NOTICE *The diaphragm plate should be positioned to the diaphragm with the aid of the positioning template. Mark the position.*

- 47. Fix the stem (211) with the stem clamping tool against twisting.
- 48. Load the springs by tightening the stem (348) clockwise using a suitable torque wrench, see section 15 torque requirements.

NOTICE *We recommend you to use a hydraulic spring press, as a minimum requirement a beam and threaded rods in 8.8 quality (ISO 898-1) or higher as well as washers and nuts alternatively.*

- 49. Remove the stem clamping tool.
- 50. Install the diaphragm casing (203), positioning the casing such that the air connections opposites.
- 51. Lubricate the threats of the long hexagon bolts (336) with an appropriate lubricant and load the springs uniformly in a clockwise sequence by tightening the long hexagon bolts (336), plain washers (337) and hexagon nuts (351).
- 52. Install the short hexagon bolts (335), plain washers (337) and hexagon nuts (351).
- 53. Tighten the nuts (351) using a crosswise pattern in four steps, see section 15 torque requirements.
- 54. Install the protection sleeve (339).
- 55. Perform 3 full strokes and check the tightening of the casing bolting.

- 56. Log the maintenance interval and the work performed.
- 57. The actuator subassembly is ready to be mounted on the valve and the accessories attached.

Item #		Part
WW	EU	
202	6.1	Diaphragm Casing (4x)
211	6.12	Stem
220	6.14	Disk (2x)
225	6.16	Diaphragm (2x)
227	6.15	Diaphragm Plate (2x)
228	6.13	Spacer Bushing (2x)
229	6.21	Actuator Spring
231	6.22	Distance Plate (2x)
253	6.8	Lower Guide Bushing
254	6.80	Plain Bearing (3x)
255	6.18	Thrust Washer (2x)
258	6.26	Vent Plug (2x)
272	6.17	O-Ring (2x)
273	6.11	Scraper Ring
275	6.10	O-Ring (3x)
276	6.9	O-Ring (4x)
279	6.46	O-Ring (24x)
326	6.23	Spring Adjusting Plate (2x)
334	6.45	Hexagon Bolt (24x)
335	6.3.1	Hexagon Bolt - short (40x)
336	6.3.2	Hexagon Bolt - long (8x)
337	6.5	Plain Washer (48x) ¹⁾
339	6.25	Protection Sleeve (8x)
348	6.20	Stem
349	6.19	Lock Washer (2x)
351	6.4	Hexagon Nut (48x)
373	6.82	Intermediate Guide Bushing
374	6.47	Distance Bushing (2x)
380	6.81	Stem Extension
389	6.83	Upper Guide Bushing

¹⁾ Alternatively, hex head assembled screws with captive flat washers are used for this application.

Table 39: Actuator parts

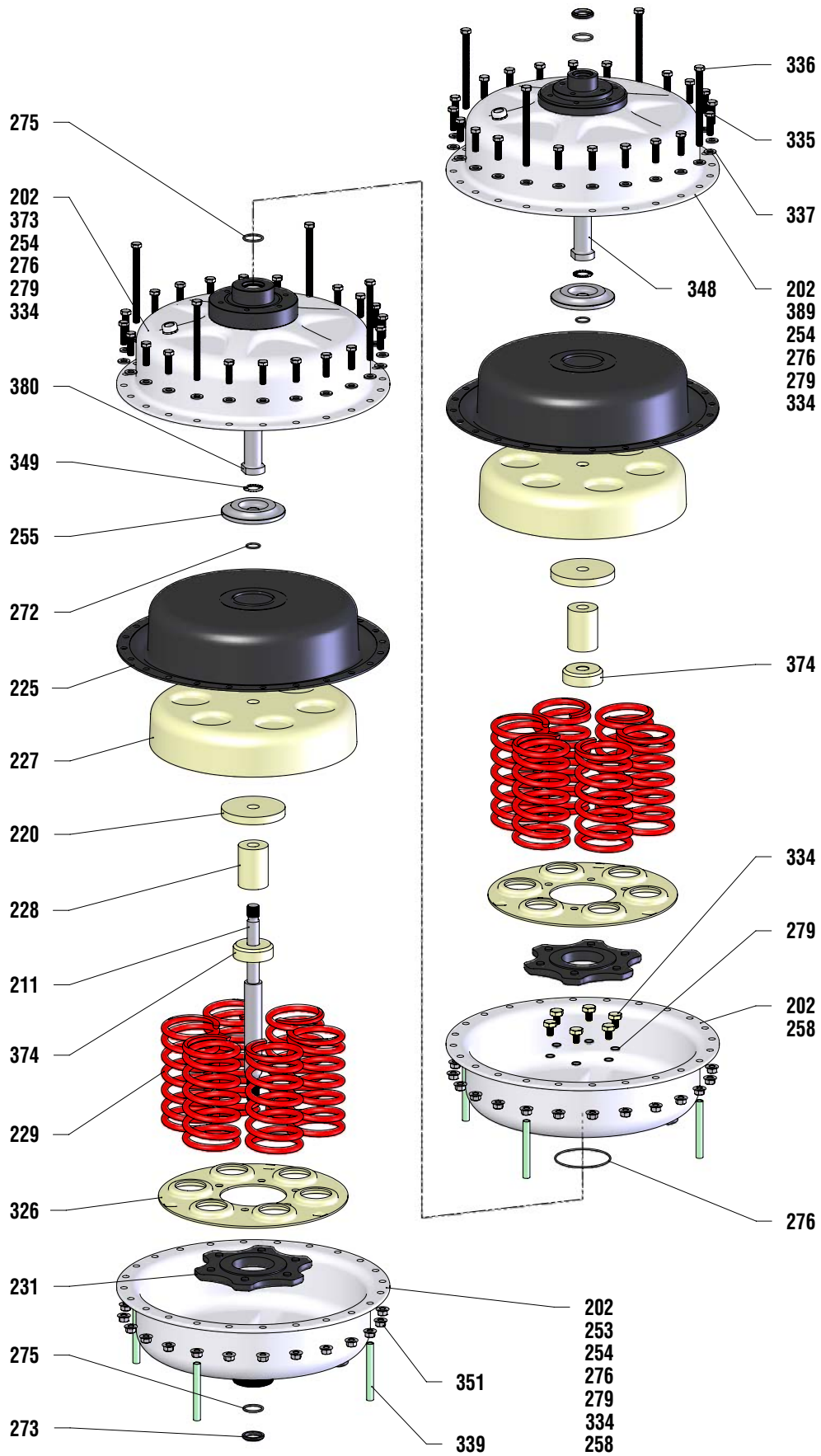

Figure 36: Actuator parts

16 Torque Requirements

Torque Requirements for VALVE / ACTUATOR LOCK NUT (76, 256) per actuator size					
Unit	253	503	701	1502	3002
Nm	Tighten the lock nut clockwise with a rounded chisel and a 1,5 kg (3.5 lbs) hammer before occurs the kickback effect.				
ft lb					

Torque Requirements for COUPLING PARTS (345, 113, 249, 344, 240, 420, 214) per actuator size					
Unit	253	503	701	1502	3002
Nm	Tighten the subordinate bolting properly by hand in accordance with the relevant technical standards.				
ft lb					

Torque Requirements for HEXAGON BOLT (334) per actuator size					
Unit	253	503	701	1502	3002
Nm	n.n.			45	
ft lb				33	

Torque Requirements for SPECIAL NUT / STEM EXTENSION & STEM (348, 380) per actuator size					
Unit	253	503	701	1502	3002
Nm	45	110		240	
ft lb	33	81		177	

Torque Requirements for CASING BOLTING (335 & 351 and 336 & 351, 209) per actuator size					
Unit	253	503	701	1502	3002
Nm				20	
ft lb				15	

Torque Requirements for HEXAGON BOLTS (150) per actuator size					
Unit	253	503	701	1502	3002
Nm	15	25			n.n.
ft lb	11	18			

17 Lubricants

Use		Lubricant / Antiseize	
		WW (World Wide)	EU (European Union)
Standard, from -40°C to +80°C -40°F to +176°F	Actuator O-Ring's (237, 247)	DOW Molykote 55 O-Ring	Klüber Unisilikon L 250 L
	Threads of the Actuator (107, 211, 250, 330, 334, 335, 336, 365) and Guide (247, 358)	Fastorq A/G	Klüberpaste 46 MR 401
Low temperature, from -60°C to -41°C -76°F to -40°F	Actuator O-Ring's (237, 247) and Guide (247, 358)	Alcohol 96%	
	Threads of the Actuator (107, 211, 250, 330, 334, 335, 336, 365)	Fastorq A/G	Klüberpaste 46 MR 401

18 Disposal

Up to 95 % of the FlowAct pneumatic actuator is metal. The remaining materials are synthetic, rubber, polycarbonate (PC), silicone, paint and lubricants.

NOTICE *Potential hazards and their sources are under the operator's influence. The operator must observe national and international environmental conditions for rotary actuator removal from the pipeline and cleaning. Permissible limit values must be maintained to ensure suitable protective measures; service personnel must be properly instructed in performing the disassembly and reassembly procedure.*

The valve should be professionally disassembled and reassembled. Metal parts should be scrapped, with the remaining materials disposed of according to the national conditions.

Peripheral units (accessories) should be recycled according to the relevant manufacturer's User Instructions.



FCD VLENIMFACTA4 10/16 Printed in Europe

To find your local Flowserve representative
or for more information about Flowserve Corporation, visit
www.flowserve.com.

Flowserve Corporation has established industry leadership in the design and manufacture of its products. When properly selected, this Flowserve product is designed to perform its intended function safely during its useful life. However, the purchaser or user of Flowserve products should be aware that Flowserve products might be used in numerous applications under a wide variety of industrial service conditions. Although Flowserve can (and often does) provide general guidelines, it cannot provide specific data and warnings for all possible applications. The purchaser/user must therefore assume the ultimate responsibility for the proper sizing and selection, installation, operation, and maintenance of Flowserve products. The purchaser/user should read and understand the Installation Operation Maintenance (IOM) instructions included with the product, and train its employees and contractors in the safe use of Flowserve products in connection with the specific application.

While the information and specifications contained in this literature are believed to be accurate, they are supplied for informative purposes only and should not be considered certified or as a guarantee of satisfactory results by reliance thereon. Nothing contained herein is to be construed as a warranty or guarantee, express or implied, regarding any matter with respect to this product. Because Flowserve is continually improving and upgrading its product design, the specifications, dimensions and information contained herein are subject to change without notice. Should any question arise concerning these provisions, the purchaser/user should contact Flowserve Corporation at any one of its worldwide operations or offices.

© 2004 Flowserve Corporation, Irving, Texas, USA. Flowserve is a registered trademark of Flowserve Corporation.

USA

Flowserve Flow Control Division
1350 N. Mt. Springs Parkway
Springville, UT 84663

USA

Phone: +1 801 489 8611

Fax: +1 801 489 3719

Austria

Flowserve Control Valves GmbH
Kasernengasse 6
9500 Villach

AUSTRIA

Phone: +43 (0) 4242 41181 - 0

Fax: +43 (0) 4242 41181 - 50

France

Flowserve France S.A.S
PB 60 63307 Thiers Cedex
FRANCE

Phone: +33 4738 04266

Fax: +33 4738 01424

India

Flowserve India Controls Pvt Ltd.
Plot # 4, 1A, Road #8 EPIP White-
field Bangalore, Karnataka, 560066

INDIA

Phone: 91 80 40146200

Fax: 91 80 28410286

China

Flowserve Fluid Motion and
Control (Suzhou) Co., Ltd.

No. 35, Baiyu Road,
Suzhou Industrial Park,
Suzhou Jiangsu Province,
P.R. 215021 CHINA

Phone: 86 512 6288 8790

Fax: 86 512 6288 8736

Singapore

Flowserve Pte. Ltd.
12 Tuas Avenue 20
Republic of Singapore 638824
SINGAPORE

Phone: +65 6879 8900

Fax: +65 6862 4940

Saudi Arabia

Flowserve Abahsain Flow Control Co.,
Ltd.

Makkah Road, Phase 4
Plot 10 & 12, 2nd Industrial City
Dammam, Kingdom of Saudi Arabia

Phone: +966 3 857 3150 X 243

Fax: +966 3 857 4243