

***Valtek FlowAct - adaption for Mark One***

***High Performance Actuator***

250 - 1500 cm<sup>2</sup>, 0,5 - 60 kN

FCD VLENTB0400-01 03/17





## FlowAct - Features

### Application

For installation on control valves, direct or reverse action, for throttling or on/off operation.

### Product features

- Multi-spring compact design
- Radial spring arrangement permits a low mounting height
- Low volume between diaphragm and case gives fast response times
- Strong operating force by permissible pressure supply up to 6 bar / 87 psig
- Permissible ambient temperature -40 up to 80°C / -40 up to 176°F, operating in the limits temporarily allowed otherwise lifetime will be reduced
- Stable guided actuator stem
- Fabric-reinforced, roll-type diaphragm with minimum area variation allowing linearity to be maintained throughout various stroke positions - even upon loss of operating forces.
- Stem bushing requires no maintenance
- Stable yoke in spheroidal cast ductile iron
- Positioner direct mounting without tubing (spring to close)
- Central mounting on the control valve
- Yoke and stem coupling with mounting surfaces according to NAMUR (DIN IEC 65 B CO)
- Top and side-mounted handwheels
- SIL 3 capable

### Operation

The diaphragm is actuated by the air supply 0,2 - 1,0 bar with a pneumatic positioner. The actuator stem moves as soon as the diaphragm force exceeds the counterforce of the springs. There are two operational modes depending on the arrangement of the spring package:

1. Stem extends by air failure
2. Stem retracts by air failure

The control valve can be opened or closed with a rising signal. On air failure, the actuator is set back to the zero position by spring force (fail-safe-position).

**Quality assurance system certificated acc. EN ISO 9001 : 2000 including product development.**

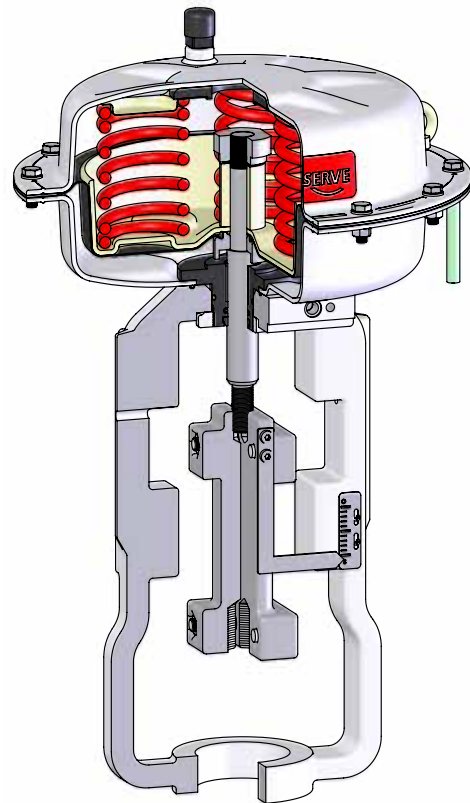

Stem extends by air failure

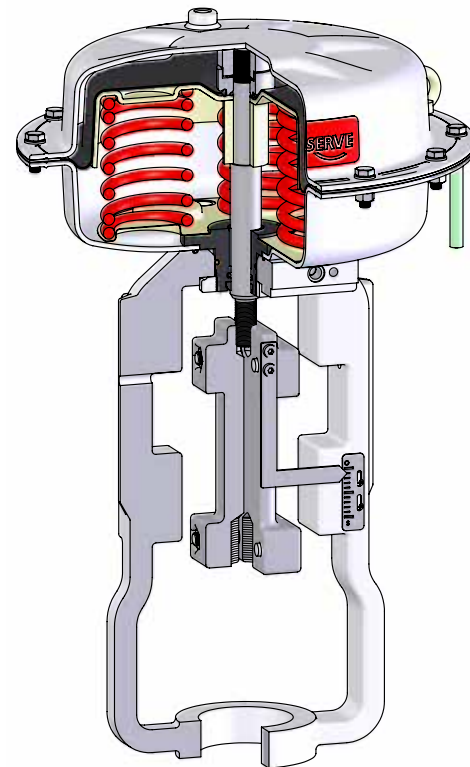

Stem retracts by air failure

Design / Code	Yoke Code	Size / Code		Hand wheel	Model
I	M	250 500 700	<b>253</b> <b>503</b> <b>701</b>	without Code O	
I	M	250 500	<b>253</b> <b>503</b>	light Code L	
I	M	250 500 700	<b>253</b> <b>503</b> <b>701</b>	heavy Code H	
I	M	250 500 700	<b>253</b> <b>503</b> <b>701</b>	side Code S	

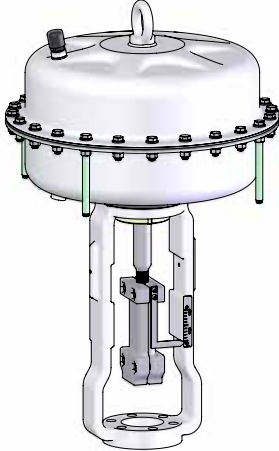
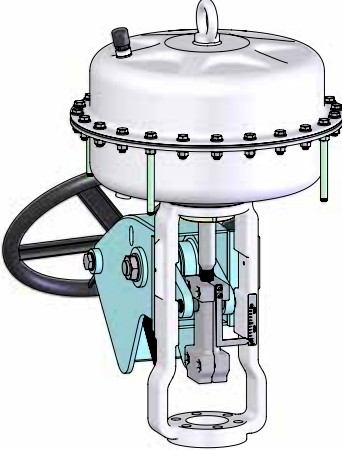
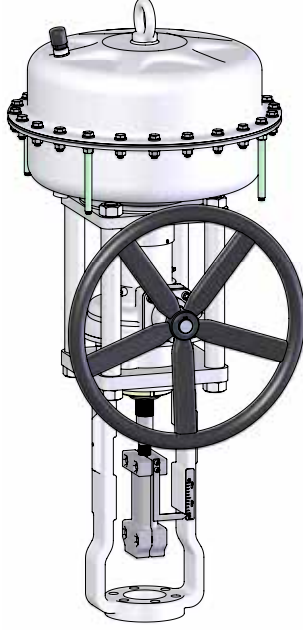
Design / Code	Yoke Code	Size / Code		Hand wheel	Model
P	M	1500	1502	without Code <b>O</b>	
P	M	1500	1502	side <sup>1)</sup> Code <b>S</b>	
P	M	1500	1502	central Code <b>Z</b>	

<sup>1)</sup> The side-mounted handwheel is designed for 39 kN. Note that the hand forces for the pneumatic actuator exceed hand forces for manually operated valves !

## Positioning Force for Actuator Size - 250 to 500 ( DIN )

Effective Area		Stroke		Spring Range		Stem extends by Air failure			Stem retracts by Air failure	
cm <sup>2</sup>	Code	mm	Code	bar	Code	nec. Air Supply ( bar )	max. Air Supply ( bar )	max. Force ( N )	max. Air Supply ( bar )	max. Force ( N )
250	253	13	L	0,5 - 1,4	BL	1,8	2,0	1 250	6,0	11 500
				1,0 - 1,9	DY	2,3	2,5	2 500	6,0	10 250
				1,5 - 2,3	VC	2,7	3,0	3 750	6,0	9 250
				1,5 - 3,0	VI	3,4	4,0	3 750	6,0	7 500
				2,0 - 3,8	FY	4,2	4,5	5 000	6,0	5 500
		19	G	0,2 - 1,0	AD	1,4	2,0	500	6,0	12 500
				0,5 - 1,8	BL	2,2	2,5	1 250	6,0	10 500
				1,0 - 2,3	DY	2,7	3,0	2 500	6,0	9 250
				1,5 - 2,6	VC	3,0	3,5	3 750	6,0	8 500
				1,5 - 3,7	VI	4,1	4,5	3 750	6,0	5 750
				2,0 - 4,7	FY	5,1	5,5	5 000	6,0	3 250
				0,2 - 1,0	AD	1,4	2,0	1 000	6,0	25 000
500	503	19	G	0,5 - 1,8	BL	2,2	2,5	2 500	6,0	21 000
				1,0 - 2,3	DY	2,7	3,0	5 000	6,0	18 500
				1,5 - 2,6	VC	3,0	3,5	7 500	6,0	17 000
				1,5 - 3,7	VI	4,1	4,5	7 500	6,0	11 500
				2,0 - 4,7	FY	5,1	5,5	10 000	6,0	6 500
				0,5 - 1,4	BL	1,8	2,0	2 500	6,0	23 000
		25	N	1,0 - 1,9	DY	2,3	2,5	5 000	6,0	20 500
				1,5 - 2,3	VC	2,7	3,0	7 500	6,0	18 500
				1,5 - 2,9	VI	3,3	3,5	7 500	6,0	15 500
				2,0 - 3,8	FY	4,2	4,5	10 000	6,0	11 000
				0,2 - 1,0	AD	1,4	2,0	1 000	6,0	25 000
		38	H	0,5 - 1,8	BL	2,2	2,5	2 500	6,0	21 000
				1,0 - 2,3	DY	2,7	3,0	5 000	6,0	18 500
				1,5 - 2,6	VC	3,0	3,5	7 500	6,0	17 000
				1,5 - 3,7	VI	4,1	4,5	7 500	6,0	11 500
				2,0 - 4,7	FY	5,1	5,5	10 000	6,0	6 500

**Attention:**

- 6**
- The max. air supply is designed to maintain a long operating life !
  - Max. design pressure for the actuators → 6 bar !
  - In order to achieve best performance, select a suitable spring range for required stiffness !
  - All data is rounded up to nearest number and should only be used as a best estimate !

Stem retracts by Air failure ( bar / N )										
1,6	1,8	2,0	2,2	2,5	2,8	3,2	3,6	4,0	4,5	5,0
500	1000	1 500	2 000	2 750	3 500	4 500	5 500	6 500	7 750	9 000
		250	750	1 500	2 250	3 250	4 250	5 250	6 500	7 750
1 500	2 000	2 500	3 000	3 750	4 500	5 500	6 500	7 500	8 750	10 000
		500	1 000	1 750	2 500	3 500	4 500	5 500	6 750	8 000
3 000	4 000	5 000	6 000	7 500	9 000	11 000	13 000	15 000	17 500	20 000
		1 000	2 000	3 500	5 000	7 000	9 000	11 000	13 500	16 000
1 000	2 000	3 000	4 000	5 500	7 000	9 000	11 000	13 000	15 500	18 000
		500	1 500	3 000	4 500	6 500	8 500	10 500	13 000	15 500
3 000	4 000	5 000	6 000	7 500	9 000	11 000	13 000	15 000	17 500	20 000
		1 000	2 000	3 500	5 000	7 000	9 000	11 000	13 500	16 000

## Positioning Force for Actuator Size - 700 ( DIN )

Effective Area		Stroke		Spring Range		Stem extends by Air failure			Stem retracts by Air failure	
cm <sup>2</sup>	Code	mm	Code	bar	Code	nec. Air Supply ( bar )	max. Air Supply ( bar )	max. Force ( N )	max. Air Supply ( bar )	max. Force ( N )
700	701	25	N	0,5 - 1,4	BL	1,8	2,0	3 500	6,0	32 200
				1,0 - 1,9	DY	2,3	2,5	7 000	6,0	28 700
				1,5 - 2,3	VC	2,7	3,0	10 500	6,0	25 900
				1,5 - 2,9	VI	3,3	3,5	10 500	6,0	21 700
				2,0 - 3,8	FY	4,2	4,5	14 000	6,0	15 400
		38	H	0,2 - 1,0	AD	1,4	2,0	1 400	6,0	35 000
				0,5 - 1,8	BL	2,2	2,5	3 500	6,0	29 400
				1,0 - 2,3	DY	2,7	3,0	7 000	6,0	25 900
				1,5 - 2,6	VC	3,0	3,5	10 500	6,0	23 800
				1,5 - 3,7	VI	4,1	4,5	10 500	6,0	16 100
				2,0 - 4,7	FY	5,1	5,5	14 000	6,0	9 100
		51	O	0,2 - 0,9	AD	1,3	1,5	1 400	6,0	35 700
				0,5 - 1,7	BL	2,1	2,5	3 500	6,0	30 100
				1,0 - 2,2	DY	2,6	3,0	7 000	6,0	26 600
				1,5 - 3,5	VI	3,9	4,5	10 500	6,0	17 500
2,0 - 4,4	FY			4,8	5,0	14 000	6,0	11 200		

### Attention:

- 8
- The max. air supply is designed to maintain a long operating life !
  - Max. design pressure for the actuators → 6 bar !
  - In order to achieve best performance, select a suitable spring range for required stiffness !
  - All data is rounded up to nearest number and should only be used as a best estimate !



Stem retracts by Air failure ( bar / N )										
1,6	1,8	2,0	2,2	2,5	2,8	3,2	3,6	4,0	4,5	5,0
1 400	2 800	4 200	5 600	7 700	9 800	12 600	15 400	18 200	21 700	25 200
		700	2 100	4 200	6 300	9 100	11 900	14 700	18 200	21 700
4 200	5 600	7 000	8 400	10 500	12 600	15 400	18 200	21 000	24 500	28 000
		1 400	2 800	4 900	7 000	9 800	12 600	15 400	18 900	22 400
4 900	6 300	7 700	9 100	11 200	13 300	16 100	18 900	21 700	25 200	28 700
	700	2 100	3 500	5 600	7 700	10 500	13 300	16 100	19 600	23 100

## Positioning Force for Actuator Size - 1500 ( DIN )

Effective Area		Stroke		Spring Range		Stem extends by Air failure			Stem retracts by Air failure	
cm <sup>2</sup>	Code	mm	Code	bar	Code	nec. Air Supply ( bar )	max. Air Supply ( bar )	max. Force ( N )	max. Air Supply ( bar )	max. Force ( N )
1500	1502	25	N	0,4 - 1,4	GF	1,8	2,0	6 000	5,4	60 000
				1,2 - 2,0	NZ	2,4	3,0	18 000	6,0	60 000
				1,5 - 2,3	VC	2,7	3,0	22 500	6,0	55 500
				2,0 - 2,9	FS	3,3	3,5	30 000	6,0	46 500
				2,6 - 3,6	AJ	4,0	4,5	39 000	6,0	36 000
		38	H	0,2 - 1,0	AD	1,4	2,0	3 000	5,0	60 000
				0,4 - 1,9	GF	2,3	2,5	6 000	5,9	60 000
				0,75 - 1,4	KI	1,8	2,0	11 250	5,4	60 000
				1,2 - 2,4	NZ	2,8	3,0	18 000	6,0	54 000
				1,5 - 2,6	VC	3,0	3,5	22 500	6,0	51 000
				2,0 - 3,4	FS	3,8	4,0	30 000	6,0	39 000
				2,6 - 4,1	AJ	4,5	5,0	39 000	6,0	28 500
		51	O	0,2 - 0,9	AD	1,3	1,5	3 000	4,9	60 000
				0,4 - 1,8	GF	2,2	2,5	6 000	5,8	60 000
				1,5 - 2,5	VC	2,9	3,5	22 500	6,0	52 500
				1,9 - 3,0	LM	3,4	4,0	28 500	5,8	42 000
				2,0 - 3,3	FS	3,7	4,0	30 000	6,0	40 500
				2,6 - 4,0	AJ	4,4	5,0	39 000	6,0	30 000
		64	P	0,2 - 0,8	AD	1,2	1,5	3 000	4,8	60 000
				0,4 - 1,7	GF	2,1	2,5	6 000	5,7	60 000
				1,5 - 2,5	VC	2,9	3,5	22 500	6,0	52 500
				2,0 - 3,2	FS	3,6	4,0	30 000	6,0	42 000
				2,6 - 3,9	AJ	4,3	4,5	39 000	6,0	31 500
		76	I	0,2 - 1,0	AD	1,4	2,0	3 000	5,0	60 000
				0,4 - 1,9	GF	2,3	2,5	6 000	5,9	60 000
				0,8 - 1,4	KI	1,8	2,0	11 250	5,4	60 000
				1,5 - 2,6	VC	3,0	3,5	22 500	6,0	51 000
				2,0 - 3,4	FS	3,8	4,0	30 000	6,0	39 000
				2,6 - 4,1	AJ	4,5	5,0	39 000	6,0	28 500

**Attention:**
**10**

- The max. air supply is designed to maintain a long operating life !
- Max. design pressure for the actuators → 6 bar !
- In order to achieve best performance, select a suitable spring range for required stiffness !
- All data is rounded up to nearest number and should only be used as a best estimate !

Stem retracts by Air failure ( bar / N )										
1,6	1,8	2,0	2,2	2,5	2,8	3,2	3,6	4,0	4,5	5,0
3 000	6 000	9 000	12 000	16 500	21 000	27 000	33 000	39 000	46 500	54 000
			3 000	7 500	12 000	18 000	24 000	30 000	37 500	45 000
9 000	12 000	15 000	18 000	22 500	27 000	33 000	39 000	45 000	52 500	60 000
		1 500	4 500	9 000	13 500	19 500	25 500	31 500	39 000	46 500
10 500	13 500	16 500	19 500	24 000	28 500	34 500	40 500	46 500	54 000	
		3 000	6 000	10 500	15 000	21 000	27 000	33 000	40 500	48 000
12 000	15 000	18 000	21 000	25 500	30 000	36 000	42 000	48 000	55 500	
	1 500	4 500	7 500	12 000	16 500	22 500	28 500	34 500	42 000	49 500
9 000	12 000	15 000	18 000	22 500	27 000	33 000	39 000	45 000	52 500	60 000
		1 500	4 500	9 000	13 500	19 500	25 500	31 500	39 000	46 500

# Dimensions - DIN-Units

IAS - Yoke design, Type IM

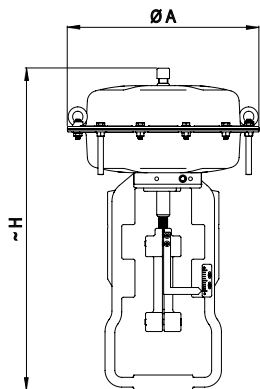

Standard actuator

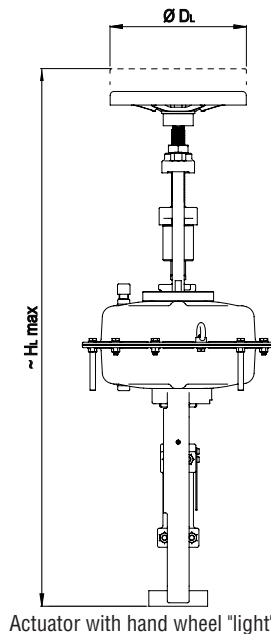
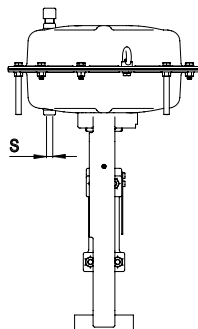

Actuator with hand wheel "light"

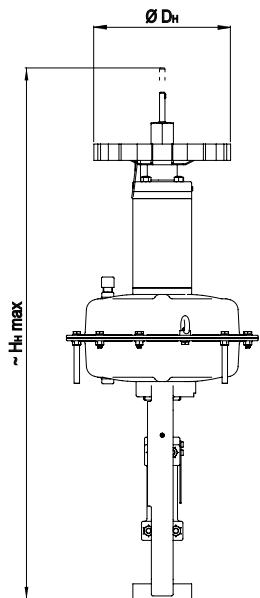

Actuator with hand wheel "heavy"

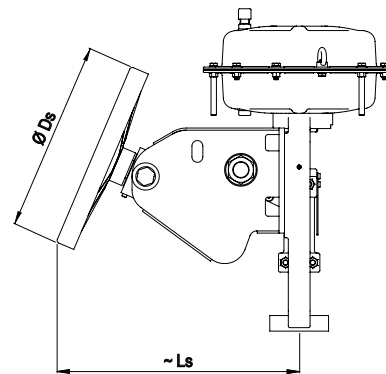

Actuator with hand wheel "side"

Designation	Actuator Size	250		500			700		
		Stroke mm		13	19	25	38	25	38
Ø A	mm	260		355			390		
~ H	mm	360		630			640		
S = air connection	in.	G 1/4							
Ø DL	mm	200		300			-		
~ HL max	mm	600	1 050	1 055	1 060	-			
Ø DH	mm	200		250			350		
~ HH max	mm	585	1 040	1 045	1 050	1 110	1 115	1 120	
Ø Ds	mm	200		500					
~ Ls	mm	210		660					
~ Weight	kg	13	45			45		48	
~ Weight with hand wheel "light"	kg	17	53			-		-	
~ Weight with hand wheel "heavy"	kg	20	53			67		70	
~ Weight with hand wheel "side"	kg	17	75			75		78	

## Dimensions - DIN-Units

NAMUR - Yoke design, Type PM

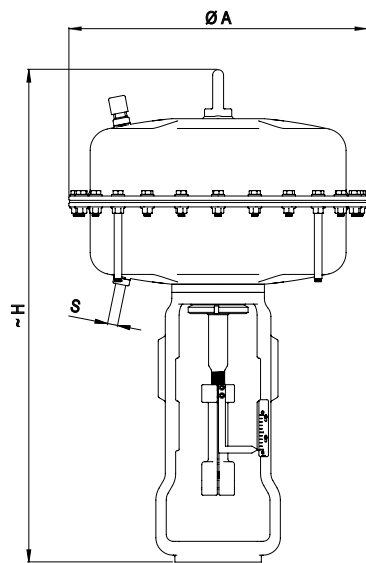

Standard NAMUR yoke actuator - Type PB

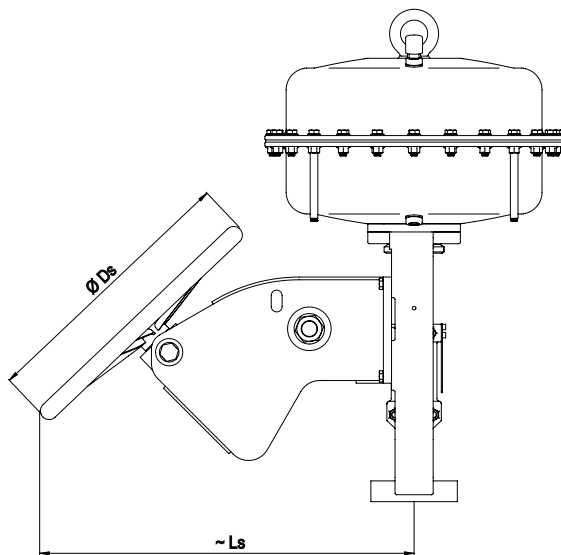

PB - Actuator with hand wheel "side"

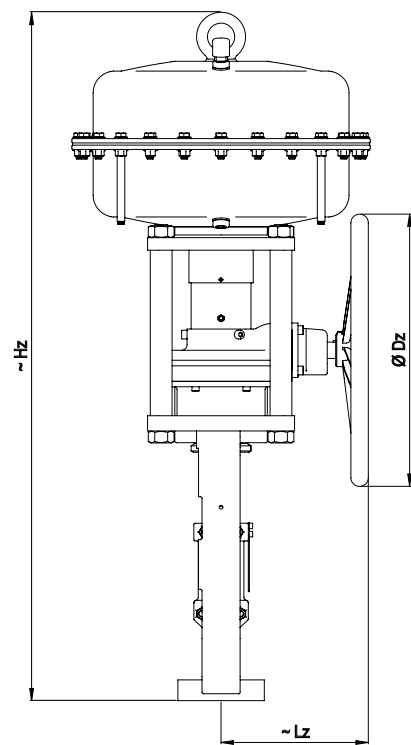

PB - Actuator with hand wheel "centric"

Designation	Actuator Size	1500				
		Stroke mm	25	38	51	64
Ø A	mm	548				
~ H	mm	915				
S = air connection	in.	G 1/2				
Ø Ds	mm	500				
~ Ls	mm	685				
~ Hz	mm	1 275				
Ø Dz	mm	500				
~ Lz	mm	270				
~ Weight	kg		124			126
~ Weight with hand wheel "side"	kg		171			173
~ Weight with hand wheel "centric"	kg		209			211

# Yoke - connection dimensions

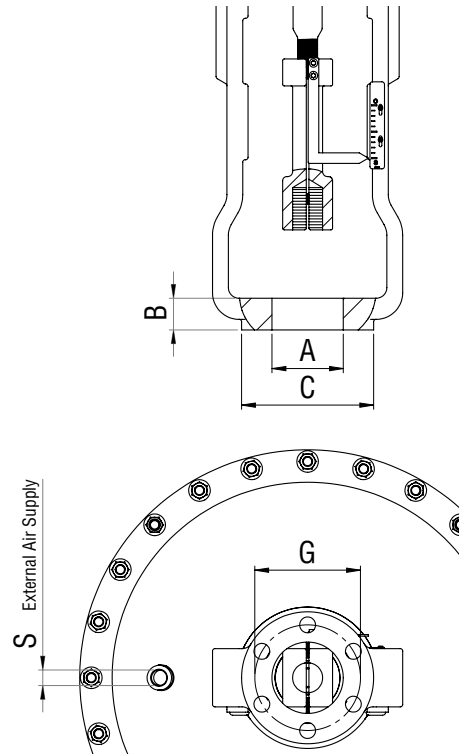
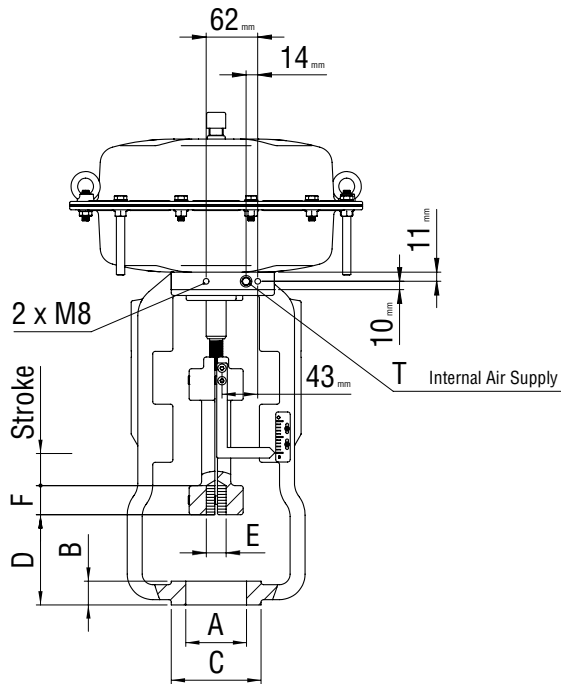

Interface for MarkOne-*IAS*-yoke

Actuator Size	Stroke	Spud Size	Stem			Mounting Bolts			Spud Thickness	Boss Diameter	Internal Air Supply	External Air Supply					
			Extend	Thread	Thread depth	Bolt Circle	Size	Quantity									
		A	D	E	F	G			B	C	T	S					
253	0.50	2.00	2.94	0.50-20	0.75	N/R			0.69	2.62	G 3/8 (Plug according to DIN 908 & O-ring 10 x 2 mm - if applicable)	G 1/4 (Plug according to DIN 906 - if applicable)					
	0.75			0.75-16	1.02				1.06	4.25							
503	0.75	2.62	3.56	1.00-12	1.25				0.69	4.25							
		2.00	2.94	0.75-16	1.02				1.06	4.25							
	1.00	2.62	3.56	1.00-12	1.25				1.06	4.25							
		2.00	2.94	0.75-16	1.02												
1.50	2.62	3.56	1.00-12	1.25	1.06				4.25								
	2.00	2.94	0.75-16	1.02													
701	1.00	2.62	3.56	0.75-16	1.02				5.00	0.625-11			6	1.06	4.25	G 3/8 (Plug according to DIN 908 & O-ring 10 x 2 mm - if applicable)	G 1/4 (Plug according to DIN 906 - if applicable)
		2.88	4.28	1.00-12	1.25									1.13			
	1.50	2.62	3.56	0.75-16	1.02									1.06			
		2.88	4.28	1.00-12	1.25									1.13			
	2.00	2.62	3.56	0.75-16	1.02	1.06											
				1.00-12	1.25	1.13											
		2.88	4.28	1.00-12	1.25	1.13											
				1.50-12	1.88	1.50	6.25										
	2.00-12	2.38	1.50	6.25													
	1502	1.00	2.88	4.28	1.00-12	1.25	5.00	0.625-11			6	1.13		4.25			
1.50		1.50							6.25								
2.00		2.88	4.88	1.50-12	1.88	1.13			4.25								
		3.38								2.00-12		2.38	1.50	6.25			
2.50		2.88	4.28	1.00-12	1.25	1.13			4.25								
		3.38		1.50-12	1.88					1.50		6.25					
3.00		2.88	4.28	1.00-12	1.25	1.13			4.25								
				3.38	1.50-12					1.88		1.50	6.25				
				2.00-12	2.38	1.50			6.25								

## Minimum Clearance Zone

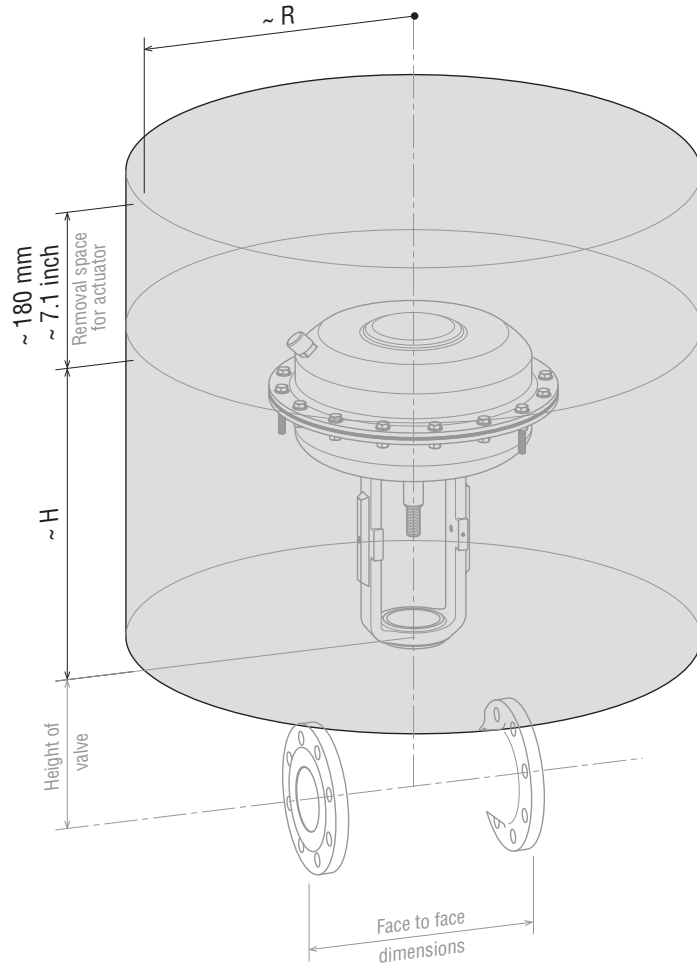

Actuator Size	$\sim R$				$\sim H_{\text{max}}$	
	without accessories	accessories direct mounted	accessories NAMUR - mounted	with side mounted hand wheel	without hand wheel	with top mounted hand wheel
253	135	195	290	210	360	610
503	180	195	330	665	630	1020
701	205	205	345	665	635	1100
1502	275	-	415	685	915	-

## Positioning Force for Actuator Size - 250 to 500 ( ASME )

Effective Area		Stroke		Spring range		Stem extends by Air failure			Stem retracts by Air failure	
inch <sup>2</sup>	Code	inch	Code	psig	Code	nec. Air Supply (psig)	max. Air Supply (psig)	max. Force (lbs)	max. Air Supply (psig)	max. Force (lbs)
38.8	253	0.50	L	7 - 20	BL	26	29	281	87	2 585
				15 - 28	DY	33	36	562	87	2 304
				22 - 33	VC	39	44	843	87	2 079
				22 - 44	VI	49	58	843	87	1 686
				29 - 55	FY	61	65	1 124	87	1 236
		0.75	G	3 - 15	AD	20	29	112	87	2 810
				7 - 26	BL	32	36	281	87	2 360
				15 - 33	DY	39	44	562	87	2 079
				22 - 38	VC	44	51	843	87	1 911
				22 - 54	VI	59	65	843	87	1 293
				29 - 68	FY	74	80	1 124	87	731
				3 - 15	AD	20	29	225	87	5 620
77.5	503	0.75	G	7 - 26	BL	32	36	562	87	4 721
				15 - 33	DY	39	44	1 124	87	4 159
				22 - 38	VC	44	51	1 686	87	3 822
				22 - 54	VI	59	65	1 686	87	2 585
				29 - 68	FY	74	80	2 248	87	1 461
				7 - 20	BL	26	29	562	87	5 171
		1.00	N	15 - 28	DY	33	36	1 124	87	4 609
				22 - 33	VC	39	44	1 686	87	4 159
				22 - 42	VI	48	51	1 686	87	3 485
				29 - 55	FY	61	65	2 248	87	2 473
				3 - 15	AD	20	29	225	87	5 620
				7 - 26	BL	32	36	562	87	4 721
		1.50	H	15 - 33	DY	39	44	1 124	87	4 159
				22 - 38	VC	44	51	1 686	87	3 822
				22 - 54	VI	59	65	1 686	87	2 585
				29 - 68	FY	74	80	2 248	87	1 461
				3 - 15	AD	20	29	225	87	5 620
				7 - 26	BL	32	36	562	87	4 721

**Attention:**
**16**

- The max. air supply is designed to maintain a long operating life !
- Max. design pressure for the actuators → 87 psi !
- In order to achieve best performance, select a suitable spring range for required stiffness !
- All data is rounded up to nearest number and should only be used as a best estimate !



Stem retracts by Air failure ( bar / N )										
1,6	1,8	2,0	2,2	2,5	2,8	3,2	3,6	4,0	4,5	5,0
112	225	337	450	618	787	1 012	1 236	1 461	1 742	2 023
		56	169	337	506	731	955	1 180	1 461	1 742
337	450	562	674	843	1 012	1 236	1 461	1 686	1 967	2 248
		112	225	393	562	787	1 012	1 236	1 517	1 798
674	899	1 124	1 349	1 686	2 023	2 473	2 923	3 372	3 934	4 496
		225	450	787	1 124	1 574	2 023	2 473	3 035	3 597
225	450	674	899	1 236	1 574	2 023	2 473	2 923	3 485	4 047
		112	337	674	1 012	1 461	1 911	2 360	2 923	3 485
674	899	1 124	1 349	1 686	2 023	2 473	2 923	3 372	3 934	4 496
		225	450	787	1 124	1 574	2 023	2 473	3 035	3 597

## Positioning Force for Actuator Size - 700 ( ASME )

Effective Area		Stroke		Spring range		Stem extends by Air failure			Stem retracts by Air failure	
inch <sup>2</sup>	Code	inch	Code	psig	Code	nec. Air Supply (psig)	max. Air Supply (psig)	max. Force (lbs)	max. Air Supply (psig)	max. Force (lbs)
109	701	1.00	N	7 - 20	BL	26	29	787	87	7 239
				15 - 28	DY	33	36	1 574	87	6 452
				22 - 33	VC	39	44	2 360	87	5 823
				22 - 42	VI	48	51	2 360	87	4 878
				29 - 55	FY	61	65	3 147	87	3 462
		1.50	H	3 - 15	AD	20	29	315	87	7 868
				7 - 26	BL	32	36	787	87	6 609
				15 - 33	DY	39	44	1 574	87	5 823
				22 - 38	VC	44	51	2 360	87	5 350
				22 - 54	VI	59	65	2 360	87	3 619
				29 - 68	FY	74	80	3 147	87	2 046
		2.00	O	3 - 13	AD	19	22	315	87	8 026
				7 - 25	BL	30	36	787	87	6 767
				15 - 32	DY	38	44	1 574	87	5 980
				22 - 51	VI	57	65	2 360	87	3 934
				29 - 64	FY	70	73	3 147	87	2 518

**Attention:**

- The max. air supply is designed to maintain a long operating life !
- Max. design pressure for the actuators → 87 psi !
- In order to achieve best performance, select a suitable spring range for required stiffness !
- All data is rounded up to nearest number and should only be used as a best estimate !

Stem retracts by Air failure ( psig / lbs )										
23	26	29	32	36	41	46	52	58	65	73
315	629	944	1 259	1 731	2 203	2 833	3 462	4 092	4 878	5 665
		157	472	944	1 416	2 046	2 675	3 305	4 092	4 878
944	1 259	1 574	1 888	2 360	2 833	3 462	4 092	4 712	5 508	6 295
		315	629	1 102	1 574	2 203	2 833	3 462	4 249	5 036
1 102	1 416	1 731	2 046	2 518	2 990	3 619	4 249	4 878	5 665	6 452
		472	787	1 259	1 731	2 360	2 990	3 619	4 406	5 193

## Positioning Force for Actuator Size - 1500 ( ASME )

Effective Area		Stroke		Spring range		Stem extends by Air failure			Stem retracts by Air failure			
inch <sup>2</sup>	Code	inch	Code	psig	Code	nec. Air Supply (psig)	max. Air Supply (psig)	max. Force (lbs)	max. Air Supply (psig)	max. Force (lbs)		
233	1502	1.00	N	6 - 20	GF	26	29	1 349	78	13 489		
				17 - 29	NZ	35	44	4 047	87	13 489		
				22 - 33	VC	39	44	5 058	87	12 477		
				29 - 42	FS	48	51	6 744	87	10 454		
				38 - 52	AJ	58	65	8 768	87	8 093		
		1.50	H	3 - 15	AD	20	29	674	73	13 489	73	13 489
				6 - 28	GF	33	36	1 349	86	13 489	86	13 489
				11 - 20	KI	26	29	2 529	78	13 489	78	13 489
				17 - 35	NZ	41	44	4 047	87	12 140	87	12 140
				22 - 38	VC	44	51	5 058	87	11 465	87	11 465
				29 - 49	FS	55	58	6 744	87	8 768	87	8 768
		2.00	O	38 - 59	AJ	65	73	8 768	87	6 407	87	6 407
				3 - 13	AD	19	22	674	71	13 489	71	13 489
				6 - 26	GF	32	36	1 349	84	13 489	84	13 489
				22 - 36	VC	42	51	5 058	87	11 802	87	11 802
				28 - 44	LM	49	58	6 407	87	10 116	87	10 116
				29 - 48	FS	54	58	6 744	87	9 105	87	9 105
		2.50	P	38 - 58	AJ	64	73	8 768	87	6 744	87	6 744
				3 - 12	AD	17	22	674	70	13 489	70	13 489
				6 - 25	GF	30	36	1 349	83	13 489	83	13 489
				22 - 36	VC	42	51	5 058	87	11 802	87	11 802
				29 - 46	FS	52	58	6 744	87	9 442	87	9 442
		3.00	I	38 - 57	AJ	62	65	8 768	87	7 081	87	7 081
				3 - 15	AD	20	29	674	73	13 489	73	13 489
6 - 28	GF			33	36	1 349	86	13 489	86	13 489		
11 - 20	KI			26	29	2 529	78	13 489	78	13 489		
22 - 38	VC			44	51	5 058	87	11 465	87	11 465		
29 - 49	FS			55	58	6 744	87	8 768	87	8 768		
				38 - 59	AJ	65	73	8 768	87	6 407		

**Attention:**

- The max. air supply is designed to maintain a long operating life !
- Max. design pressure for the actuators → 87 psi !
- In order to achieve best performance, select a suitable spring range for required stiffness !
- All data is rounded up to nearest number and should only be used as a best estimate !

Stem retracts by Air failure ( psig / lbs )										
23	26	29	32	36	41	46	52	58	65	73
674	1 349	2 023	2 698	3 709	4 721	6 070	7 419	8 768	10 454	12 140
			674	1 686	2 698	4 047	5 395	6 744	8 430	10 116
2 023	2 698	3 372	4 047	5 058	6 070	7 419	8 768	10 116	11 802	13 489
		337	1 012	2 023	3 035	4 384	5 733	7 081	8 768	10 454
2 360	3 035	3 709	4 384	5 395	6 407	7 756	9 105	10 454	12 140	13 826
		674	1 349	2 360	3 372	4 721	6 070	7 419	9 105	10 791
2 698	3 372	4 047	4 721	5 733	6 744	8 093	9 442	10 791	12 477	14 163
	337	1 012	1 686	2 698	3 709	5 058	6 407	7 756	9 442	11 128
2 023	2 698	3 372	4 047	5 058	6 070	7 419	8 768	10 116	11 802	13 489
		337	1 012	2 023	3 035	4 384	5 733	7 081	8 768	10 454

## Dimensions - ASME-Units

IAS - Yoke design, Type IM

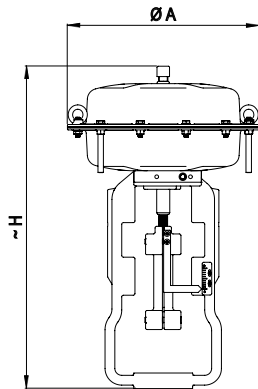

Standard actuator

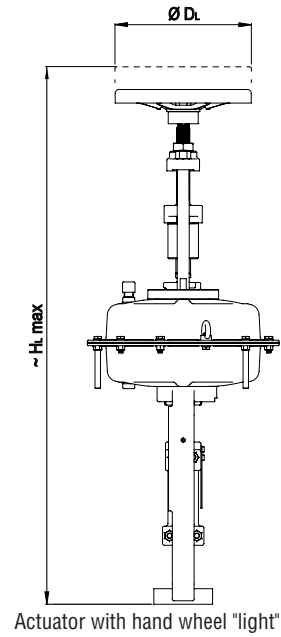
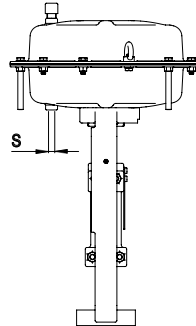

Actuator with hand wheel "light"

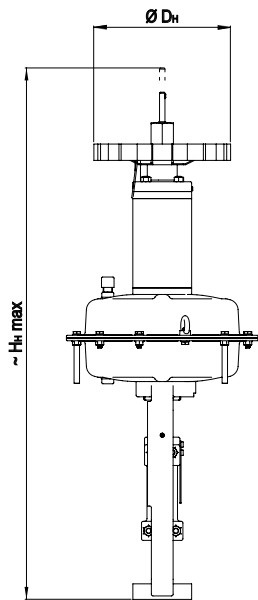

Actuator with hand wheel "heavy"

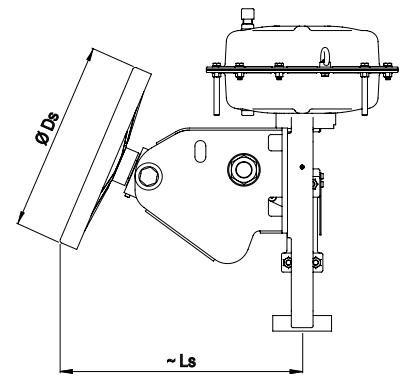

Actuator with hand wheel "side"

Designation	Actuator Size	250		500			700			
		Stroke inch	0.50	0.75	1.00	1.50	1.00	1.50	2.00	
Ø A	inch	10.2		14.0			15.4			
~ H	inch	14.2		24.8			25.2			
S = air connection	inch	G 1/4								
Ø DL	inch	7.9		11.8			-			
~ HL max	inch	23.6	41.3	41.5	41.7	-				
Ø DH	inch	7.9		9.9			13.8			
~ HH max	inch	23.0	40.9	41.1	41.3	43.7	43.9	44.1		
Ø Ds	inch	7.9	19.7							
~ Ls	inch	8.3	26.0							
~ Weight	lbs	29	100			100		106		
~ Weight with hand wheel "light"	lbs	38	117			-				
~ Weight with hand wheel "heavy"	lbs	44	117			148		154		
~ Weight with hand wheel "side"	lbs	38	166			165		172		

# Dimensions - ASME-Units

NAMUR - Yoke design, Type PM

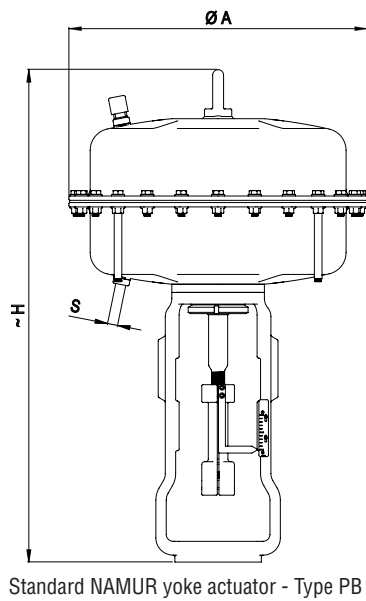

Standard NAMUR yoke actuator - Type PB

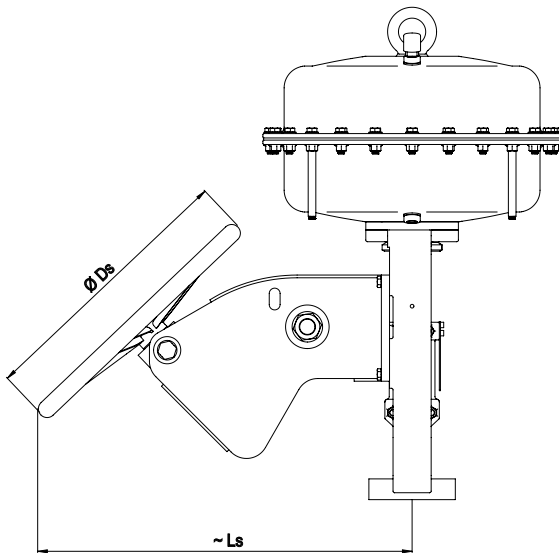

PB - Actuator with hand wheel "side"

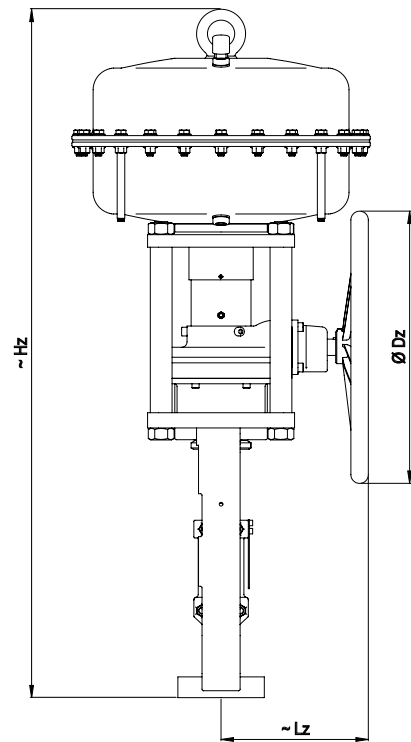

PB - Actuator with hand wheel "centric"

Designation	Actuator Size	1500				
		Stroke inch	1.00	1.50	2.00	2.50
Ø A	inch	21.6				
~ H	inch	36.0				
S = air connection	inch	G 1/2				
Ø Ds	inch	19.7				
~ Ls	inch	27.0				
~ Hz	inch	50.2				
Ø Dz	inch	19.7				
~ Lz	inch	10.6				
~ Weight	lbs	273			278	
~ Weight with hand wheel "side"	lbs	377			381	
~ Weight with hand wheel "centric"	lbs	461			465	

## Dimensions - Adjustable Stroke Limitation

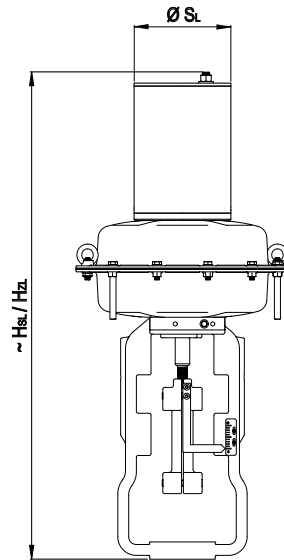

Designation		Actuator Size				
		250	500	700	1500	
DIN-Units	Ø SL	mm	108	160	160	180
	~ HSL	mm	480	840	850	1 205
	~ HZL	mm	-	-	-	1 565
	~ Weight without hand wheel	kg	17	58	61	153
	~ Weight with hand wheel "side"	kg	22	88	91	198
	~ Weight with hand wheel "centric"	kg	-	-	-	238
	ASME-Units	Ø SL	inch	4.3	6.3	6.3
~ HSL		inch	18.9	33.1	33.5	47.5
~ HZL		inch	-	-	-	61.6
~ Weight without hand wheel		lbs	37	128	135	337
~ Weight with hand wheel "side"		lbs	49	194	201	437
~ Weight with hand wheel "centric"		lbs	-	-	-	525



## Allowable installation position of the FlowAct

Actuator Size	Bonnet Type	Installation Position with deviation from the perpendicular						upright only
		without support 0 - 30 ° angle		without support 0 - 90 ° angle <sup>1)</sup>		with support 0 - 90 ° angle <sup>1)</sup>		
		without	with	without	with	without	with	
		Handwheel		Handwheel		Handwheel		
250	Standard	•	•	•	•			
	Extended	•	•	•	•			
	Bellows Seal	•	•	•	•			
	Cryogenic	•	•			•	•	
500	Standard	•	•	•	•			
	Extended	•	•	•	•			
	Bellows Seal	•	•	•			•	
	Cryogenic	•				•	•	
700	Standard	•	•	•			•	
	Extended	•	•	•			•	
	Bellows Seal	•	•			•	•	
	Cryogenic							•
1500	Standard	•	•			•	•	
	Extended	•	•			•	•	
	Bellows Seal	•					•	
	Cryogenic							•

<sup>1)</sup> ATTENTION: Strong yoke center line has to be mounted in a vertically direction !  
 Check the accurate installation position of the accessory !  
 The support should be designed to relieve the weight of the actuator and should not be rigid or anchor it !



# Pneumatic multi spring actuator - FlowAct order code

FlowAct		Order code										
		I	M	503	B	BL	O	Z	H	S		
Actuator design	Internal Air Supply for Yoke Code M	I										
	External Air Supply for Yoke Code M	P										
Yoke design	Without yoke		O									
	IAS - yoke for Valve-Series Mark One (253, 503, 701)											
	NAMUR - yoke for Valve-Series Mark One (1502)		M									
Actuator size (cm <sup>2</sup> /inch <sup>2</sup> )	250      38.75      Stroke      13, 19      0.50, 0.75      253											
	500      77.50      (mm/inch)      19, 25, 38      0.75, 1.00, 1.50      503											
	700      108.50      25, 38, 51      1.00, 1.50, 2.00      701											
	1500      232.50      25, 38, 51, 64, 76      1.00, 1.50, 2.00, 2.50, 3.00      1502											
Color	white, powder coated									B		
	blue, powder coated									A		
	yellow, powder coated									C		
Spring range (bar/psi)	Size / Stroke	253	253, 503	503, 701	701	1502						
	STD Range	0.50	0.75	1.00	1.50	2.00	1.00	1.50	2.00	2.50	3.00	
	0,2 - 1,0		3 - 15		3 - 15	3 - 13		3 - 15	3 - 13	3 - 12	3 - 15	AD
	0,4 - 2,0						6 - 20	6 - 28	6 - 26	6 - 25	6 - 28	GF
	0,5 - 1,9	7 - 20	7 - 26	7 - 20	7 - 26	7 - 25						BL
	0,75 - 1,4							11 - 20			11 - 20	KI
	1,0 - 2,4	15 - 28	15 - 33	15 - 28	15 - 33	15 - 32						DY
	1,2 - 2,5						17 - 29	17 - 35				NZ
	1,5 - 2,7	22 - 33	22 - 38	22 - 33	22 - 38		22 - 33	22 - 38	22 - 36	22 - 36	22 - 38	VC
	1,5 - 3,8	22 - 44	22 - 54	22 - 42	22 - 54	22 - 51						VI
	1,9 - 3,2								28 - 44			LM
	2,0 - 3,5						29 - 42	29 - 49	29 - 48	29 - 46	29 - 49	FS
	2,0 - 4,8	29 - 55	29 - 68	29 - 55	29 - 68	29 - 64						FY
2,6 - 4,2						38 - 52	38 - 59	38 - 58	38 - 57	38 - 59	AJ	
Handwheel	without										O	
	top mounted "light design"										L	
	top mounted "heavy design"										H	
	side mounted "light design"										S	
	central mounted "heavy design"										Z	
Stroke Limitation	not adjustable - "bottom"										E	
	not adjustable - "top"										F	
	"adjustable"										U	
Handwheel and Stroke Limitation	side mounted "light design" HW and "adjustable" SL for IM type only										A	
	central mounted "heavy design" HW and "adjustable" SL for 1502										D	
Safety position at air failure	spring to close										Z	
	spring to open										A	
	fail in place by spring to close										S	
	fail in place by spring to open										T	
Stroke (mm/inch)	13      0.50										L	
	19      0.75										G	
	25      1.00										N	
	38      1.50										H	
	51      2.00										O	
	64      2.50										P	
	76      3.00										I	
Temperature Range	Standard      - 40 °C to + 80 °C      - 40 °F to + 176 °F										S	
	Low      - 60 °C to + 80 °C      - 76 °F to + 176 °F										L	

**Attention:**

- The selection of the appropriate yoke is only possible in accordance with the Mark One valve (see page 14 - spud size, stem thread, etc.).



Valtek Flowtop FCD VLENTB0400-01 03/17 Printed in Europe.

**To find your local Flowserve representative**

or for more information about Flowserve Corporation,  
visit [www.flowserve.com](http://www.flowserve.com) or call USA 1 800 225 6989

Flowserve Corporation has established industry leadership in the design and manufacture of its products. When properly selected, this Flowserve product is designed to perform its intended function safely during its useful life. However, the purchaser or user of Flowserve products should be aware that Flowserve products might be used in numerous applications under a wide variety of industrial service conditions. Although Flowserve can (and often does) provide general guidelines, it cannot provide specific data and warnings for all possible applications. The purchaser/user must therefore assume the ultimate responsibility for the proper sizing and selection, installation, operation, and maintenance of Flowserve products. The purchaser/user should read and understand the Installation Operation Maintenance (IOM) instructions included with the product, and train its employees and contractors in the safe use of Flowserve products in connection with the specific application.

While the information and specifications contained in this literature are believed to be accurate, they are supplied for informative purposes only and should not be considered certified or as a guarantee of satisfactory results by reliance thereon. Nothing contained herein is to be construed as a warranty or guarantee, express or implied, regarding any matter with respect to this product. Because Flowserve is continually improving and upgrading its product design, the specifications, dimensions and information contained herein are subject to change without notice. Should any question arise concerning these provisions, the purchaser/user should contact Flowserve Corporation at any one of its worldwide operations or offices.

© 2017 Flowserve Control Valves GmbH, Villach, Austria, Europe. Flowserve is a registered trademark of Flowserve Corporation.

**USA**

Flowserve Flow Control Division  
1350 N. Mt. Springs Parkway  
Springville, UT 84663

USA

Phone: +1 801 489 8611

Fax: +1 801 489 3719

**Austria**

Flowserve Control Valves GmbH  
Kasernengasse 6  
9500 Villach

AUSTRIA

Phone: +43 (0) 424241181 - 0

Fax: +43 (0) 424241181 - 50

**India**

Flowserve India Controls Pvt Ltd.  
Plot # 4, 1A, Road #8 EPIP  
Whitefield Bangalore, Karnataka,  
560066

INDIA

Phone: 918040146200

Fax: 918028410286

**China**

Flowserve Fluid Motion and  
Control (Suzhou) Co., Ltd.

No. 35, Baiyu Road,  
Suzhou Industrial Park, Shzhou  
Jiangsu Province, P.R. 215021

CHINA

Phone: 86 512 6288 8790

Fax: 86 512 6288 8736

**Singapore**

Flowserve Pte. Ltd.

12 Tuas Avenue 20  
Republic of Singapore 638824  
Singapore

Phone: +65 6879 8900

Fax: +65 6862 4940

**Saudi Arabia**

Flowserve Abahsain Flow Control  
Co.,  
Ltd.

Makkah Road, Phase 4  
Plot 10 & 12, 2nd Industrial City  
Dammam, Kingdom of Saudi  
Arabia

Phone: +966 3 857 3150 X 243

Fax: +966 3 857 4243