



USER INSTRUCTIONS

Spring Diaphragm Rotary Actuators

FCD VLAIM050-01 – 05/12





*Installation
Operation
Maintenance*

Contents

Terms Concerning Safety	3
General Information	3
Unpacking	4
Installation	4
Changing Air Action	4
Sectional View of Spring Diaphragm Rotary Actuator	6
Replacing the Diaphragm, Without Removing the Diaphragm Box	7
Replacing the Spring or Diaphragm	8
Exploded View of Spring Diaphragm Rotary Actuator	9
Mounting Orientations	10
Spring Diaphragm Rotary Actuator	10
Troubleshooting Rotary Actuators	11

Terms Concerning Safety

The safety terms DANGER, WARNING, CAUTION and NOTE are used in these instructions to highlight particular dangers and/or to provide additional information on aspects that may not be readily apparent.

-  **DANGER:** indicates that death, severe personal injury and/or substantial property damage will occur if proper precautions are not taken.
-  **WARNING:** indicates that death, severe personal injury and/or substantial property damage can occur if proper precautions are not taken.
-  **CAUTION:** indicates that minor personal injury and/or property damage can occur if proper precautions are not taken.
-  **NOTE:** indicates and provides additional technical information, which may not be very obvious even to qualified personnel. Compliance with other, not particularly emphasized notes, with regard to transport, assembly, operation and maintenance and with regard to technical documentation (e.g. in the operating instruction, product documentation or on the product itself) is essential, in order to avoid faults, which in themselves might directly or indirectly cause severe personal injury or property damage.

General Information

The following instructions are designed to assist in unpacking, installing and performing maintenance as required on Flowserve Spring Diaphragm Rotary Actuators. Product users and maintenance personnel should thoroughly review this bulletin prior to installing, operating or performing any maintenance on the actuator. Separate maintenance instructions cover additional components, such as Valdisk and ShearStream body components, MaxFlo 3, Valdisk and ShearStream body assemblies, fail-safe systems, limit switches, handlevers, position transmitters and handwheels.

This publication does not contain information on Flowserve positioners. Refer to the appropriate maintenance bulletin for installing, calibrating, maintaining, troubleshooting and operating Flowserve positioners.

To avoid possible injury to personnel or damage to valve parts, WARNING and CAUTION notes must be strictly followed. Modifying this product, substituting non-factory parts or using maintenance procedures other than outlined could drastically affect performance and be hazardous to personnel and equipment.

Unpacking

1. While unpacking the actuator, check the packing list against the materials received.
 2. When lifting the actuator from the shipping container, position lifting straps and hoist to avoid damage to tubing and mounted accessories.
- ⚠ WARNING: When lifting an actuator with lifting straps, be aware the center of gravity may be above the lifting point. Therefore, support must be given to prevent the actuator from rotating. Failure to do so can cause serious injury to personnel and damage to actuator or nearby equipment.**
3. Contact your shipper immediately for any shipping damage.
 4. Contact your Flowserve representative for any problems.

Installation

Notice that the NR actuator has (4) rubber plugs (436) in the diaphragm box (202). These rubber plugs (436) function as a drain. After the valve is installed, remove one of the 4 plugs (436) that will allow any moisture that develops in the diaphragm box to drain out. Leave the other 3 plugs in place.

Changing Air Action

⚠ Follow all steps carefully, actuator spring is under compression

1. Position valve vertically
 - It is easier to change the air action with the valve in this position.
 2. Remove cover plates and positioner
 - Remove the (4) bolts (337) in the cover plate and remove the cover plate (363). Remove the (4) bolts (337) in the positioner cover plate and remove the positioner cover plate.

! NOTE: It is easier to leave the positioner mounted to the cover plate.
 3. Remove hand wheel (See Kit #397 Handwheel Assembly) and Limit stop (See Kit #330 Limit Stop Sub-Assembly)
 - If a hand wheel is used it will have to be removed along with the limit stop.
- 4**
- If no hand wheel is used this step can be skipped. You will need to loosen the limit stops and back them out a few turns, but they do not need to be removed.
 - There are two set screws (5) that hold the hand wheel nut (7) in place, loosen these and remove the hand wheel nut (7).

- Remove the hand wheel drive shaft from the transfer case.
 - Remove Limit stop (See Kit #330 Limit Stop Sub-Assembly).
4. Position the valve at mid stroke and remove the clevis pin snap ring (250)
 - By using a regulated air supply, the spring in the diaphragm box is compressed. Position the valve at mid stroke to relieve spring compression.
 - Remove the lower snap ring (250)
 - The clevis pin (361) should slide freely up and down, for size NR1 & NR2 actuators. It will be tight for size NR3.
 5. Remove the clevis pin (361)
 - Keep the valve positioned at mid stroke to relieve spring compression.
 - Remove the clevis pin (361), it should slide freely for actuator sizes NR1 & NR2.

! NOTE: For size NR3 actuators, the clevis pin (361) will be tight and might require a punch to drive it out.
 6. Separate the clevis (364) and the lever (See Kit #249 Lever Sub-Assembly)
 - Turn the Air supply pressure to 0, or remove the air supply.
 - The clevis (364) and the lever will slide apart easily now as you relieve air pressure.
 7. Remove the diaphragm box nuts (369)
 - Remove the diaphragm box nuts from the transfer case.
 8. Remove the diaphragm box assembly (202)
 9. Remove the diaphragm box plugs (407 & 406)
 - Remove the black square rubber plug (407) and the 2 small round rubber plugs (406) install them in the opposite side of the transfer case.
 - The purpose of these plugs is to seal the transfer case. This is the unused flange for the diaphragm box.
 10. Loosen the clevis nut (365) on the clevis (364)
 - Loosen the clevis nut (365) between the actuator stem (211) and the clevis (364).
 - This has to be loosened so it can swivel and fit in the transfer case correctly with the new air action.
 11. Install the diaphragm box assembly (202) on the opposite side
 - Install the diaphragm box assembly on the opposite side of the transfer case.

12. Install Diaphragm box nuts (369)
 - Tighten the diaphragm box nuts to the transfer case.
13. Line up the lever (See Kit #249 Lever Sub-Assembly) and clevis (364)
 - The lever and clevis will not line up. You have to apply air pressure to line them up.
 - This offset is caused by the spring pre-load.
14. Install the clevis pin (361)
 - Install the clevis pin (361).
 - Using a regulator, measure the air pressure required to stroke the valve 100% open. (Using stroke indicator)
 - Measure the air pressure to position the valve at 0% or closed into the seat (metal seat). 5% open if a soft seat is used.
 - By screwing the clevis (364) “into” or “out of” the actuator stem (211), adjust the spring compression to match the name plate values.

! **NOTE:** It is necessary to remove the clevis pin (361) and disengage the lever (See Kit #249 Lever Sub-Assembly) and the clevis (364) to adjust the spring compression (Spring set).
15. Position the valve at mid stroke and install the clevis pin snap ring (250)
 - Once you have established the valve is seating and stroking in accordance with the pressure values on the name plate, install the 2nd clevis pin snap ring.
16. Tighten the clevis nut (365) on the clevis (364)
 - Tighten the clevis nut (365) between the clevis (364) and the actuator stem (211).
 - This step locks the actuator stem (211) to the lever (See Kit #249 Lever Sub-Assembly) and the spring range is secure (ie. 3-15 psi or 0.2 to 1.0 bar).
17. Set the OPEN limit stop (See Kit #330 Limit Stop Sub-Assembly) (or hand wheel (See Kit #397 Handwheel Assembly), if it applies)
 - Set the gap between the Open limit stop (or HW) and the roller bearing (See Kit #249 Lever Sub-Assembly).
 - The gap is set at 1 mm.
 - Next, Tighten the clevis nut to lock this stop in place.
18. **Metal Seat:** Set the CLOSED limit stop (See Kit #330 Limit Stop Sub-Assembly) (or hand wheel (See Kit #397 Handwheel Assembly), if it applies)
 - Set the gap between the Closed limit stop (or HW) and the roller bearing (See Kit #249 Lever Sub-Assembly).
- Remember you have already set the open stop (or HW), so you will measure degrees rotation using your stroke plate and stroke indicator.
- Make sure the plug seats in the valve.
- Next set the clevis nut so it will stop on the transfer case.
- Lock the clevis nut in place with the two set screws on either side of the clevis nut.
- The gap is set at 1mm for metal seats.
19. **Soft Seat:** Set the CLOSED limit stop (See Kit #330 Limit Stop Sub-Assembly) (or hand wheel (See Kit #397 Handwheel Assembly), if it applies)
 - When setting the closed limit stop with a soft seat, be careful not to extrude the soft seat material.
 - This is done by slowly stroking the valve to 5% open, and having the limit stop engage the roller bearing (See Kit #249 Lever Sub-Assembly).
 - Remember you have already set the open stop (or HW), so you will measure degrees rotation using your stroke plate and stroke indicator.
 - Using a seat leak fixture, adjust the limit stop as needed to achieve shut off through the seat.
 - If a seat leak fixture is not available, reduce the limit closing stop (or HW) to 3% open. The soft seat is capable of Class VI shutoff.
 - Once the Closing limit stop (or HW) is set, set the clevis nut so it will stop on the transfer case.
 - Lock the clevis nut in place with the two set screws on either side of the jam nut.
 - Do not allow full seat load into the soft seat, it will reduce seat life. Use the limit closing stop to restrict this.
20. Rotate the Hand wheel plate
 - The hand wheel plate is located on the end of the hand wheel drive shaft. Flip this plate over to reflect the correct air action.
21. Mount positioner cover plate
 - Connect the follower pin and the follower arm, then install the (4) positioner cover bolts. (337)
22. Install cover plate
 - Mount the side cover plate and install the (4) cover plate bolts. (337)

Sectional View of Spring Diaphragm Rotary Actuator

! **NOTE:** Item numbers correspond directly to the bill of materials; refer to it for specific part numbers.

Figure 1

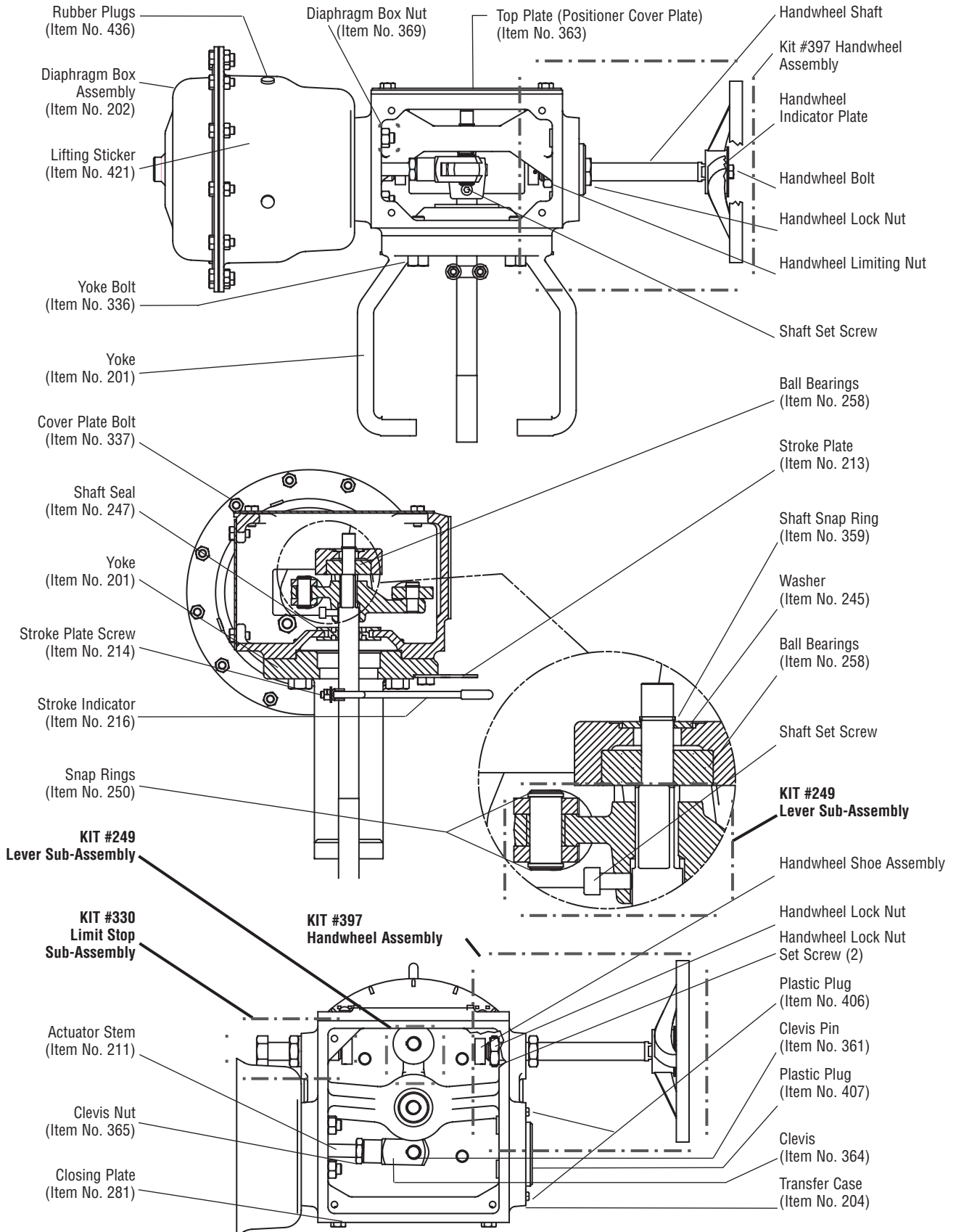

KIT #249 Lever Sub-Assembly

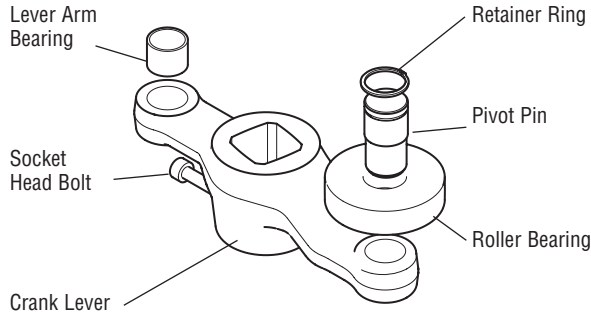

KIT #330 Limit Stop Sub-Assembly (Can be used in place of handwheel)

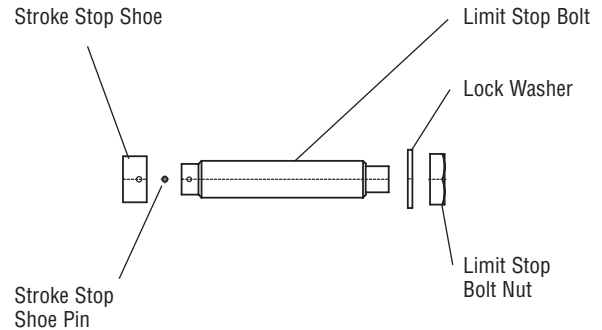

KIT #397 Handwheel Assembly

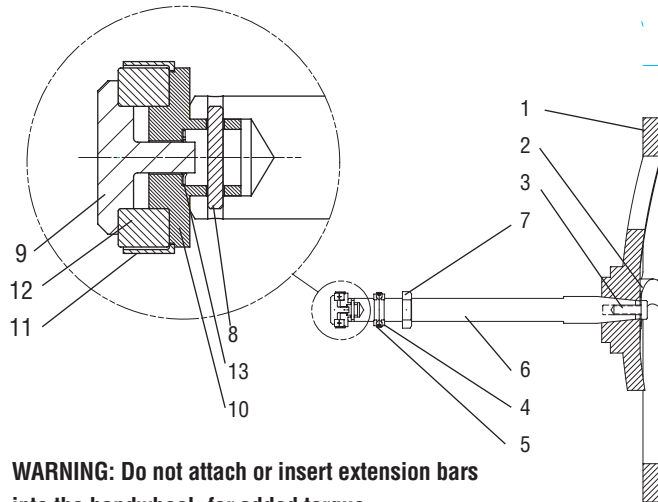

WARNING: Do not attach or insert extension bars into the handwheel, for added torque.

NR 1 & 2
Item # Description

- 1 Handwheel
- 2 Indicator Plate
- 3 Handwheel Bolt
- 4 Handwheel Lock Nut
- 5 Socket Head Capscrew (2)
- 6 Handwheel Shaft
- 7 Handwheel Stop Nut

NR 3
Item # Description

- 1 Handwheel
- 2 Indicator Plate
- 3 Handwheel Bolt
- 4 Handwheel Lock Nut
- 5 Socket Head Capscrew (2)
- 6 Handwheel Shaft
- 7 Handwheel Stop Nut
- 8 Shoe Pin
- 9 Support Pad Shoe
- 10 Base Shoe
- 11 Retainer Shoe
- 12 Ball Bearing
- 13 Retaining Clip

Replacing the Diaphragm, Without Removing the Diaphragm Box

WARNING: The actuator spring is under compression.

1. Position valve vertically

- It is easier to change the diaphragm with the valve in this position.

NOTES:

- The diaphragm can be replaced by itself while the diaphragm box is mounted to the transfer case, or the whole diaphragm box can be removed and replaced.
- If a spring set change is desired, it is recommended that the entire diaphragm box be changed out as described in the “changing the air action” section.

2. Make sure the limit stop (See kit #330 Limit Stop Sub-Assembly) and lever (See Kit #249 Lever Sub-Assembly) are engaged

- Make sure the limit stop is engaged with the lever, so the spring is applying force to the limit stop (or HW).
- This limit stop will hold the diaphragm piston in place, and allow you to change the diaphragm without having to relieve the spring.

3. Remove the small diaphragm case nuts (351) and bolts (335) first

WARNING: Use lubricant on the long threads to avoid galling, simplifies spring compression.

- As a safety precaution, remove the small diaphragm case nuts (351) and bolts (335) first, then remove the thread covers off the long bolts (334).

4. Apply lubricant to the long bolts (334)

- It is recommended to lubricate the long spring compression bolts (334).

- The spring (229) is held in place by the limit stop (See Kit #330 Limit Stop Sub-Assembly), the diaphragm bolting will have little or no load applied to them.
5. Remove the upper diaphragm case (202a)
 - Notice as the cover (202a) is removed, that the piston (227) and diaphragm (225) are held in position by the limit stop (See Kit #330 Limit Stop Sub-Assembly) in the transfer case.
 - This piston can be moved by adjusting the limit stop.
 6. Remove the diaphragm (225) from the piston (227)
 - Peel the old diaphragm (225) off the piston.
 - Notice that the diaphragm (225) is glued to the piston (227).
 7. Clean the glue from the piston
 - Clean the glue off the piston (227).
 - Clean the glue from the O-ring groove in the upper diaphragm case (202).
 8. Apply the glue to the diaphragm (225)
 - Apply Glue to the new diaphragm (225).
 - Place the diaphragm (225) onto the piston (227) and rotate it back and forth several times to evenly distribute the glue over the surface of the piston. Next, remove the diaphragm.
 - Allow the glue to set for 2 or 3 minutes. It will become very sticky.
 - Place diaphragm back onto the piston and line up the bolt holes.
 9. Install a New O-ring (224) in upper diaphragm case (202a)
 - Install a new O-ring in the diaphragm cover.
 - Apply glue to the O-ring while it is in the O-ring groove.
 - Glue used is Scotch-Grip 1022.
 10. Install the diaphragm case (202a)
 - Install the upper diaphragm case (202a).
 - Line up the bolt holes.
 11. Install the nuts (350, 351) and bolts (334, 335) to the diaphragm box
 - Since the spring (229) is held in compression by the limit stop (See Kit #330 Limit Stop Sub-Assembly), this step should be simple.
 - Install the bolting, positioning the (3) spring compression bolts (334) 120 degrees apart.
 - It is recommended to lubricate the long spring compression bolts (334).
 - Readjust limit stop as needed.
 12. Complete

Diaphragm Actuator Orientations

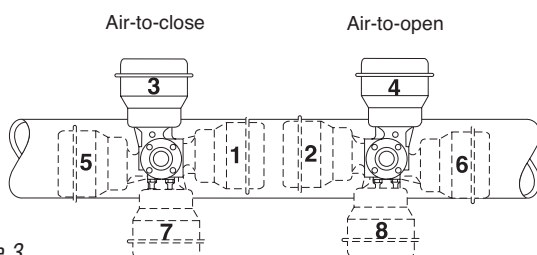

Figure 3

Replacing the Spring or Diaphragm

! GENERAL NOTES

- The diaphragm can be replaced by itself while the diaphragm box is mounted to the transfer case, or the whole diaphragm box can be removed and replaced.
- If a spring set change is desired, it is recommended that the entire diaphragm box be changed out as described in the “changing the air action” section.
- It is possible to change the spring or diaphragm by using the long spring compression bolts to uncompress the spring.

☠ WARNING: Spring is under compression.

1. Position the diaphragm box assembly (202) in a vice
 - Remove the diaphragm box assembly (202) as described in the “Changing air action” section.
 2. Remove the short diaphragm nuts (351) and bolts (335) first
 - You can use a press on top of the upper diaphragm case (202a) to relieve the spring compression.
 - If a press is not available, remove the short diaphragm nuts (351) and bolts (334) first.
 3. Apply a generous amount of lubricant to the (3) long spring compression bolts (334)
 - Apply a generous amount of lubricant to the (3) long spring compression bolts (334).
 - Turn each nut (350), 4 or 5 times and then alternate to the next bolt and nut. Gradually separating the upper and lower diaphragm case halves.
 4. Remove the upper diaphragm case (202a)
 5. Remove the diaphragm (225)
 6. Complete change out of O-ring (224), diaphragm (225) and spring (229) (if needed)
 - Follow steps 6 to 11 in the section titled “Replacing the Diaphragm, Without Removing the Diaphragm Box”.
 - You can now change the spring if desired.
- ⚠ CAUTION: Use caution when compressing the spring.
7. Re-assemble the diaphragm box
 - Re-assembly of the diaphragm box is simplified by using a press to compress the spring and then installing the diaphragm bolting.
 - If a press is not available, then follow steps 1 to 7 in reverse order.

☠ WARNING: Use lubricant on the (3) spring compression bolts (334) prior to compressing spring, to avoid galling.

- Remember to apply a generous amount of lubricant to the long compression bolts prior to compressing the springs with them.

Exploded View of Spring Diaphragm Rotary Actuator

WARNING: Use a press to unload spring, or lubricate the (3) spring compression bolts (334) to unload spring.

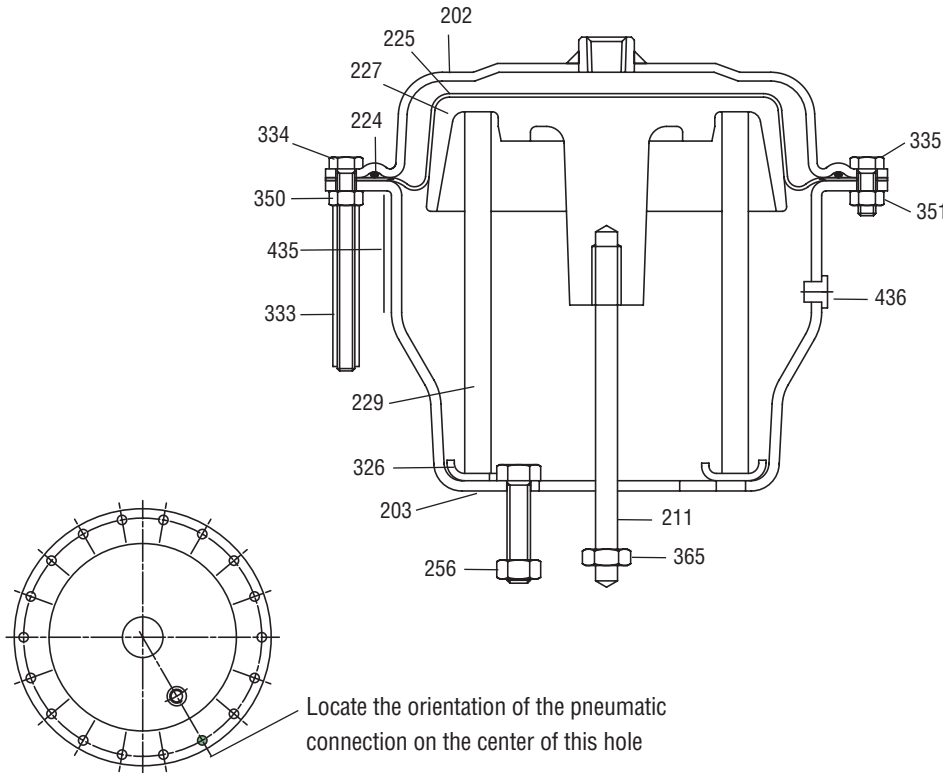

Item #	Description
202a	Upper Diaphragm Case
203	Lower Diaphragm Case
211	Actuator Stem
224	O-ring Seal
225	Diaphragm
227	Piston Diaphragm
229	Spring
256	Nut M8
326	Spring Guide
333	Plastic Tube Protection
334	Bolt M6
335	Bolt M6 X 16
350	Nut M6
351	Nut M6
435	Sticker
436	Plug Rubber
365	Clevis Nut
Kit 500	Guided Diaphragm Assembly
440	Guided Stem
441	Guide Cap
442	Bearing
443	Ret Ring Snap
444	Washer
445	Locknut

NOTE:

1. Item numbers correspond directly to the bill of materials; refer to it for specific numbers.
2. NR2 guided designs are only used in high cycle applications
3. NR3 guided designs are standard with spring set valves of 1.4 to 2.8 bar (20 to 41 psi) or 1.9 to 3.8 bar (28 to 55 psi).

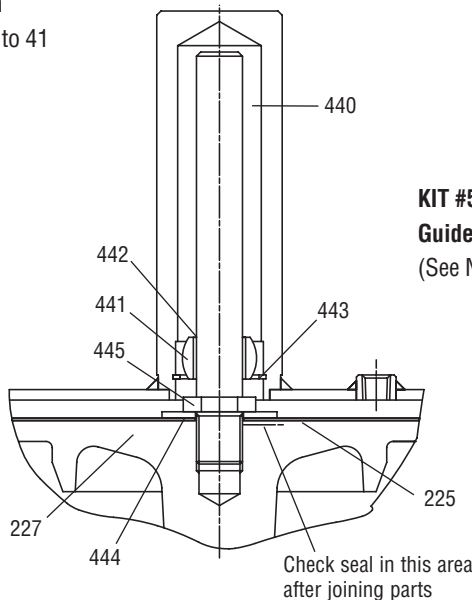

KIT #500
Guided Diaphragm Assembly
(See Notes 2 and 3)

Figure 4

Mounting Orientations

Figure 4

Shaft Upstream

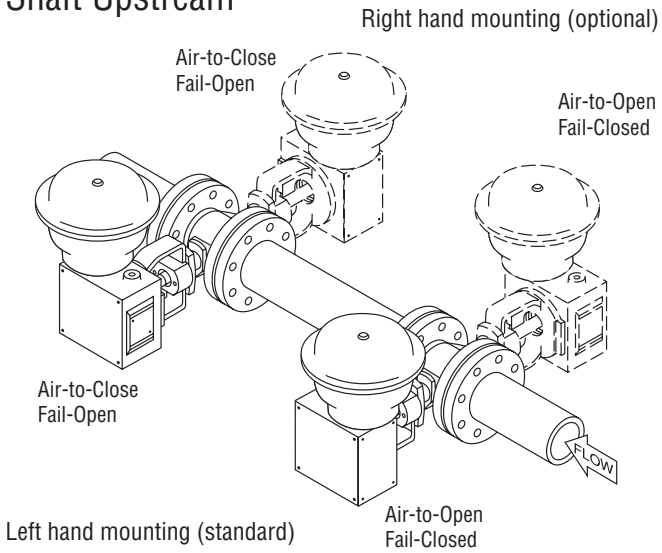

Shaft Downstream

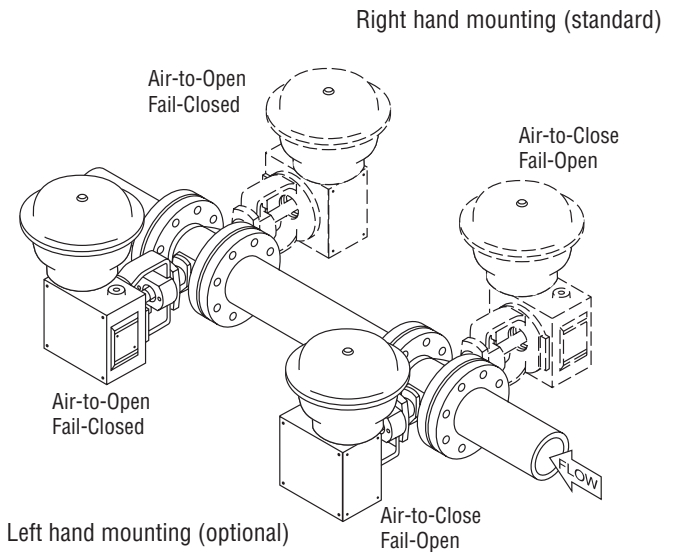

Spring Diaphragm Rotary Actuator (cover removed)

Figure 5

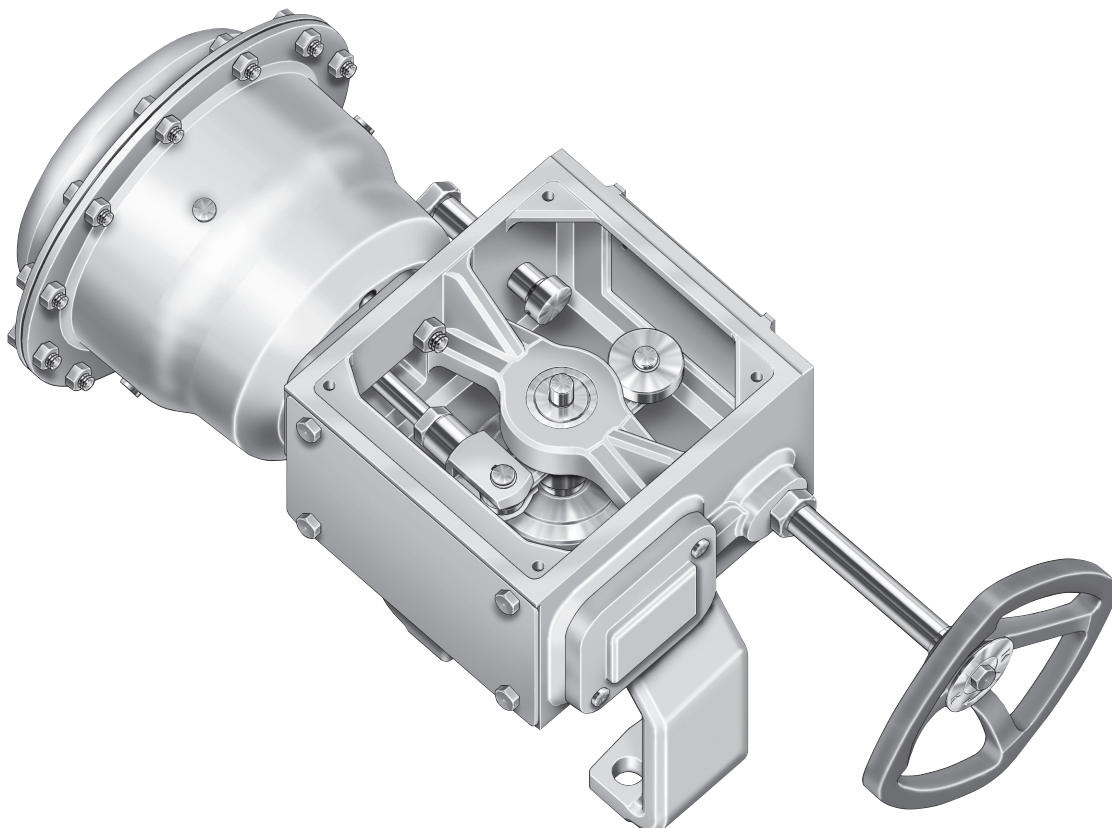

Troubleshooting Rotary Actuators

Failure	Probable Cause	Corrective Action
Actuator operates, shaft does not rotate	1. Broken actuator stem	1. Replace actuator stem
	2. Broken clevis (364) or missing snap rings (250) that allowed pin to move	2. Replace clevis if broken, and make sure the snap rings are snugly placed into the snap ring groove
	3. Torn or broken diaphragm	3. Replace diaphragm
High air consumption or leakage	1. Leaks in the air supply or instrument signal system	1. Tighten connections and replace any leaking lines
	2. Malfunctioning positioner	2. Refer to positioner's maintenance instructions
	3. Broken diaphragm or O-ring seal	3. Replace diaphragm or O-ring seal



United States

Flowserve Corp.
Flow Control
Flowserve Valtek Control Products
1350 N. Mt. Springs Parkway
Springville, UT 84663 USA
Phone: 1 801 489 8611
Fax: 1 801 489 3719

Regional Headquarters

1350 N. Mt. Springs Prkwy.
Springville, UT 84663
Phone: 801 489 8611
Fax: 801 489 3719

12 Tuas Avenue 20
Republic of Singapore 638824
Phone: 65 862 3332
Fax: 65 862 4940

12, av. du Québec, B.P. 645
91965, Courtaboeuf Cedex,
France
Phone: 33 1 60 92 32 51
Fax: 33 1 60 92 32 99

Quick Response Centers

5114 Railroad Street
Deer Park, TX 77536 USA
Phone: 281 479 9500
Fax: 281 479 8511

104 Chelsea Parkway
Boothwyn, PA 19061 USA
Phone: 610 497 8600
Fax: 610 497 6680

1300 Parkway View Drive
Pittsburgh, PA 15205 USA
Phone: 412 787 8803
Fax: 412 787 1944

FCD VLAIM050-01 Printed in USA.

VALTEC NO. 185064

To find your local Flowserve representative

or for more information about Flowserve Corporation, visit
www.flowserve.com.

Flowserve Corporation has established industry leadership in the design and manufacture of its products. When properly selected, this Flowserve product is designed to perform its intended function safely during its useful life. However, the purchaser or user of Flowserve products should be aware that Flowserve products might be used in numerous applications under a wide variety of industrial service conditions. Although Flowserve can (and often does) provide general guidelines, it cannot provide specific data and warnings for all possible applications. The purchaser/user must therefore assume the ultimate responsibility for the proper sizing and selection, installation, operation, and maintenance of Flowserve products. The purchaser/user should read and understand the Installation Operation Maintenance (IOM) instructions included with the product, and train its employees and contractors in the safe use of Flowserve products in connection with the specific application.

While the information and specifications contained in this literature are believed to be accurate, they are supplied for informative purposes only and should not be considered certified or as a guarantee of satisfactory results by reliance thereon. Nothing contained herein is to be construed as a warranty or guarantee, express or implied, regarding any matter with respect to this product. Because Flowserve is continually improving and upgrading its product design, the specifications, dimensions and information contained herein are subject to change without notice. Should any question arise concerning these provisions, the purchaser/user should contact Flowserve Corporation at any one of its worldwide operations or offices.

© 2009 Flowserve Corporation, Irving, Texas, USA. Flowserve is a registered trademark of Flowserve Corporation.