



DOUBLE OFFSET HIGH PERFORMANCE BUTTERFLY VALVES





VAHN-TECH International Inc., headquartered in Toronto, Canada is a unique company within the Flow Control Industry.

- ✳ 'vt' brand = high quality certified products (API, NSF, CSA, WRAS etc.)
- ✳ Valves, Actuators and Accessories – all 'vt' branded
- ✳ Width and Depth of Product Offerings
- ✳ Flexibility to customize products to customer needs
- ✳ Specialized user-friendly products including large sizes
- ✳ Quick Response
- ✳ Reduced Delivery times
- ✳ Efficient after sales service
- ✳ Competitive Pricing

VAHN-TECH International Inc. is a customer focused organization based on “Value-Add” and “Quality Service” principles. Achieving long term partnership with our customers and being their supplier of choice is our prime mission.

We develop, manufacture and market VAHN-TECH (vt) branded Valves, Actuators, Automatic Control Valves and Accessories for variety of Industrial Applications. Our product range includes:



Oil and Gas



Water and Sewage, Desalination



Chemicals



Paper and Pulp



Irrigation



Power Plants



Various Industrial Applications

We can supply all types of valves with following materials of construction like:

Ductile Iron, Cast Iron, Carbon Steel, Stainless Steel – SS304, SS304L, SS316, SS316L, Duplex Stainless Steel, Super Duplex, Alloy, Monel and Inconel with variety of seating and stem configurations.



1. Design Standards

Applicable Standards	
Design Standard:	API 609
End Connection:	ASME B16.5 / ASME B16.47 / ASME B16.25
Face-to-Face:	API 609 / ASME B16.10
Test & Inspection:	API 598
Fire-Safe:	API 607
Low Fugitive Emission:	ISO 15848-2015
NACE:	MR 0715

2. Design Features

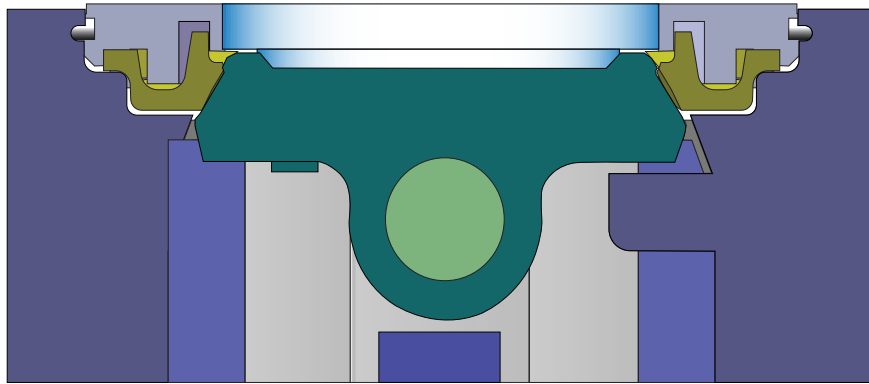

- ✳ Contact free sealing between seat and disc during open / close or interim positions
- ✳ No abrasion point either on the upper or lower parts of seat as well.
- ✳ Lower Torque Values resulting in low torque gear operators or actuators.
- ✳ Seat shape specially designed with unique dynamic load PTFE seal providing good elasticity and high reliability.
- ✳ Sealing can be maintained without the need of adding O-Ring or metal backing ring.
- ✳ The lip type sealing structure can compensate for the changes of temperature and pressure during operation.
- ✳ Bubble tight leakage tightness in both directions.
- ✳ Low maintenance requirement with extended service life in high cycle operation. Seat replacement can be done without disassembling the valve disc and shaft.
- ✳ Superior flow characteristic in throttling applications with linear flow characteristic curve.
- ✳ Fire-safe design per API 607.
- ✳ Stem shaft is designed with anti-blowout structure to prevent stem injection in case of pressure surge.

3. Available End Connections

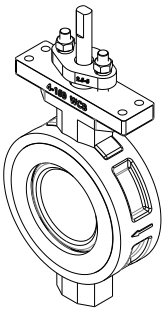

Wafer

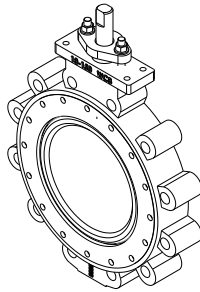

Lug

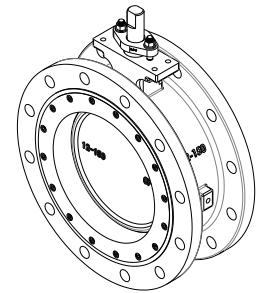

Double Flange

4. Material of Construction

No.	Part Name	Carbon Steel Configuration	Stainless Steel Configuration
1	Valve Body	ASTM A216 WCB	ASTM A351 CF8
2	Butterfly Disc	ASTM A351 CF8	ASTM A351 CF8
3	Seat Retainer	ASTM A351 CF8	ASTM A351 CF8
4	Insert	RPTFE or PPL	RPTFE or PPL
5	Valve Seat	Carbon Steel	SS316
6	Shaft Collar	SS316	SS316
7	Pin	17-4PH	17-4PH
8	Axle Sleeve	SS316+RPTFE	SS316+RPTFE
9	Packing Pad	SS316	SS316
10	Packing	RPTFE or Graphite	RPTFE or Graphite
11	Packing Gland	ASTM A216 WCB	ASTM A351 CF8
12	Washer	Carbon Steel	Stainless Steel
13	Bolts	Carbon Steel	Stainless Steel
14	Nuts	Carbon Steel	Stainless Steel
15	Shaft	17-4PH	17-4PH

*Contact us for other material configuration.

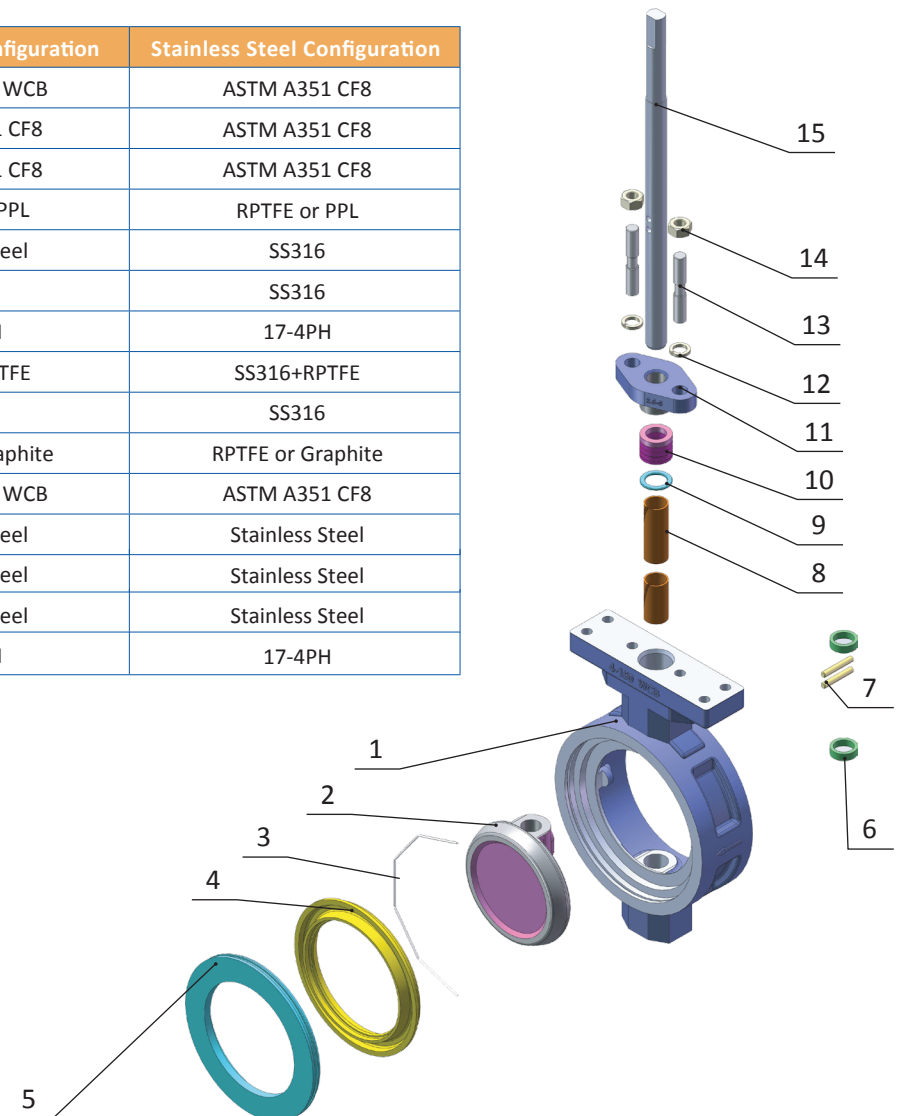

5. Dimensions (mm)

Wafer Type

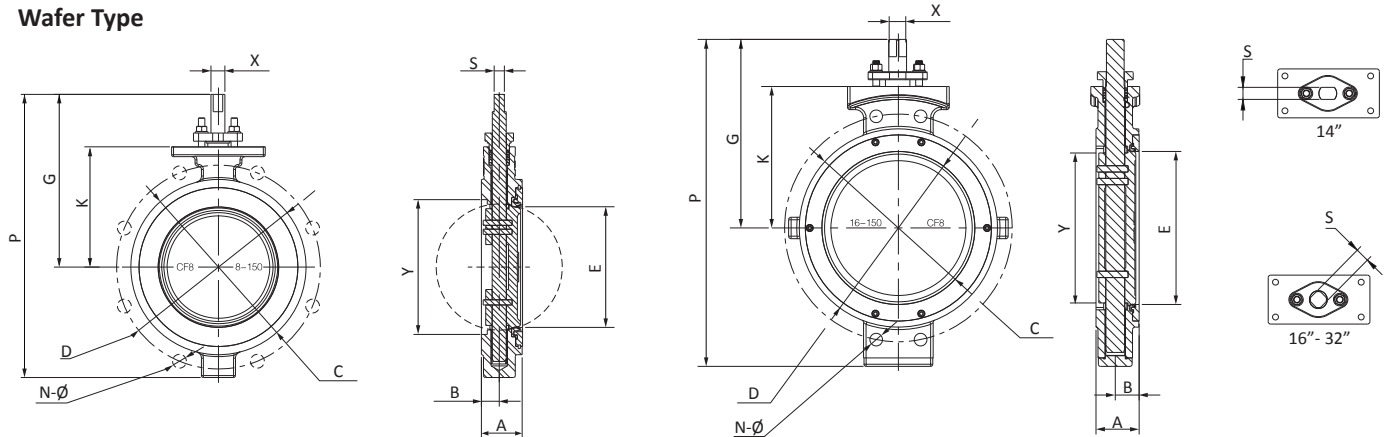

Class 150

NPS	DN	A	B	C	D	E	G	K	Ø	N	P	S	X	Y*	Weight (Kg)
2"	50	43.3	23.3	96	-	38	124.3	80	-	-	186.3	7	24	50	32
2 1/2"	65	49	27	119	-	59	194	111	-	-	275	11.2	14.8	48	5
3"	80	49	27	132	-	73	203	121	-	-	316	11.2	14.8	74	6
4"	100	54	30	157	-	95	216	133	-	-	341	11.2	14.8	97	8
5"	125	64	30	186	-	111	217	135	-	-	362	11.2	14.8	111	12
6"	150	57	33	216	-	142	235	152	-	-	378	14	18	146	13
8"	200	64	36	270	-	188	270	187	-	-	441	15.9	21.9	194	20
10"	250	71	41	324	-	236	329	232	-	-	530.6	20.6	28	243	35
12"	300	81	48	381	-	282	357	260	-	-	595.5	23.8	33.3	289	51
14"	350	92	52	413	476	314	425	315	Ø29	0	710	28.5	37	318	82
16"	400	102	56	470	540	363	444	333	Ø30	4	767	33.5	42	365	115
18"	450	114	67	533	578	414	466	355	Ø33	4	812	41.5	47	416	156
20"	500	127	7	584	635	456	492	378	Ø30	4	879	41.4	50	454	199
24"	600	154	76	692	749	549	610	480	Ø33	4	1094	51	64	542	333
26"	650	164.6	86.5	749	806.5	549	620	480	Ø33	4	1103	51	64	542	371
30"	750	167	87	857	914	702	697	570	Ø33	4	1307	51	66.8	711	594
32"	800	190	87	905	977.9	702	697	570	Ø39	4	1307	51	66.8	711	638

Class 300

NPS	DN	A	B	C	D	E	G	K	Ø	N	P	S	X	Y*	Weight (Kg)
2"	50	43.3	23.3	96	-	38	124.3	80	-	-	186.3	7	24	50	3.2
2 1/2"	65	49	27	119	-	59	194	111	-	-	275	11.2	14.8	48	5
3"	80	49	27	132	-	73	203	121	-	-	316	11.2	14.8	74	6
4"	100	54	30	157	-	95	216	133	-	-	341	11.2	14.8	97	8
5"	125	64	30	186	-	111	217	135	-	-	362	11.2	14.8	111	12
6"	150	59	34	216	-	142	257	175	-	-	413	15.9	21.9	146	15
8"	200	73	40	270	-	188	306	213	-	-	495	20.6	28	194	27
10"	250	83	44	324	387	236	353	254	Ø27	4	592	23.8	33.3	243	48
12"	300	92	50	381	451	282	389	283	Ø30	4	675	28.7	37	289	66
14"	350	118	59	413	514	314	427	325	Ø30	4	738	41.4	50	289	167
16"	400	133	62	470	572	363	452	350	Ø33	4	791	41.4	50	346	195
18"	450	149	75	533	629	414	542	424	Ø33	4	955	51	64	392	324
20"	500	162	81	584	686	455	576	446	Ø33	4	1075	51	65	433	406
24"	600	184	92	692	813	549	646	501	Ø39	4	1151	51	65	524	631

Lug Type

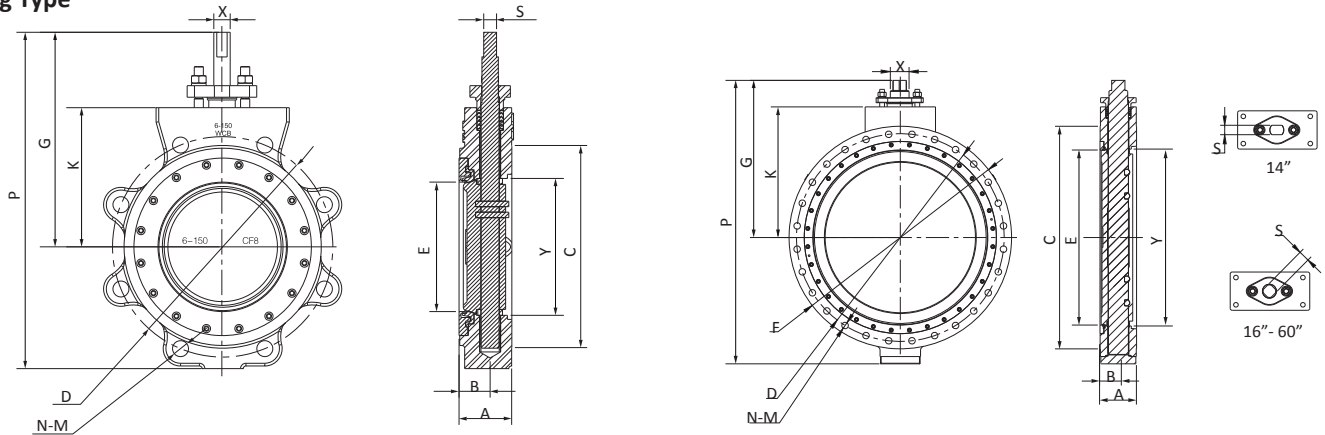

Class 150

NPS	DN	A	B	C	D	E	F	G	K	M	N	P	S	X	Y*	Weight (Kg)
2 1/2"	65	49	27	105	140	59	178	194	111	16	4	275	11	16	48	6.4
3"	80	49	27	132	152	73	191	203	121	16	4	316	11	16	74	8
4"	100	54	30	157	191	95	229	216	133	16	8	341	11	16	97	11
5"	125	64	30	186	216	111	264	217	135	20	8	341	11	16	111	18
6"	150	57	33	216	241	142	279	235	152	20	8	384	13	19	146	16.2
8"	200	64	36	270	298	188	343	270	187	20	8	464	16	22	194	31
10"	250	71	41	324	362	236	406	325	232	22	12	560	21	29	243	42.2
12"	300	81	48	381	432	282	483	359	260	24	12	632	24	35	289	64.8
14"	350	92	52	413	476	314	533	394	309	27	12	705	24	41	318	105
16"	400	102	56	470	540	363	597	446.4	335.4	27	16	766.7	41	48	365	163
18"	450	114	67	533	578	414	635	449	356	30	16	802	41	54	416	205
20"	500	127	67	584	635	456	699	467	378	30	20	842	41	60	454	270
24"	600	154	76	692	749	549	813	607	490	33	20	1161	51	70	542	437
30"	750	167	87	857	914	702	984	697	570	33	28	1307	51	89	711	741
36"	900	184	92	1108	1086	886	1168	794	660	39	32	1432	51	102	876	1189

6. Technical Information

a. Flow Characteristics

The flow coefficient of 150lbs and 300lb butterfly valves is listed in the following table. Cv value indicates water flow per minute that passes through the fully opened valve when the differential pressure is 1psi (0.07bar) and the temperature is 60°F (15.6°C), and its unit is USgal/min.

Cv Values

Class 150

NPS	DN	Cv
2 1/2"	65	78
3"	80	165
4"	100	400
5"	125	650
6"	150	1,050
8"	200	2,200
10"	250	3,300
12"	300	5,100
14"	350	5,800
16"	400	8,000
18"	450	10,500
20"	500	1,400
24"	600	21,600

Class 300

NPS	DN	Cv
3"	80	165
4"	100	400
6"	150	1,050
8"	200	1,800
10"	250	3,150
12"	300	4,750
14"	350	5,200
16"	400	6,900
18"	450	9,300
20"	500	11,300
24"	600	18,500
30"	750	29,100
36"	900	47,500

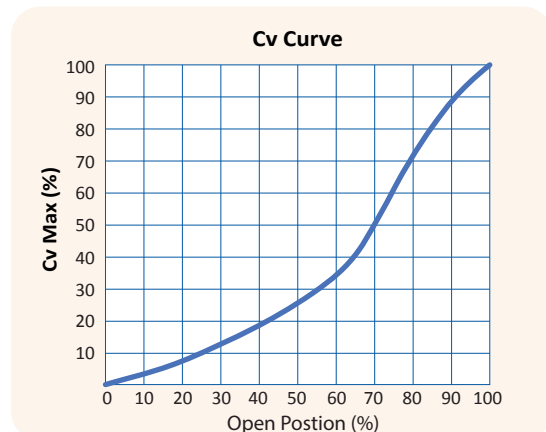

b. Torque Values

Torque in Nm at given closing differential pressure (bar).

Class 150 - Shaft Downstream, Standard Seats				
NPS	DN	6.9bar	13.8bar	19.7bar
2-1/2"	65	29	31	33
3"	80	34	37	39
4"	100	47	53	58
5"	125	65	76	86
6"	150	97	113	126
8"	200	164	193	217
10"	250	222	274	318
12"	300	290	390	475
14"	350	491	684	849
16"	400	628	876	1087
18"	450	816	1144	1423
20"	500	1098	1546	1926
24"	600	1673	2384	2983

Class 150 - Shaft Downstream, Fire Safe Seats				
NPS	DN	6.9bar	13.8bar	19.7bar
2-1/2"	65	57	61	64
3"	80	72	7	81
4"	100	91	100	108
5"	125	132	155	174
6"	150	178	206	230
8"	200	296	347	391
10"	250	452	550	635
12"	300	589	862	1010
14"	350	819	1028	1205
16"	400	963	1247	1489
18"	450	1315	1857	2318
20"	500	1885	2685	3364
24"	600	2779	3661	2983

Class 300 - Shaft Downstream, Standard Seats				
NPS	DN	20.7bar	41.4bar	51bar
3"	80	42	42	51
4"	100	70	70	88
6"	150	161	161	214
8"	200	313	313	422
10"	250	480	480	664
12"	300	667	667	913
14"	350	1117	1117	1627
16"	400	1340	1340	1946
18"	450	1734	1734	2520
20"	500	2314	2314	3369
24"	600	3131	3131	4549

Class 300 - Shaft Downstream, Fire Safe Seats				
NPS	DN	20.7bar	41.4bar	51bar
3"	80	77	83	86
4"	100	117	149	164
6"	150	256	350	394
8"	200	424	591	669
10"	250	629	865	975
12"	300	1119	1668	1924
14"	350	1250	1877	2169
16"	400	1586	2481	2899
18"	450	2685	4556	5429
20"	500	3796	6481	7734
24"	600	5966	10033	1131

c. Pressure and Temperature Ratings

Seat Rated Value

The seat rated values indicated on the curve are only for the seat. It is the differential pressure between the two ends of the butterfly valve when the valve is fully closed. These rated values can serve as use guide under general conditions. According to past experience, the rated values for improved and changed other seat materials may be higher.

Body Rated Value

The maximum working pressure of body and testing pressure of body of various materials are listed in the body pressure ratings table. The actual working pressure in the working conditions shall be decided according to the seat rated values.

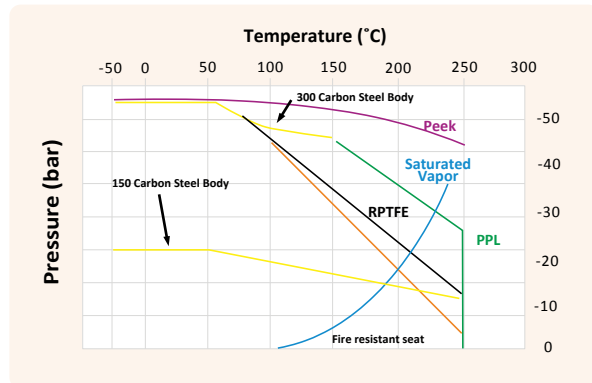

Body Pressure/Temperature rating (Class 150, bar)				
Temperature (°C)	Carbon Steel	Stainless Steel	Alloy 20	Monel
-20 to 38	19.7	19	15.8	15.8
93	17.9	16.5	13.8	13.8
149	15.8	14.8	12.4	13.1
204	13.8	13.4	11.0	12.8
260	11.7	11.7	10.3	11.7

Body Pressure/Temperature rating (Class 300, bar)				
Temperature (°C)	Carbon Steel	Stainless Steel	Alloy 20	Monel
-20 to 38	51	41.4	41.4	41.1
93	46.5	35.9	35.9	36.5
149	45.2	32.1	32.1	34.1
204	43.8	29.0	29.0	33.1
260	41.4	26.9	26.9	32.8

PRODUCT SELECTION

VT - DOBF - XX - X - XX - XX - XX - XX - XX - X

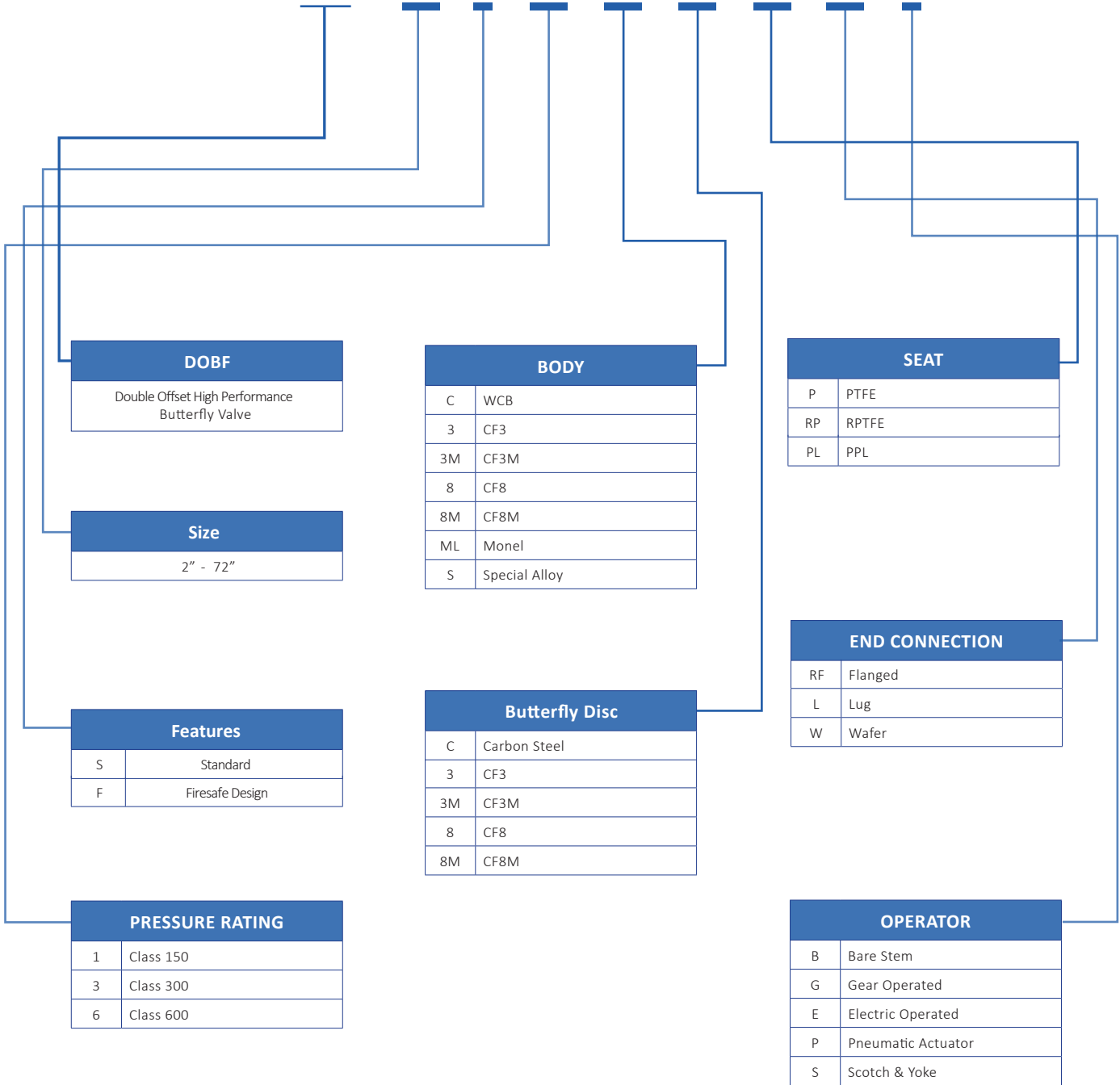



VAHN-TECH International Inc.

2608-88, Bluejays Way, Toronto, Ontario, M5V 0L7, Canada
Tel.: +1 416 342 0001 E-mail: info@vahn-tech.com

www.vahn-tech.com