



**BUTTERFLY VALVES
(PTFE LINED)**



Intertek



VAHN-TECH International Inc., headquartered in Toronto, Canada is a unique company within the Flow Control Industry.

- ✳ 'vt' brand = high quality certified products (API, NSF, CSA, WRAS etc.)
- ✳ Valves, Actuators and Accessories – all 'vt' branded
- ✳ Width and Depth of Product Offerings
- ✳ Flexibility to customize products to customer needs
- ✳ Specialized user-friendly products including large sizes
- ✳ Quick Response
- ✳ Reduced Delivery times
- ✳ Efficient after sales service
- ✳ Competitive Pricing

VAHN-TECH International Inc. is a customer focused organization based on “Value-add” and “Quality Service” principles. Achieving long term partnership with our customers and being their supplier of choice is our prime mission.

We develop, manufacture and market VAHN-TECH (vt) branded Valves, Actuators, Automatic Control Valves and Accessories for variety of Industrial Applications. Our product range includes:



Oil and Gas



Water and Sewage,
Desalination



Chemicals



Paper and Pulp



Irrigation



Power Plants



Various
Industrial Applications

We can supply all types of valves with following materials of construction like:

Ductile Iron, Cast Iron, Carbon Steel, Stainless Steel – SS304, SS304L, SS316, SS316L, Duplex Stainless Steel, Super Duplex, Alloy, Monel and Inconel with variety of seating and stem configurations.



PTFE LINED Butterfly Valves Design Features

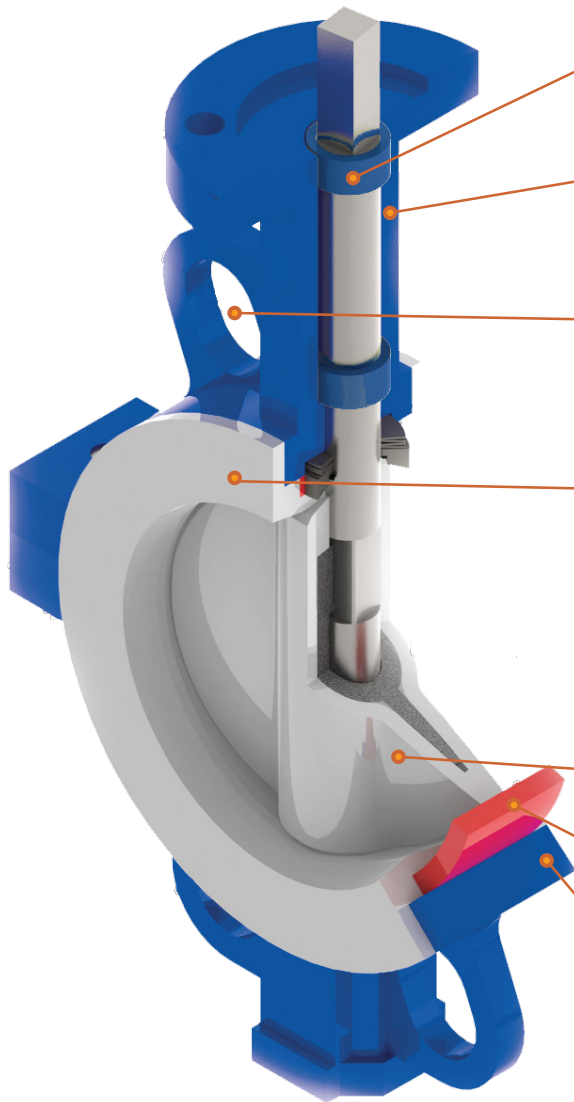

Top Stem Bushing

Retained by a stainless steel ring, is provided to absorb actuator side thrust and standards or PTFE as an option.

Neck

An extended neck design for all valve sizes allows for 2" of piping insulation and provides easy access for mounting actuators.

Flange Locating Holes

Provides quick and precise alignment during valve installation eliminating disc interference with adjacent pipe I.D.

Seat Design

The seat design reduces seating unseating torque and, at the same time, reduces wear on the contacting parts. Curvatures machined into the inner seat area minimize contact forces between the disc and seat as the disc approaches, or opens from, the closed position. This unique seat geometry permits lower torques and reduces seat wear.

Disc

The PTFE disc has 1/8" (3 mm) minimum thickness of pure PTFE encapsulated over Stainless Steel.

Resilient Seat

A resilient seat energizer extends completely around the seat, including the disc hub. This provides uniform force sufficient for bubble-tight shut off.

Body

A two-piece wafer of lug style epoxy coated. Complies fully with ASME Class 150 and DIN 3840 pressure rating standards for hydrostatic requirements.

Standard Specifications

Design Standard	: API 609
Face-to-Face Standard	: API 609
Connection Standard	: ASME B16.5 / EN 1092-2 / JIS B2220 10K / AS 2129
Applicable Temperature	: -29°C to 200°C
Test Standard	: API 598

- * Absolute tight sealing with flow in either direction.
- * The valve body and disc are accurately machined which results in low operating torque and long service life and reliability.
- * PTFE liner seated prevents corrosion and guarantees long service life.
- * Can be disassembled, material specific recycling possible
- * Can be installed at the end of pipe for lugged type butterfly valve

PTFE Lined Butterfly Valves

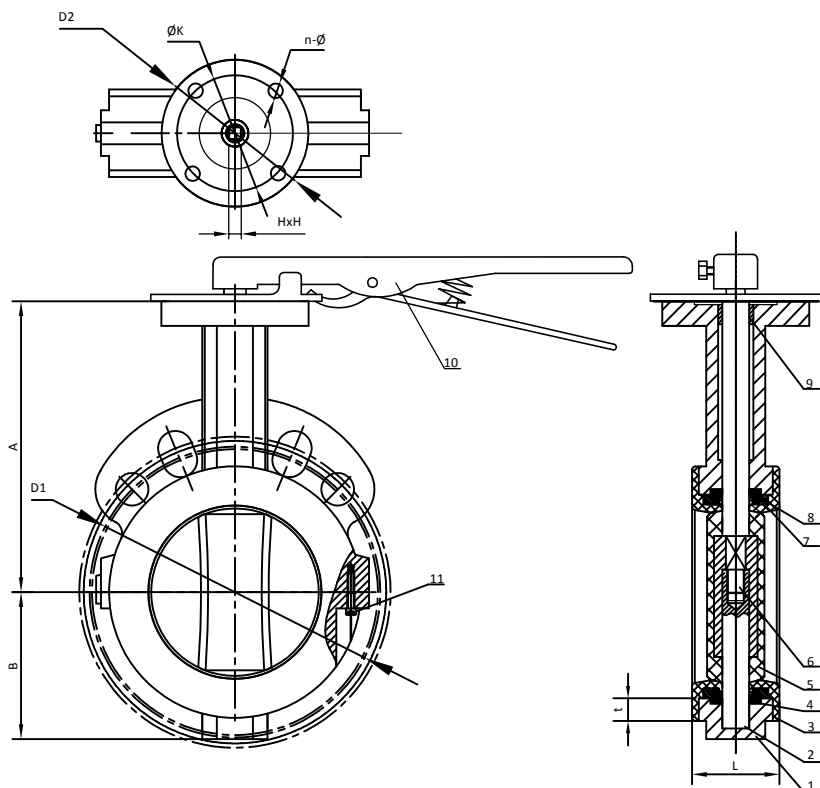

Parts List & Materials

No	Parts Name	Materials
1	Body	Ductile Iron
2	Lower Shaft	SS410
3	Seat	PTFE
4	Butterfly Spring	Spring Steel
5	Disc	PTFE + CF8M
6	Upper Shaft	SS410
7	Seat Energizer	Silicone
8	Pressing Sleeve	Stainless Steel
9	Bushing	PTFE
10	Lever	Malleable Iron
11	Bolt	SS304

unit: mm

Size		D1	L	A	B	H x H	D2	K	n - ø	t	ISO 5211
inch	mm										
2"	50	120.7	43	140	70	9 x 9	90	70	4 - 10	12	F07
2 1/2"	65	139.7	46	150	80	9 x 9	90	70	4 - 10	14	F07
3"	80	152.4	46	160	85	9 x 9	90	70	4 - 10	14	F07
4"	100	190.5	52	178	110	11 x 11	90	70	4 - 10	14	F07
5"	125	215.9	56	190	120	14 x 14	90	70	4 - 10	16	F07
6"	150	241.3	56	200	135	14 x 14	90	70	4 - 10	17	F07
8"	200	298.5	60	240	170	17 x 17	125	102	4 - 12	21	F10
10"	250	361	68	273	195	22 x 22	125	102	4 - 12	22	F10
12"	300	431.8	78	310	220	22 x 22	125	102	4 - 12	22	F10

PTFE Lined Butterfly Valves

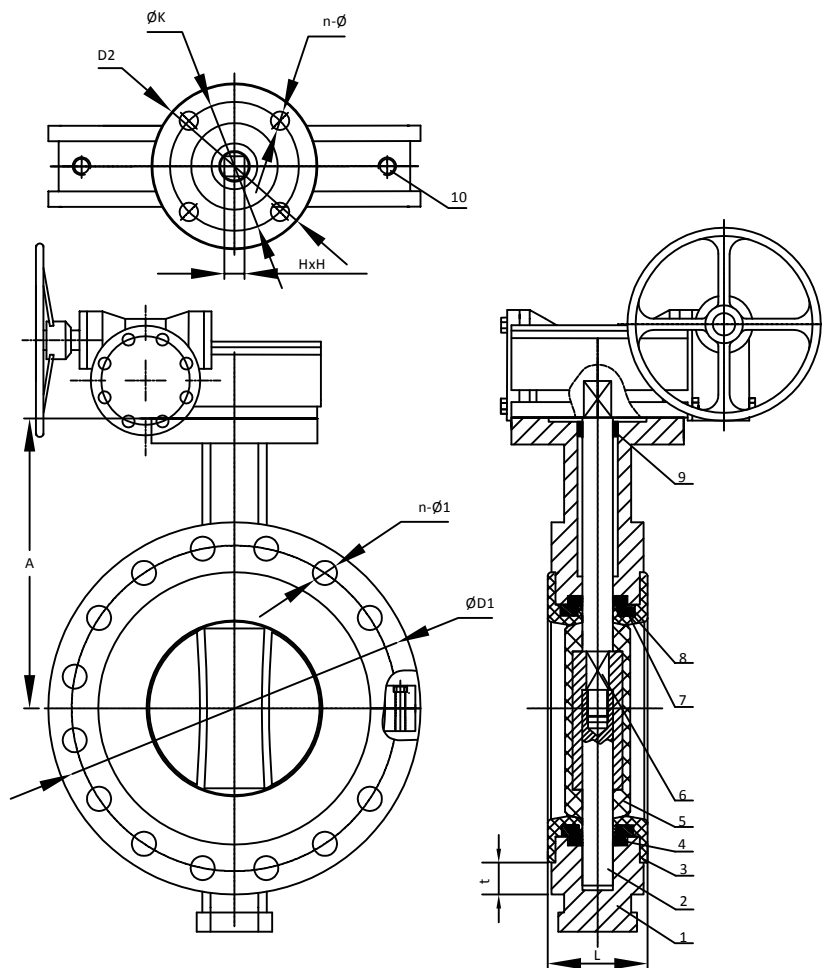

Parts List & Materials

No	Parts Name	Materials
1	Body	Ductile Iron
2	Lower Shaft	SS410
3	Seat	PTFE
4	Butterfly Spring	Spring Steel
5	Disc	PTFE + CF8M
6	Upper Shaft	SS410
7	Seat Energizer	Silicone
8	Pressing Sleeve	Stianless Steel
9	Bushing	PTFE
10	Bolt	SS304

unit: mm

Size		D1	L	A	B	H x H	D2	K	n - ϕ	t	ISO 5211
inch	mm										
14"	350	476.3	78	346	70	22 x 22	125	102	4 - 12	39	F10
16"	400	539.8	102	375	80	27 x 27	175	40	4 - 18	43	F14
18"	450	577.9	114	406	85	27 x 27	175	140	4 - 18	28	F14
20"	500	635.0	127	438	110	36 x 36	210	165	4 - 22	30	F16
24"	600	749.3	154	495	120	36 x 36	210	165	4 - 22	31	F16

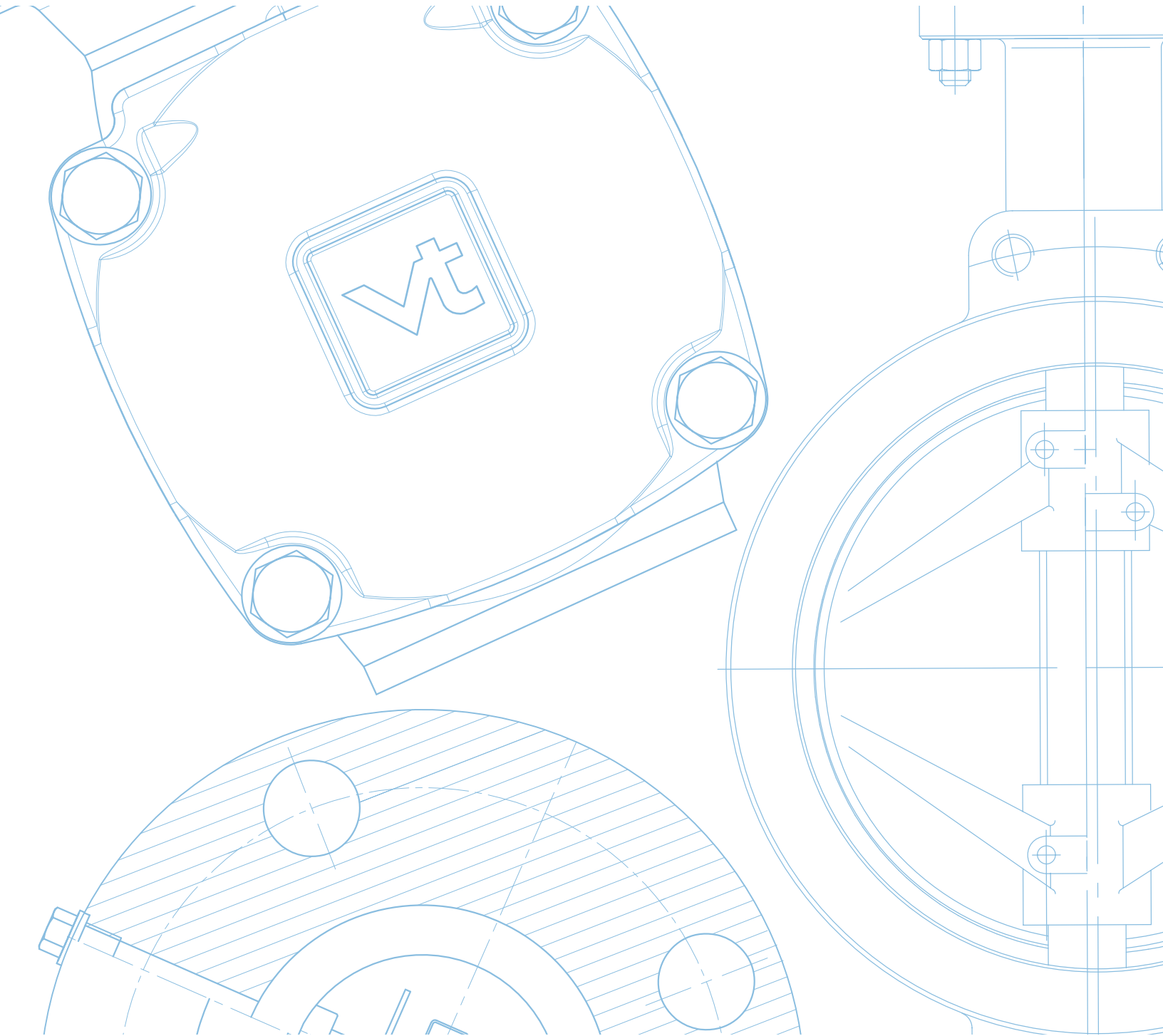

VAHN-TECH International Inc.
2608-88, Bluejays Way, Toronto, Ontario, M5V 0L7, Canada
Tel.: +1 416 342 0001 E-mail: info@vahn-tech.com

www.vahn-tech.com