



## LUG TYPE BUTTERFLY VALVES





**VAHN-TECH International Inc.**, headquartered in Toronto, Canada is a unique company within the Flow Control Industry.

- ✳ 'vt' brand = high quality certified products (API, NSF, CSA, WRAS etc.)
- ✳ Valves, Actuators and Accessories – all 'vt' branded
- ✳ Width and Depth of Product Offerings
- ✳ Flexibility to customize products to customer needs
- ✳ Specialized user-friendly products including large sizes
- ✳ Quick Response
- ✳ Reduced Delivery times
- ✳ Efficient after sales service
- ✳ Competitive Pricing

**VAHN-TECH International Inc.** is a customer focused organization based on “Value-add” and “Quality Service” principles. Achieving long term partnership with our customers and being their supplier of choice is our prime mission.

We develop, manufacture and market VAHN-TECH (vt) branded Valves, Actuators, Automatic Control Valves and Accessories for variety of Industrial Applications. Our product range includes:



Oil and Gas



Water and Sewage,  
Desalination



Chemicals



Paper and Pulp



Irrigation



Power Plants



Various  
Industrial Applications

We can supply all types of valves with following materials of construction like:

Ductile Iron, Cast Iron, Carbon Steel, Stainless Steel – SS304, SS304L, SS316, SS316L, Duplex Stainless Steel, Super Duplex, Alloy, Monel and Inconel with variety of seating and stem configurations.



## Rubber Seated Butterfly Valves

### Design Features

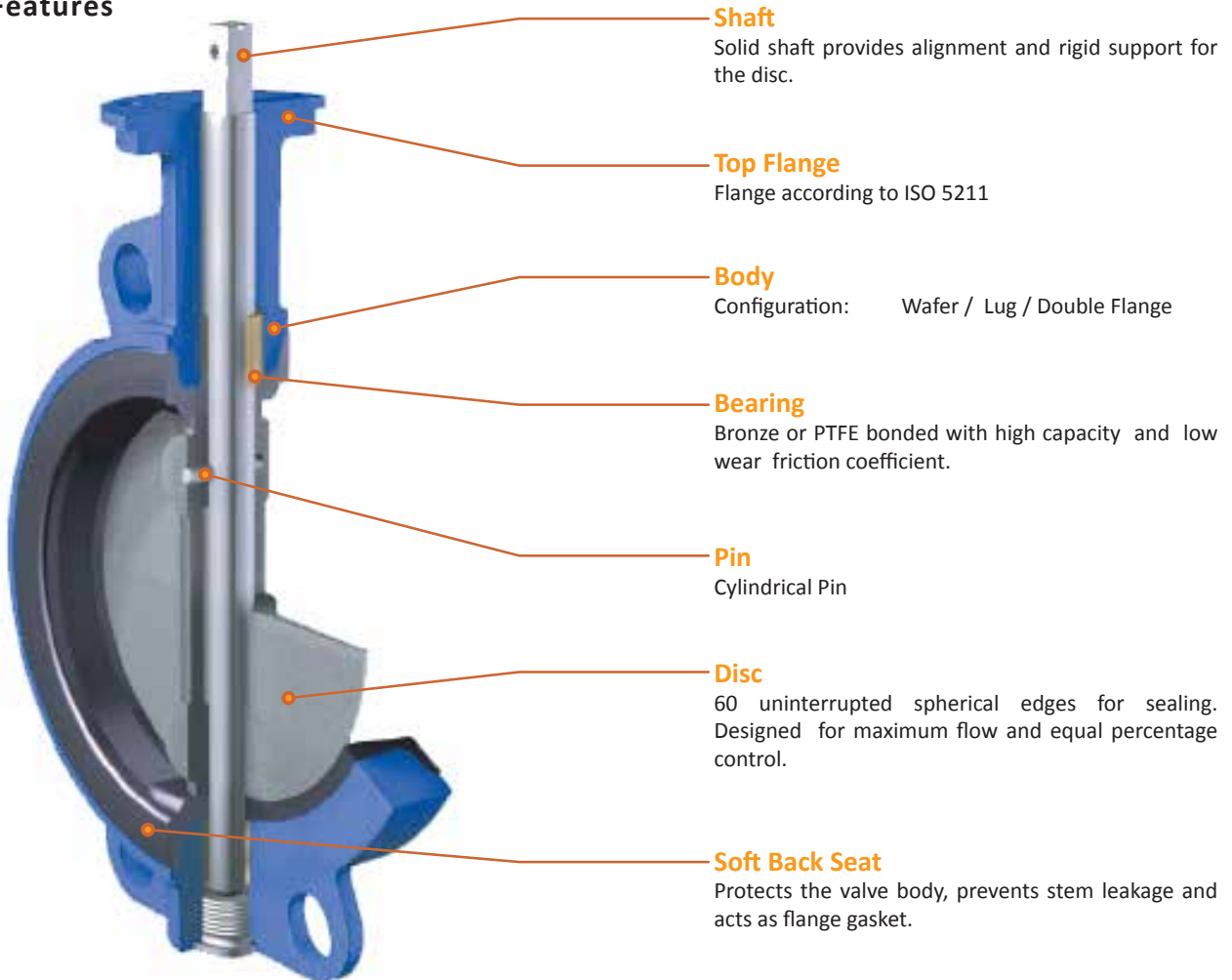

1. Polished disc edge provides full concentric sealing with lower torque and long service life.
2. Bi-directional Sealing which is suitable for normal flow and contraflow working condition.
3. Cylindrical pin enables a vibration free connection between the shaft and the disc.
4. Rubber seats vulcanized on the body in such a way that the seats protrude a little outside the valve body (this eliminates need for a flange gasket).
5. Replaceable seal held with seat ring on the disc allows easy maintenance.

The design features a one - piece body for minimum weight and maximum strength, the back seat allows easy installation, reliable operation.

Resilient seated butterfly valves are applicable in a wide variety of industry such as:

- |                              |                                  |
|------------------------------|----------------------------------|
| → Agriculture                | → Drinking Water and Waste Water |
| → Oil and Gas                | → District Cooling & HVAC        |
| → Food and Beverages         | → Power and Mining               |
| → Chemical and Petrochemical | → Marine                         |

Not recommended as replacement of blind flange at full rated pressure.

## Flow Performance

### Definition of Cv Value (Flow Coefficient)

The valve Cv is the flow rate of pure water at 60°F passing through the valve when the disc is fully opened and the differential pressure between the two ends of the valve is 1 lbf/in<sup>2</sup>.

V: Max. Flow (US gal/min)

G: Specific Gravity (1 for water)

ΔP: Differential in Valve (lbf/in<sup>2</sup>)

### Definition of Kv Value (Flow Coefficient)

The valve Kv is the flow rate of pure water at 15°C passing through the valve when the disc is fully opened and the differential pressure between the two ends of the valve is 1 bar.

Q: Max. Flow (m<sup>3</sup>/h)

G: Medium Density (g/cm<sup>3</sup>)(1 for water)

ΔP: Differential Pressure in Valve  
(100 kpa) ie. bar

### CV Value of Concentric Butterfly Valves

Size		10°	20°	30°	40°	50°	60°	70°	80°	90°
inch	mm									
2"	50	0.06	3	7	15	27	44	70	105	115
2 1/2"	65	0.1	6	12	25	45	75	119	178	196
3"	80	0.2	9	18	39	70	116	183	275	302
4"	100	0.3	17	36	78	139	230	364	546	600
5"	125	0.5	29	61	133	237	392	620	930	1022
6"	150	0.8	45	95	205	366	605	958	1437	1579
8"	200	2	89	188	408	727	1202	1903	2854	3136
10"	250	3	151	320	694	1237	2047	3240	4859	5340
12"	300	4	234	495	1072	1911	3162	5005	7507	8250
14"	350	6	338	715	1549	2761	4568	7230	10844	11917
16"	400	8	464	983	2130	3797	6282	9942	14913	16388
18"	450	11	615	1302	2822	5028	8320	13168	19752	21705
20"	500	14	791	1647	3628	6465	10698	16931	25396	27908
24"	600	22	1222	2587	5605	9989	16528	26157	39236	43116
28"	700	36	1813	3639	6636	10000	14949	22769	34898	49500
30"	750	37	2080	4406	9546	17010	28147	44545	66818	73426
32"	800	45	2387	4791	8736	13788	20613	31395	48117	38250
36"	900	260	3050	6730	12740	20220	32500	52500	79600	87500
40"	1000	84	4183	8395	15307	24159	36166	55084	84425	119750
42"	1050	350	4095	9040	17108	27150	43640	70500	106890	117500
48"	1200	455	5365	11840	22400	30600	51200	92300	140000	154000

### Kv Value of Concentric Butterfly Valves

Size		10°	20°	30°	40°	50°	60°	70°	80°	90°
inch	mm									
2"	50	0.05	2.6	6	13	23	38	60	90	99
2 1/2"	65	0.09	5	10	21	39	64	102	153	168
3"	80	0.17	8	15	33	60	99	157	236	259
4"	100	0.26	15	31	67	119	197	312	468	514
5"	125	0.43	25	52	114	203	336	531	797	876
6"	150	0.69	39	81	176	314	518	821	1231	1353
8"	200	1.7	76	161	350	623	1030	1631	2446	2687
10"	250	2.6	129	274	595	1060	1754	2776	4164	4576
12"	300	3	201	424	919	1638	2710	4289	6433	7069
14"	350	5	290	613	1327	2366	3914	6195	9292	10212
16"	400	7	398	842	1825	3254	5383	8519	12779	14043
18"	450	9	527	1116	2418	4308	7129	11284	16925	18599
20"	500	12	678	1411	3109	5540	9167	14508	21762	23914
24"	600	19	1047	2217	4803	8560	14163	22414	33621	36946
28"	700	31	1554	3118	5686	8569	12810	19511	29904	42416
30"	750	32	1782	3775	8180	14576	24119	38171	57256	62919
32"	800	39	2045	4105	7486	11815	17663	26902	41231	32776
36"	900	223	2614	5767	10917	17326	27849	44987	68209	74979
40"	1000	72	3584	7194	13117	20702	30991	47201	72344	102614
42"	1050	300	3509	7746	14660	23265	37395	60411	91594	100686
48"	1200	390	4597	10146	19195	26221	43873	79092	119966	131962

## Valve Pressure Drop Curve Table

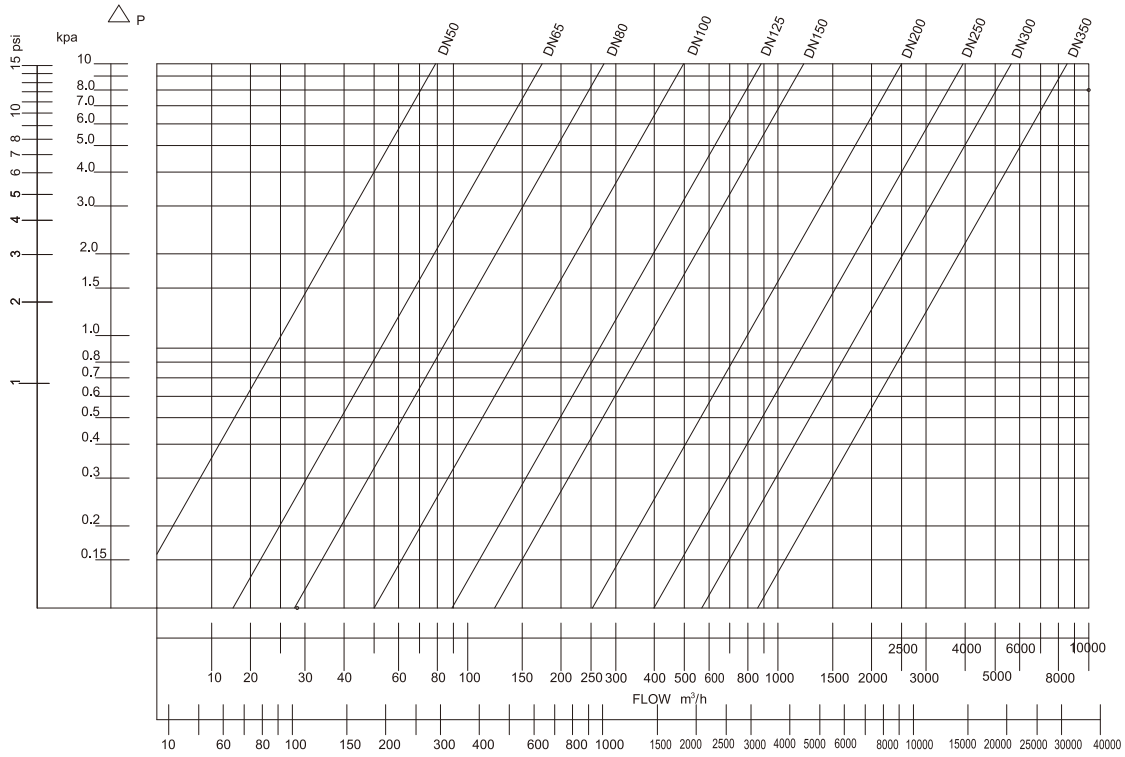

FLOW GALLON/MIN (m<sup>3</sup>/h)

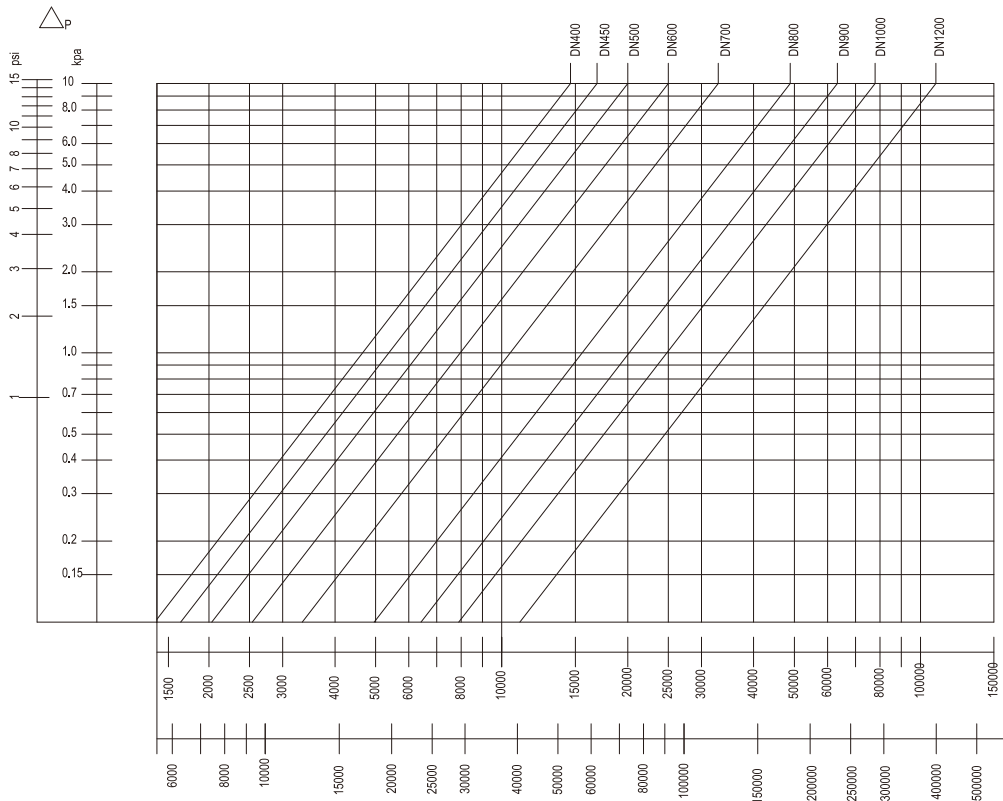

FLOW (m<sup>3</sup>/h)

## Lug Type with Pin (Series 300)

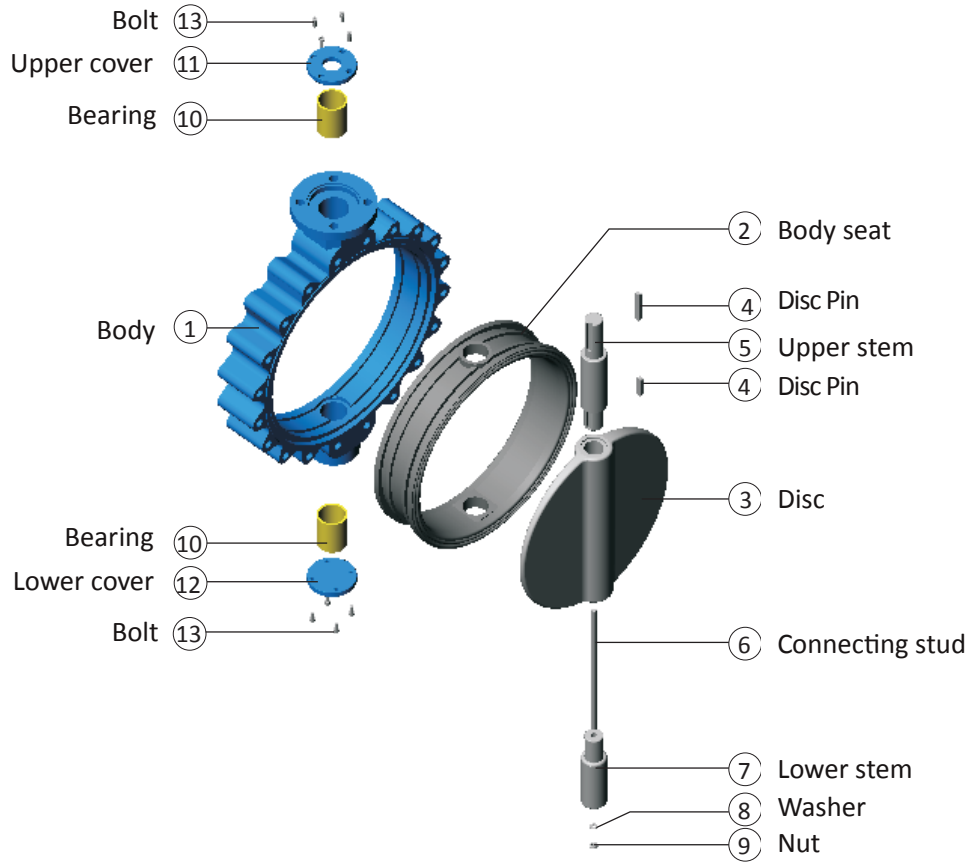

DN40-DN1200  
(1.5" - 48")

### Parts List & Materials

PARTS NAME	MATERIAL	SPECIFICATIONS (ASTM)
Body	Cast Iron Ductile Iron Carbon Steel Stainless Steel	ASTM A126B ASTM A536 A216 WCB A351 CF8M A351 CF8
Disc	Plated Ductile Iron Aluminum Bronze Stainless Steel Carbon Steel	ASTM A536 B148-954 A351 CF8M A351 CF8
Stem	Stainless Steel Carbon Steel	A276-410 A276-304 A276-316 A276-316L A216 WCB
Seat	NBR EPDM NEOPRENE VITON Natural Rubber PTFE	
PIN	Stainless Steel	A182 F6A A182 F304 A182 F316

## Lug Type with Pin (Series 300)

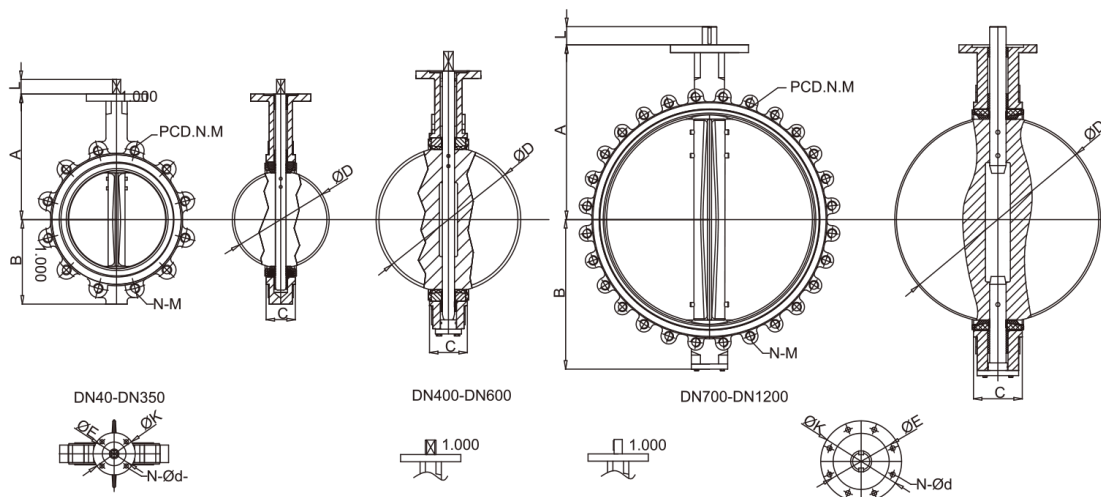

### Standard Specifications

Design Standard	: BS 5155, API 609, EN 593
Test Standard	: DIN 3230 Part3, API 598, EN 12266-1
Face-to-Face Standard	: DIN 3202 K1, API 609, EN558-1, ISO 5752
Flange Connection	: DIN 2501 PN10/16, BS 4505 PN10/16, ASME B16.1 125LB/150LB, JISB 2220 10K & so on.
Working Pressure	: 10 bar / 16 bar / Class 150
Medium	: Water, Sewage, Oil, Gas, Food and so on.

Size		A	B	C	d0	PCD	N-Q	ØK	ØE	N-ØP	B1xB2	J	L	ISO 5211
inch	mm													
1 1/2"	DN40	120	70	33	12.6	110	4-M16	65	50	4-7	9x9	-	26	F05
2"	DN50	161	80	43	12.6	125	4-M16	90	70	4-10	11x11	-	26	F07
2 1/2"	DN65	175	89	46	12.6	145	4-M16	90	70	4-10	11x11	-	30	F07
3"	DN80	181	95	46	12.6	160	8-M16	90	70	4-10	11x11	-	30	F07
4"	DN100	200	114	52	15.77	180	8-M16	90	70	4-10	11x11	-	30	F07
5"	DN125	213	127	56	18.92	210	8-M16	90	70	4-10	14x14	-	30	F07
6"	DN150	226	139	56	18.92	240	8-M20	90	70	4-10	14x14	-	40	F07
8"	DN200	260	175	60	22.1	295	8-M20	125	102	4-12	17x17	-	40	F10
10"	DN250	292	203	68	28.45	350	12-M20	125	102	4-12	22x22	-	40	F10
12"	DN300	337	242	78	31.6	400	12-M20	125	102	4-12	22x22	-	40	F10
14"	DN350	368	267	78	31.6	460	16-M20	125	102	4-12	22x22	-	40	F10
16"	DN400	400	309	102	33.15	515	16-M24	175	140	4-18	27x27	-	50	F14
18"	DN450	422	328	114	37.95	565	20-M24	175	140	4-18	27x27	-	70	F14
20"	DN500	480	361	127	41.12	620	20-M24	175	140	4-18	36x36	-	80	F14
24"	DN600	562	459	154	50.62	725	20-M27	210	165	4-23	36x36	-	80	F16
28"	DN700	624	520	165	63.35	840	24-M27	300	254	8-18	-	2-18	85	F25
32"	DN800	672	591	190	63.35	950	24-M30	300	254	8-18	-	2-18	95	F25
36"	DN900	720	656	203	74.7	1050	28-M33	300	254	8-18	-	2-20	118	F25
40"	DN1000	800	721	216	84.7	1160	28M-33	300	254	8-18	-	2-22	118	F25
48"	DN1200	941	864	276	104.7	1380	32-M26	350	298	8-22	-	2-28	154	F30

#### NOTE:

\*The shaft end can be double D and key connection. From DN700 and above, the shaft end is double key type.

\*The flange connection of the above table can be DIN2501 PN16, ASME B16.47-A 125/150LB, BS4504 PN10/PN16, JIS B2220 10K & so on.

① When working pressure is PN16, the diameter of the stems are different from PN10. (from DN400-DN600)

② DN400's valve face to face can be 85.7mm & 102mm. DN450's valve face to face can be 104mm & 114mm



## Lug Type without Pin (Series 400)

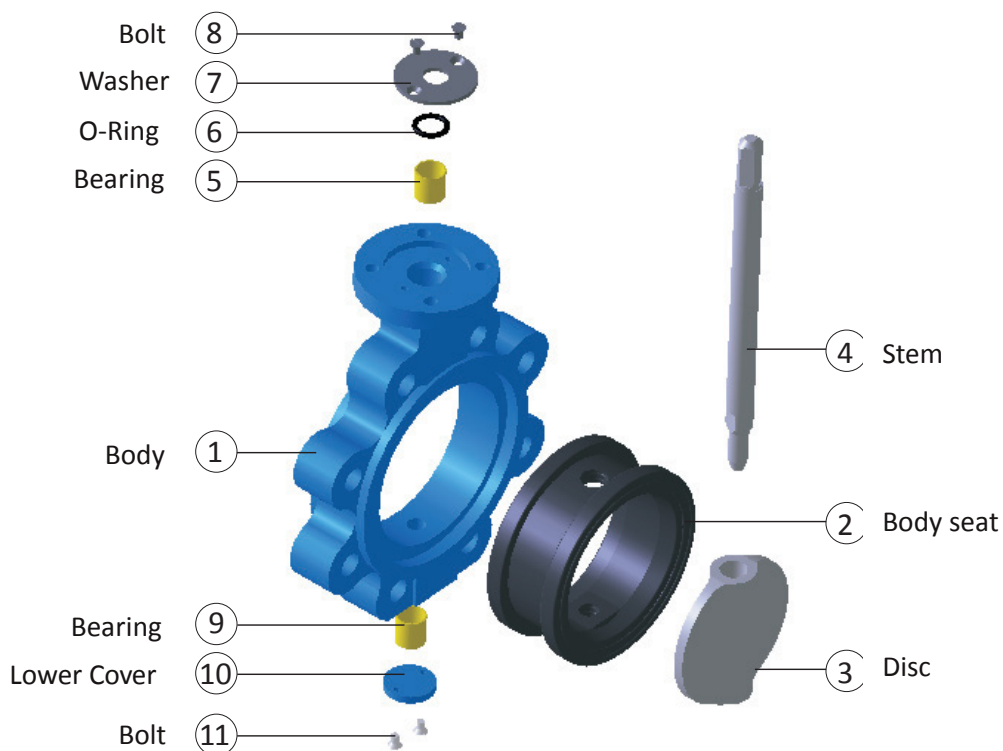

DN40-DN1200  
(1.5" - 48")

### Parts List & Materials

PARTS NAME	MATERIAL	SPECIFICATIONS (ASTM)
Body	Cast Iron Ductile Iron Carbon Steel Stainless Steel	ASTM A126B ASTM A536 A216 WCB A351 CF8M A351 CF8
Disc	Plated Ductile Iron Aluminum Bronze Stainless Steel Carbon Steel	ASTM A536 B148-954 A351 CF8M A351 CF8
Stem	Stainless Steel Carbon Steel	A276-410 A276-304 A276-316 A276-316L A216 WCB
Seat	NBR EPDM NEOPRENE VITON Natural Rubber PTFE	



## Lug Type without Pin (Series 400)

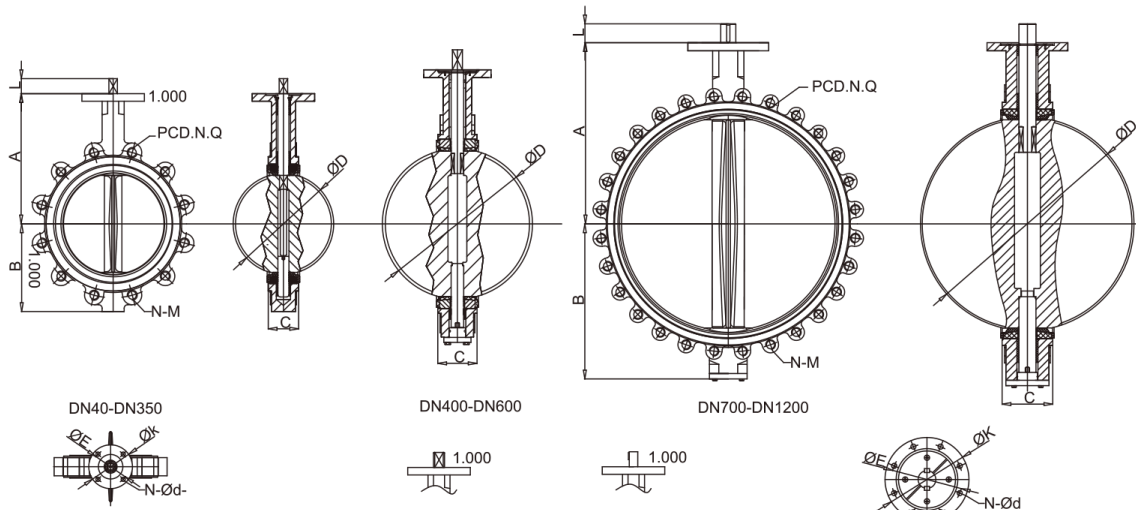

### Standard Specifications

Design Standard	: BS 5155, API 609, EN 593
Test Standard	: DIN 3230 Part3, API 598, EN 12266-1
Face-to-Face Standard	: DIN 3202 K1, API 609, EN558-1, ISO 5752
Flange Connection	: DIN 2501 PN10/16, BS 4505 PN10/16, ASME B16.1 125LB/150LB, JISB 2220 10K & so on.
Working Pressure	: 10 bar / 16 bar / Class 150
Medium	: Water, Sewage, Oil, Gas, Food and so on.

Size		A	B	C	d0	PCD	N-Q	ØK	ØE	N-ØP	B1xB2	J	L	ISO 5211
inch	mm													
1 1/2"	DN40	120	70	33	12.6	110	4-M16	65	50	4-7	9x9	-	26	F05
2"	DN50	161	80	43	12.6	125	4-M16	90	70	4-10	11x11	-	26	F07
2 1/2"	DN65	175	89	46	12.6	145	4-M16	90	70	4-10	11x11	-	30	F07
3"	DN80	181	95	46	12.6	160	8-M16	90	70	4-10	11x11	-	30	F07
4"	DN100	200	114	52	15.77	180	8-M16	90	70	4-10	11x11	-	30	F07
5"	DN125	213	127	56	18.92	210	8-M16	90	70	4-10	14x14	-	30	F07
6"	DN150	226	139	56	18.92	240	8-M20	90	70	4-10	14x14	-	40	F07
8"	DN200	260	175	60	22.1	295	8-M20	125	102	4-12	17x17	-	40	F10
10"	DN250	292	203	68	28.45	350	12-M20	125	102	4-12	22x22	-	40	F10
12"	DN300	337	242	78	31.6	400	12-M20	125	102	4-12	22x22	-	40	F10
14"	DN350	368	267	78	31.6	460	16-M20	125	102	4-12	22x22	-	40	F10
16"	DN400	400	309	102	33.15	515	16-M24	175	140	4-18	27x27	-	50	F14
18"	DN450	422	328	114	37.95	565	20-M24	175	140	4-18	27x27	-	70	F14
20"	DN500	480	361	127	41.12	620	20-M24	175	140	4-18	36x36	-	80	F14
24"	DN600	562	459	154	50.62	725	20-M27	210	165	4-23	36x36	-	80	F16
28"	DN700	624	520	165	63.35	840	24-M27	300	254	8-18	-	2-18	85	F25
32"	DN800	672	591	190	63.35	950	24-M30	300	254	8-18	-	2-18	95	F25
36"	DN900	720	656	203	74.7	1050	28-M33	300	254	8-18	-	2-20	118	F25
40"	DN1000	800	721	216	84.7	1160	28M-33	300	254	8-18	-	2-22	118	F25
48"	DN1200	941	864	276	104.7	1380	32-M26	350	298	8-22	-	2-28	154	F30

#### NOTE:

\*The shaft end can be double D and key connection. From DN700 and above, the shaft end is double key type.

\*The flange connection of the above table can be DIN2501 PN16, ASME B16.47-A 125/150LB, BS4504 PN10/PN16, JIS B2220 10K & so on.

① When working pressure is PN16, the diameter of the stems are different from PN10. (from DN400-DN600)

② DN400's valve face to face can be 85.7mm & 102mm. DN450's valve face to face can be 104mm & 114mm

## Torque Data

Total torque can be calculated as follows:

$$T_a = T_s + T_b + T_d$$

Where:

$T_s$  = Seat Torque  
 $T_b$  = Bearing Torque  
 $T_d$  = Dynamic Torque

$$T_b = Q_c * f_c * D_s / 2$$

Where:

$P$  = Normal Pressure  
 $f_c$  = Friction Coefficient  
 $D_s$  = Shaft Diameter

$$T_d = C_t * D^3 * \Delta P$$

Where:

$T_d$  = Dynamic Torque Coefficient  
 $D$  = Valve Normal Diameter  
 $\Delta P$  = Pressure Drop

$$T_s = Q_m * R / 1000$$

Where:

$Q_m$  = Friction of Sealing Face  
 $Q_c$  = Bearing Loading  
 $R$  = Radius Disc

The concentric butterfly valve's torque in relation to three factors:

### 1. Seat Torque

Friction of disc displace from the resilient seat.

### 2. Bearing Torque

Friction of force from the bushing surfaces and shaft.

### 3. Dynamic Torque

The force of flow through the valve faced by disc.

Dynamic torque is not a major concern in resilient seated butterfly valve unless the flow velocity exceeds 6 m/s. In such cases include dynamic torque valves while selecting an actuator.

$C_t$  Against Disc Angle Open

Angle Open	0°	10°	20°	30°	40°	50°	60°	70°	80°	90°
$C_t$	0	0.007	0.014	0.022	0.033	0.050	0.087	0.143	0.225	0

VALVE SIZE		Torque Value for Rubber Seat Butterfly Valve (N.m)					
		PN6 (85PSI)		PN10 (16PSI)		PN16 (250PSI)	
inch	mm	Dry	Wet	Dry	Wet	Dry	Wet
1.5"	40	11.5	8	18.5	9	22	11
2"	50	20.3	12.5	22.1	13.9	24.2	15.1
2.5"	65	26.1	13.8	29.2	15.4	32.7	17.2
3"	80	39.9	21	41.1	21.7	43.7	23.1
4"	100	60.5	34.9	67.8	37.1	72.8	39.8
5"	125	85.1	53.5	101	57.9	108	61.9
6"	150	149	84.5	165	93.9	174	102
8"	200	264	154	297	173	30	192
10"	250	423	249	486	286	549	323
12"	300	605	371	699	429	799	490
14"	350	699	466	825	550	970	625
16"	400	948	632	1133	755	1307	846
18"	450	1247	831	1518	1012	1788	1131
20"	500	1639	1093	2026	1350	2308	1431
24"	600	2519	1679	3166	2111	3711	2301
28"	700	4511	3008	4903	3269	6850	5670
30"	750	5222	3482	5677	3785	7916	6782
32"	800	5939	3762	6456	4304	9180	7840
36"	900	7363	4949	7879	5252	13786	10150
40"	1000	12539	8359	13377	8917	-	-
42"	1050	14300	9538	15291	10193	-	-
44"	1100	16301	10867	17390	11592	-	-
48"	1200	17585	11723	18816	12735	-	-
56"	1400	33800	28610	38600	31420	-	-
64"	1600	51380	43450	57910	49765	-	-
72"	1800	70381	59670	75820	63570	-	-
80"	2000	79560	62687	81703	69865	-	-
88"	2200	79860	69480	95760	78545	-	-

VALVE SIZE		Torque Value for Teflon Seat Butterfly Valve (N.m)			
		PN6 (85PSI)		PN16 (250PSI)	
inch	mm	Dry	Wet	Dry	Wet
1.5"	40	31.3	19.4	36.2	23
2"	50	39.1	24.3	45.2	28.2
2.5"	65	48.8	35	61	32.1
3"	80	74.6	39.4	81.8	43
4"	100	119.3	65.3	136	74.3
5"	125	175	100.6	202	116
6"	150	278	158	325	191
8"	200	494	287	617	358
10"	250	790	465	1026	603
12"	300	1132	694	1493	916
14"	350	1814	1153	1905	1269
16"	400	2398	1394	2518	1534
18"	450	3340	2047	3508	2252
20"	500	4122	2449	4329	2694
24"	600	7044	3882	7396	4270

VALVE SIZE		Torque Value for Double Eccentric Butterfly Valve (N.m)		
		PN6	PN10	PN16
inch	mm			
4"	100	55	70	240
5"	125	100	140	265
6"	150	121	175	340
8"	200	190	328	574
10"	250	290	545	847
12"	300	490	894	1358
14"	350	804	1269	1905
16"	400	1074	1534	2528
18"	450	1328	2252	3508
20"	500	1550	2694	4329
24"	600	3189	4270	7396
28"	700	3640	6425	9873
30"	750	3917	8680	11716
32"	800	5143	9022	13765
36"	900	6950	11877	19398
40"	1000	9187	15630	27626
48"	1200	8632	22688	33920
56"	1400	22887	27762	63639
64"	1600	26897	36978	93255
72"	1800	36730	56668	126914

## Lever & Gearbox Selection

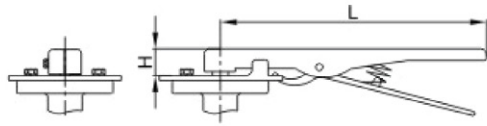

Type A Cast Iron Lever

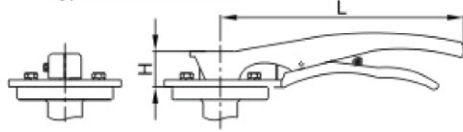

Type B Punched steel Lever

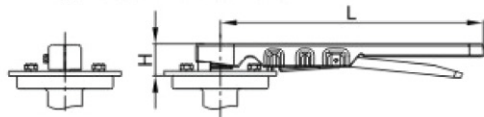

Type C Punched steel Lever

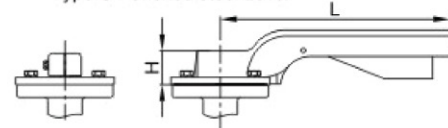

Type D Aluminum Alloy Lever



Type A Product photo



Type B Product photo



Type C Product photo



Type D Product photo

Size		ISO 5211 TOP FLANGE	TYPE A		TYPE B		TYPE C		TYPE D	
inch	mm		L	H	L	H	L	H	L	H
2"	50	F05	245	32	240	32	220	27	200	26
2 1/2"	65	F05	245	32	240	32	220	27	200	26
3"	80	F05	245	32	240	32	220	27	275	32
4"	100	F07	280	32	265	32	240	30	275	32
5"	125	F07	280	32	265	32	260	30	275	32
6"	150	F07	280	32	265	32	260	30	275	32
8"	200	F10	390	45	265	32	260	30	275	32
10"	250	F10	390	45	395	39	395	39	395	30
12"	300	F10	535	45	395	39	395	39	395	30

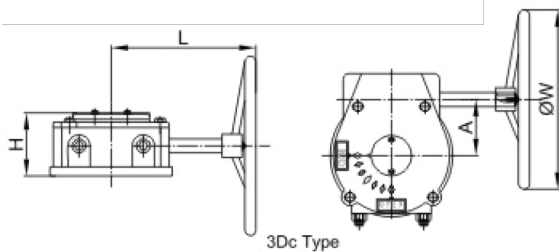

3Dc Type

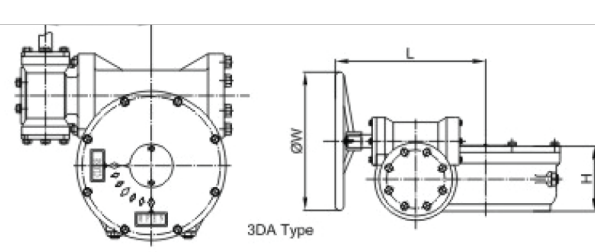

3DA Type

Size Range	TYPE	RATED OUTPUT (N.m)	MAXIMUM OUTPUT (N.m)	RATIO	A	L	H
2" - 6"	3Dc - 15	245	32	240	32	220	27
8" - 10"	3Dc - 50	245	32	240	32	220	27
12" - 14"	3Dc - 120	245	32	240	32	220	27
16" 20"	3DA - 30/250	280	32	265	32	240	30
24"	3DA - 30/400	280	32	265	32	260	30
28" 32"	3DA - 30/800	280	32	265	32	260	30
36" 44"	3DA - 120/1500	390	45	265	32	260	30
48"	3DA - 120/2500	390	45	395	39	395	39

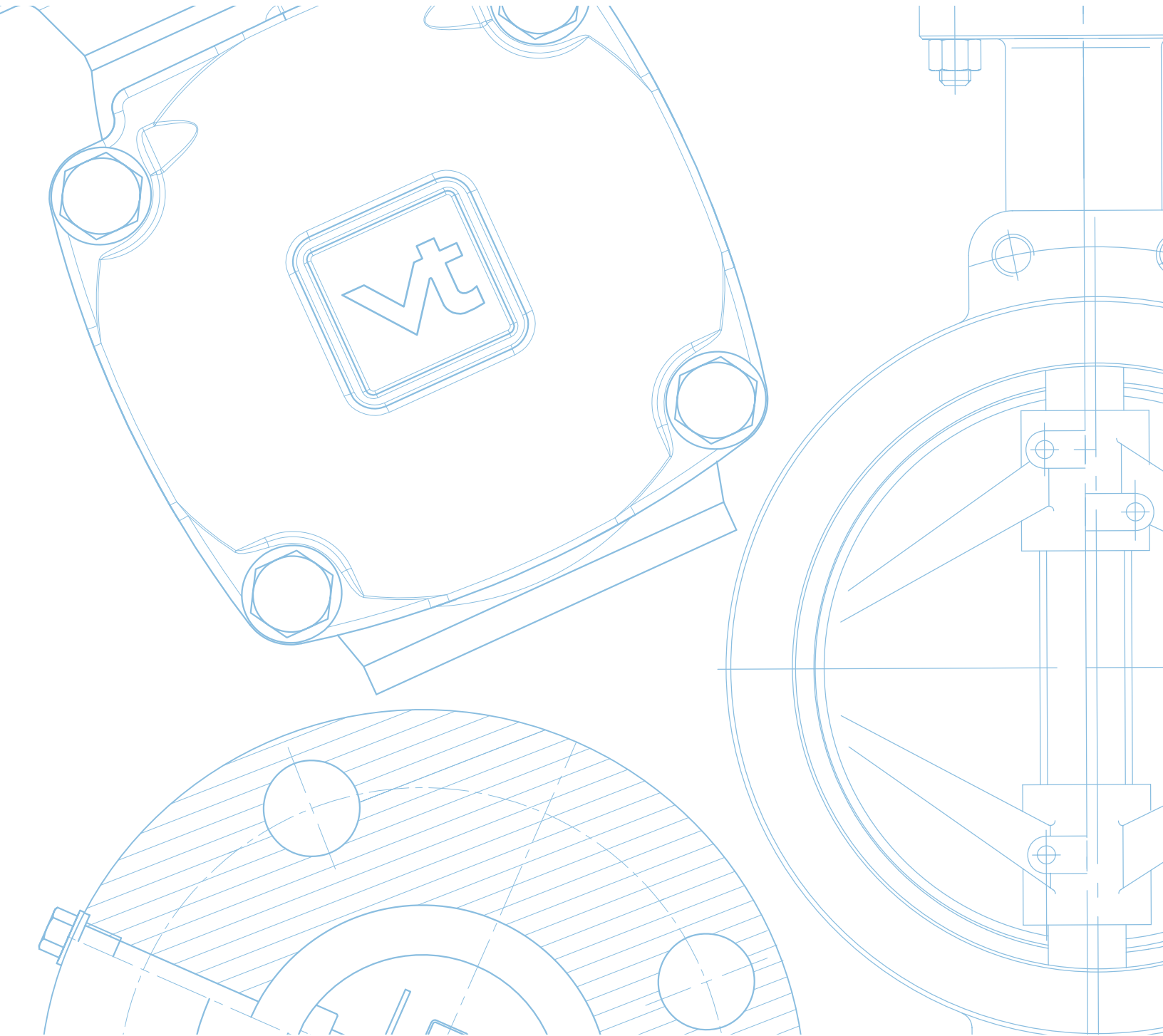

**VAHN-TECH International Inc.**

2608-88, Bluejays Way, Toronto, Ontario, M5V 0L7, Canada

Tel.: +1 416 342 0001 E-mail: [info@vahn-tech.com](mailto:info@vahn-tech.com)

[www.vahn-tech.com](http://www.vahn-tech.com)