



FLOATING SEAT TRIPLE OFFSET BUTTERFLY VALVES



Intertek



VAHN-TECH International Inc., headquartered in Toronto, Canada is a unique company within the Flow Control Industry.

- ✳ 'vt' brand = high quality certified products (API, NSF, CSA, WRAS etc.)
- ✳ Valves, Actuators and Accessories – all 'vt' branded
- ✳ Width and Depth of Product Offerings
- ✳ Flexibility to customize products to customer needs
- ✳ Specialized user-friendly products including large sizes
- ✳ Quick Response
- ✳ Reduced Delivery times
- ✳ Efficient after sales service
- ✳ Competitive Pricing

VAHN-TECH International Inc. is a customer focused organization based on “Value-Add” and “Quality Service” principles. Achieving long term partnership with our customers and being their supplier of choice is our prime mission.

We develop, manufacture and market VAHN-TECH (vt) branded Valves, Actuators, Automatic Control Valves and Accessories for variety of Industrial Applications. Our product range includes:



Oil and Gas



Water and Sewage,
Desalination



Chemicals



Paper and Pulp



Irrigation



Power Plants



Various
Industrial Applications

We can supply all types of valves with following materials of construction like:

Ductile Iron, Cast Iron, Carbon Steel, Stainless Steel – SS304, SS304L, SS316, SS316L, Duplex Stainless Steel, Super Duplex, Alloy, Monel and Inconel with variety of seating and stem configurations.



Table of Contents

FLOATING SEAT TRIPLE OFFSET BUTTERFLY VALVES

Design & Features	1
Design Standards	
Principle of Operation	
Design Features	
Seat Ring Design	
End Connections	
Materials of Construction	4
Dimensions	6
Wafer/Lug Type	
Flanged Ends	
Butt-Weld Ends	
Technical Information	9
Flow Characteristics	
Torque Values	
Pressure & Temperature Ratings	
Product Selection	11

1. Design Standards

Applicable Standards	
Design Standard:	API 609
End Connection:	ASME B16.5 / ASME B16.47 / ASME B16.25
Face-to-Face:	API 609 / ASME B16.10
Test & Inspection:	API 598
Fire-Safe:	API 607
Low Fugitive Emission:	ISO 15848-2015
NACE:	MR 0715

2. Principle of Operation

The triple-offset geometry ensures that the body and disc come into contact only at the final shut-off position. This eliminates wear and tear due to friction between mating surfaces during operation, reduces operating torque and enhances product life.

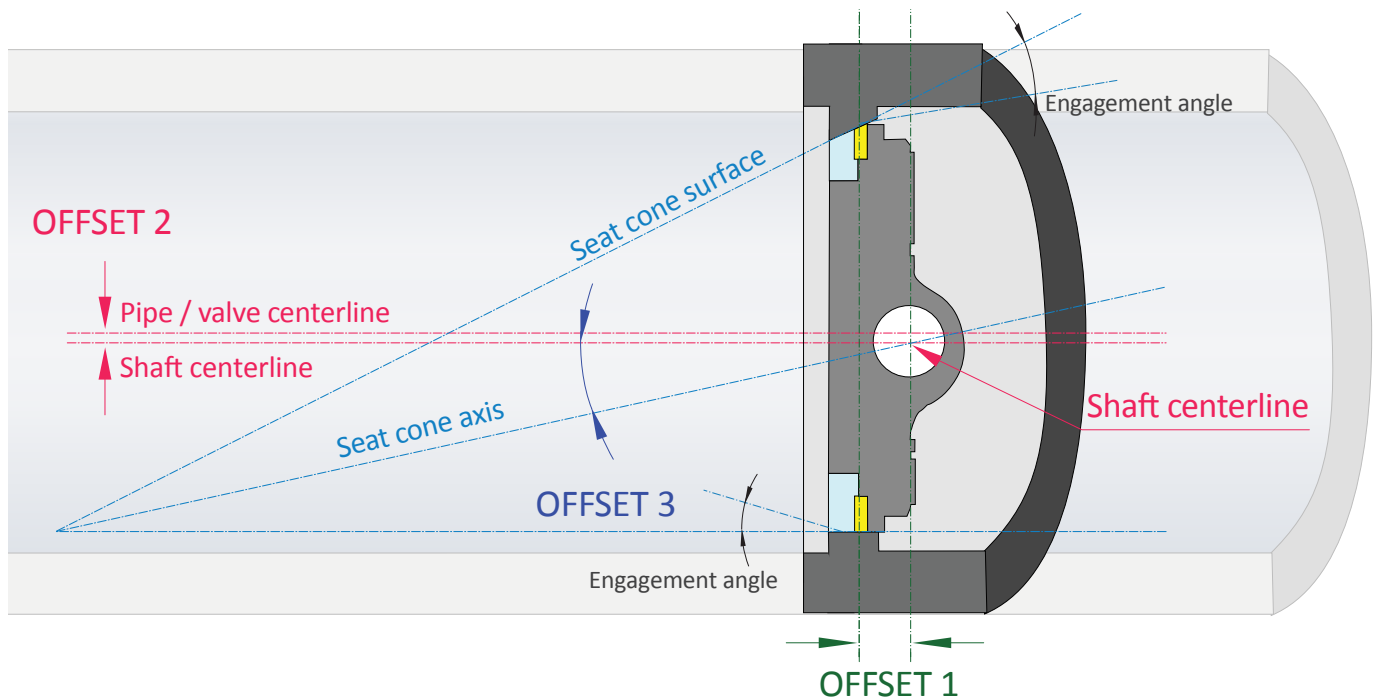

Offset 1

The shaft of the valve is behind the disc, providing a continuous sealing area all around the disc.

Offset 2

The shaft is offset from the pipe centerline allowing displacement of the sealing from the seat during the 90° opening.

Offset 3

Axis of conical sealing is inclined to the centreline of valve eliminating friction during open and close operations thereby achieving uniform sealing around complete seat.

3. Design Features

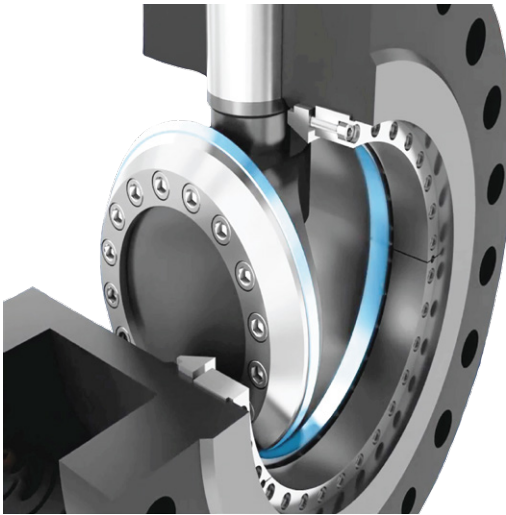

- ✦ Fully bi-directional design with floating seat on the body
- ✦ Anti-blowout proof stem for high dependability, fully compliant with API609
- ✦ Inherently fire-safe for both composite and metal seats
- ✦ Double stem structure: Lower flow resistance & reduced energy consumption
- ✦ High temperature resistance up to +850°C
- ✦ Cryogenic application to -196°C
- ✦ Replaceable Disc & Body Seal on site
- ✦ Extended service lifetime
- ✦ Design available for high pressure - up to Class 2500

Pressure Testing and Leakage Rate

Shell Test Pressure	:	Nominal Pressure *1.5
Positive Test Pressure	:	Nominal Pressure*1.1
Reverse Test Pressure	:	Nominal Pressure*1.0
Positive and Reverse Air Test	:	0.6 MPa
Zero Leakage Seat Tightness	:	API 598 / Leakage Class VI

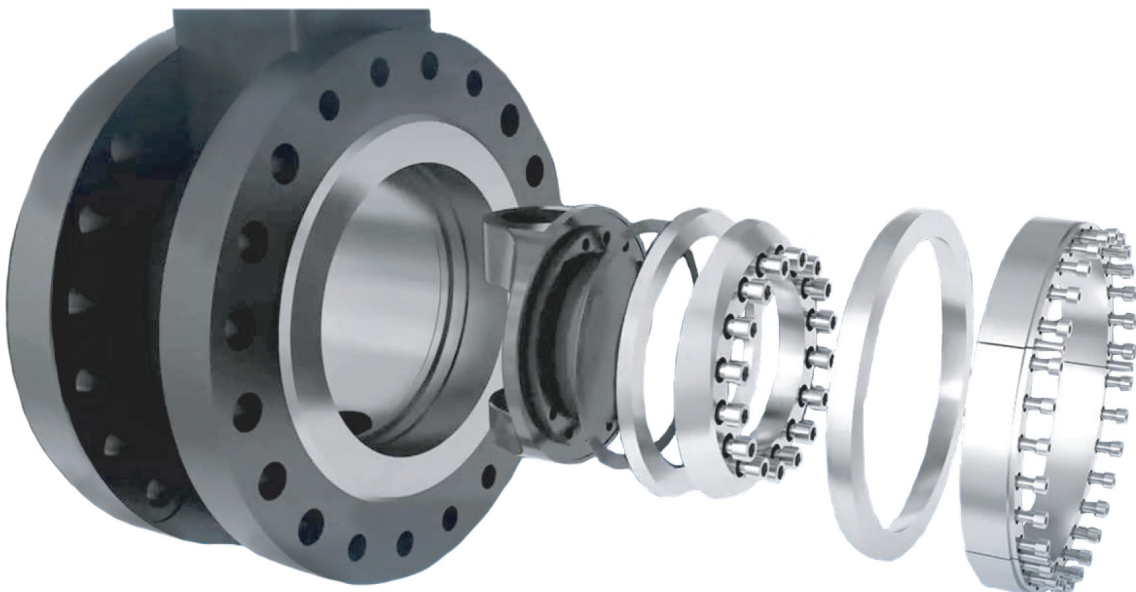

4. Seat Ring Design Features

Seat Rings (or Seal Rings) are replaceable – on site – on both the Body and the Disc. Seat rings are fixed with bolts to ensure enhanced replaceability.



Solid Seal Ring

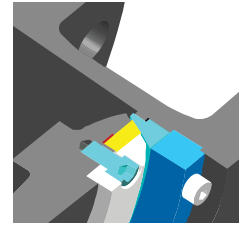

Metal to Metal Seal Ring

Disc Seat Rings are available with Metal-to-Metal sealing and Multi-layer sealing. Multi-layer sealing is made of composite layers of Stainless Steel and Non-metal material. Non-metal material can be Flexible Graphite, PTFE or other material depending on the media and operating conditions.



Multi-layer Seal Ring

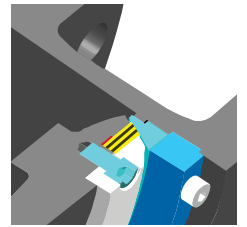

Multi-layer Seal Ring

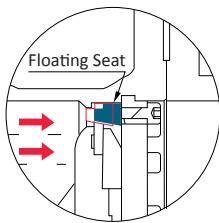

Main Flow Direction

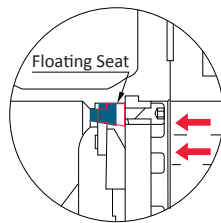

Opposite Flow Direction

Floating Seat for Bi-directional Sealing: The body seat can move between the body and the seat retainer to allow 100% leakage tightness in case of backflow.

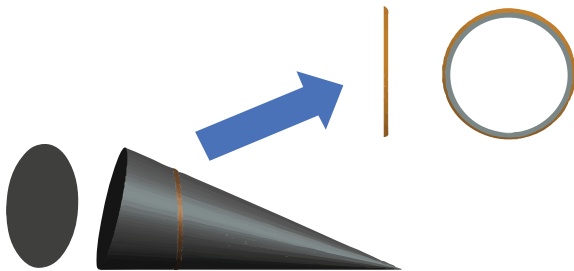

Disc Seat Ring Machining: The seat is specially designed with elliptic shape instead of round shape. The upgraded seal can better control the expansion and contraction deformation during changing temperature conditions, improving the sealing performance across the whole operating range of the valves.

Cambered Sealing Surface: The Seal Rings are machined with a rounded sealing surface to improve the contact between the 2 seal rings. This design also allows for line sealing making the Floating Seat Butterfly Valves in the configuration suitable for media with impurities such as:

1. Mucus, Granular Medium
2. Solid Powder
3. Crystallized Medium
4. Liquid Medium with High Temperature Curing
5. Fiber Slurry
6. High Temperature Melts

5. Available End Connections



Wafer



Lug



Butt-Weld



Double Flange

6. Material of Construction

6.1 Butt-Weld Configuration

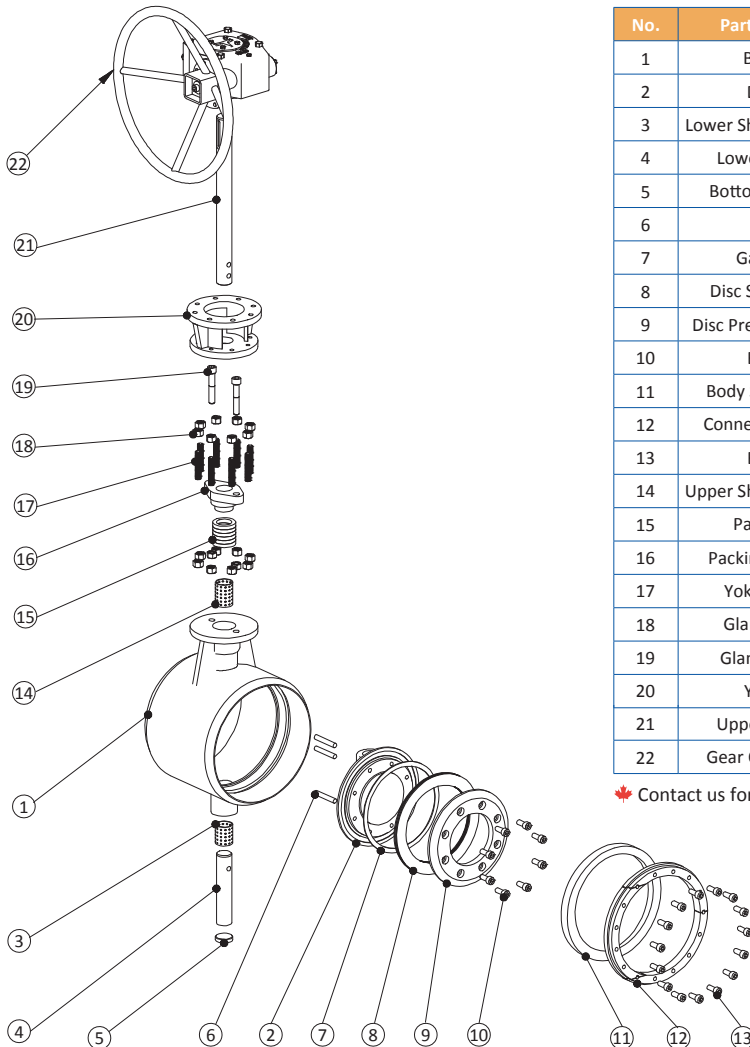

No.	Part Name	Carbon Steel Configuration	Stainless Steel Configuration
1	Body	ASTM A105	ASTM A182 F316
2	Disc	ASTM A216 WCB	ASTM A351 CF8M
3	Lower Shaft Bearing	SS316	SS316
4	Lower Shaft	SS420	17-4PH
5	Bottom Cover	ASTM A105	ASTM A182 F316
6	Pin	ASTM A182 F316	ASTM A182 F316
7	Gasket	Graphite	Graphite
8	Disc Seal Ring	SS420	17-4PH
9	Disc Pressure Ring	ASTM A193 B7	SS304
10	Bolt	ASTM A105	ASTM A182 F316
11	Body Seal Ring	ASTM A182 F6a	ASTM A182 F316
12	Connector Ring	ASTM A193 B7	SS304
13	Bolt	ASTM A105	ASTM A182 F316
14	Upper Shaft Bearing	SS316	SS316
15	Packing	Graphite	Graphite
16	Packing Gland	ASTM A216 WCB	ASTM A216 WCB
17	Yoke Stud	ASTM A193 B7	SS304
18	Gland Nut	ASTM A194 2H	SS304
19	Gland Stud	ASTM A193 B7	SS304
20	Yoke	ASTM A216 WCB	ASTM A216 WCB
21	Upper Shaft	SS420	17-4PH
22	Gear Operator	Assembly	Assembly

🔴 Contact us for other material options.

6.2 Double Flange, Lug and Wafer Configuration

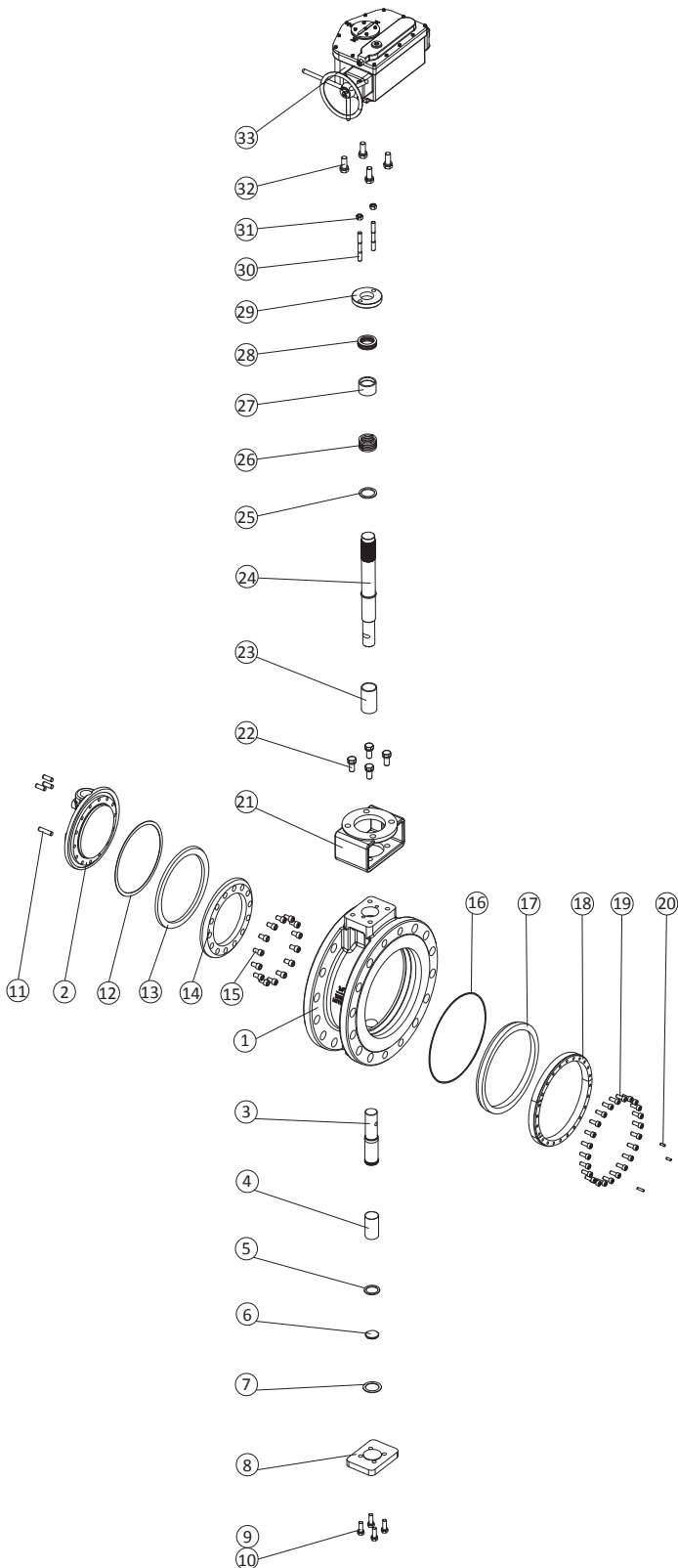

No.	Part Name	Carbon Steel Configuration	Stainless Steel Configuration
1	Body	ASTM A216 WCB	ASTM A351 CF8M
2	Disc	ASTM A216 WCB	ASTM A351 CF8M
3	Shaft	ASTM A276 420	17-4PH
4	Sleeve	D-2+Ni	SS316
5	Locking Ring	D-2	SS316
6	Flange	ASTM A29M 1025	SS316
7	Gasket	SS316+Graphite	SS316+Graphite
8	Flange	ASTM A29M 1025	SS316
9	Bolt	ASTM A193 B7	SS304
10	Washer	ASTM A29M 5140	SS304
11	Pin	SS304	17-4PH
12	Gasket	SS316+Graphite	SS316+Graphite
13	Disc Seal Ring	ASTM A182 F316L	ASTM A182 F316L
14	Disc Pressure Ring	ASTM A276 420	SS316
15	Capscrew	SS304	SS316
16	Gasket	SS316+Graphite	SS316+Graphite
17	Body Seal Ring	ASTM A276 420	SS316
18	Connector Ring	ASTM A276 420	SS316
19	Capscrew	SS304	SS316
20	Grub Screw	SS304	SS316
21	Yoke	ASTM A216 WCB	ASTM A216 WCB
22	Bolt	ASTM A193 B7	SS304
23	Sleeve	D-2+Ni	SS316
24	Shaft	ASTM A276 420	17-4PH
25	Packing Ring	D-2	SS316
26	Packing	Graphite	Graphite
27	Packing Gland	ASTM A29M 1025	SS304
28	Butterfly Spring	Spring Steel	Spring Steel
29	Packing Plate	ASTM A29M 1025	SS304
30	Gland Stud	ASTM A193 B7	SS304
31	Gland Nut	ASTM A194 2H	SS304
32	Bolt	ASTM A193 B7	SS304
33	Gearbox	Assembly	Assembly

🇨🇦 Contact us for other material options.

7. Dimensions (mm)

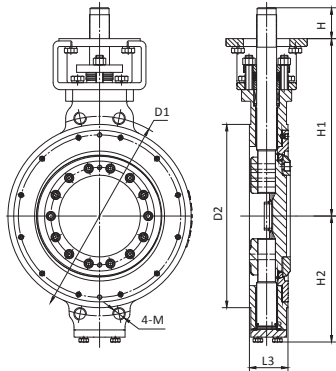

Wafer Type

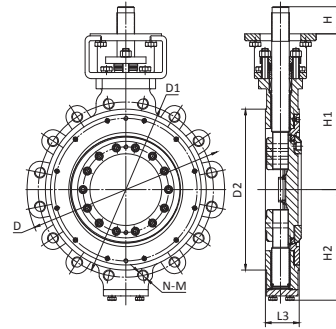

Lug Type

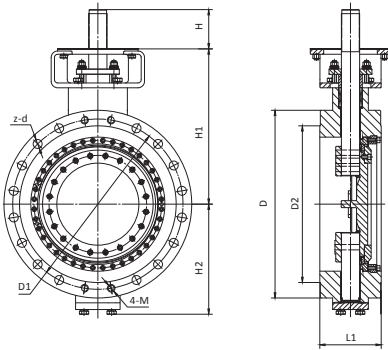

Double Flanged Type

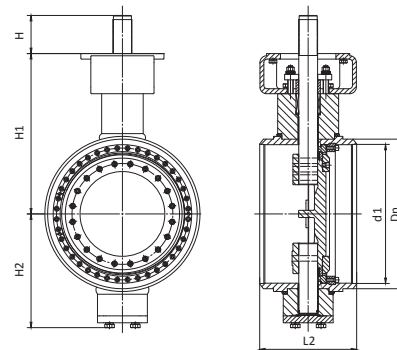

Butt Weld Type

Class 150

NPS	DN	L1	L2	L3	D	D1	D2	z-d	M	N	d1	Dn	H1	H2	H
2"	50	108	150	43	150	120.7	92.1	4- \emptyset 19	5/8-11 UNC 2B	4	52.5	60.3	193	94	20
3"	80	114	180	48	190	152.4	127	4- \emptyset 19	5/8-11 UNC 2B	4	77.9	88.9	221	118	25
4"	100	127	190	54	230	190.5	157.2	4- \emptyset 19	5/8-11 UNC 2B	8	102.3	114.3	243	130	30
5"	125	140	200	56	255	215.9	185.7	4- \emptyset 22	3/4-10 UNC 2B	8	128.2	139.7	261	153	35
6"	150	140	210	57	280	241.3	215.9	4- \emptyset 22	3/4-10 UNC 2B	8	154.1	168.3	273	165	40
8"	200	152	230	64	345	98.5	260.9	4- \emptyset 22	3/4-10 UNC 2B	8	202.7	219.1	309	198	45
10"	250	165	250	71	405	362	323.8	8- \emptyset 26	7/8-9 UNC 2B	12	254.5	273	337	235	50
12"	300	178	270	81	485	431.8	381	8- \emptyset 26	7/8-9 UNC 2B	12	304.8	323.9	382.5	274.5	67
14"	350	190	290	92	535	476.3	412.8	8- \emptyset 29	1-8 UNC 2B	12	336.6	355.6	435	314	81
16"	400	216	310	102	595	539.8	469.9	12- \emptyset 29	1-8 UNC 2B	16	387.4	406.4	457	344	87
18"	450	222	330	114	635	577.9	533.4	12- \emptyset 32	1-1/8-8 UN-2B	16	434.9	457	510	369	98
20"	500	229	350	127	700	635	584.2	16- \emptyset 32	1-1/8-8 UN-2B	20	482.6	508	579	410.5	105
24"	600	267	390	154	815	749.3	692.2	16- \emptyset 35	1-1/4-8 UN-2B	20	581.1	610	653	472.5	117
28"	700	292	430	229	925	863.6	800	24- \emptyset 35	1-1/4-8 UN-2B	28	672.7	711.2	671	529.5	117
32"	800	318	470	241	1060	977.9	914	24- \emptyset 42	1-1/2-8 UN-2B	28	770.7	812.8	800	648	120
36"	900	330	510	241	1170	1085.8	1022	28- \emptyset 42	1-1/2-8 UN-2B	32	869.3	914.4	862	708.2	128
40"	1000	410	550	300	1290	1200.2	1124	32- \emptyset 42	1-1/2-8 UN-2B	36	967.3	1016	955	766.2	170
48"	1200	470	630	360	1510	1510	1359	40- \emptyset 42	1-1/2-8 UN-2B	44	1164	1219.2	1088	884	182

Class 300

NPS	DN	L1	L2	L3	D	D1	D2	z-d	M	N	d1	Dn	H1	H2	H
2"	50	150	150	43	165	127	92.1	4-Ø19	5/8-11 UNC 2B	8	52.5	60.3	135	120	30
3"	80	180	180	48	210	168.3	127	4-Ø22	3/4-10 UNC 2B	8	77.9	88.9	159	145	34
4"	100	190	190	54	255	200	157.2	4-Ø22	3/4-10 UNC 2B	8	102.3	114.3	194	165	34
5"	125	200	200	56	280	235	185.7	4-Ø22	3/4-10 UNC 2B	8	128.2	139.7	269	200	64
6"	150	210	210	59	320	269.9	215.9	8-Ø22	3/4-10 UNC 2B	12	154.1	168.3	269	200	64
8"	200	230	230	73	380	330.2	269.9	8-Ø26	7/8-9 UNC 2B	12	202.7	219.1	285	235	79
10"	250	250	250	83	445	387.4	323.8	12-Ø29	1-8 UNC 2B	16	254.5	273	325	275	79
12"	300	270	270	92	520	450.8	381	12-Ø32	1-1/8-8 UN-2B	16	304.8	323.9	387	315	79
14"	350	290	290	117	585	514.4	412.8	16-Ø32	1-1/8-8 UN-2B	20	336.6	355.6	410	350	79
16"	400	310	310	133	650	571.5	469.9	16-Ø35	1-1/4-8 UN-2B	20	387.4	406.4	465	385	109
18"	450	330	330	149	710	628.6	533.4	20-Ø35	1-1/4-8 UN-2B	24	434.9	457	528	415	109
20"	500	350	350	159	775	688.8	584.2	20-Ø35	1-1/4-8 UN-2B	24	482.6	508	561	450	129
24"	600	390	390	181	915	812.8	692.2	20-Ø42	1-1/2-8 UN-2B	24	581.1	610	636	530	129
28"	700	430	430	229	1035	939.8	800	24-Ø45	1-5/8-8 UN-2B	28	672.7	711.2	800	590	199
32"	800	470	470	241	1150	1054.1	914	24-Ø52	1-7/8-8 UN-2B	28	770.7	812.8	860	720	199
36"	900	510	510	241	1270	1168.4	1022	28-Ø54	2-8 UN-2B	32	869.3	914.4	940	780	199
40"	1000	550	550	300	1240	1155.7	1086	28-Ø45	1-5/8-8 UN-2B	32	967.3	1016	910	750	199
48"	1200	630	630	360	1465	1371.6	1302	28-Ø52	1-7/8-8 UN-2B	32	1164	1219.2	1000	850	249

Class 600

NPS	DN	L1	L2	L3	D	D1	D2	z-d	M	N	d1	Dn	H1	H2	H
2"	50	150	150	43	165	127	92.1	4-Ø19	5/8-11 UNC 2B	8	52.5	60.3	175	125	40
3"	80	180	180	54	210	168.3	127	4-Ø22	3/4-10 UNC 2B	8	77.9	88.9	202	145	44
4"	100	190	190	64	275	215.9	157.2	4-Ø26	7/8-9 UNC 2B	8	102.3	114.3	208	180	44
5"	125	200	200	70	330	266.7	185.7	4-Ø29	1-8 UNC 2B	8	128.2	139.7	235	210	79
6"	150	210	210	78	355	92.1	215.9	8-Ø29	1-8 UNC 2B	12	154.1	168.3	302	225	79
8"	200	230	230	102	420	349.2	269.9	8-Ø32	1-1/8-8 UN-2B	12	198.5	219.1	315	265	79
10"	250	250	250	117	510	431.8	323.8	12-Ø35	1-1/4-8 UN-2B	16	247.7	273	376	310	79
12"	300	270	270	140	560	489	381	16-Ø35	1-1/4-8 UN-2B	20	295.3	323.9	442	340	109
14"	350	290	290	155	605	527	412.8	16-Ø39	1-3/8-8 UN-2B	20	325.4	355.6	457	365	109
16"	400	310	310	178	685	603.2	469.9	16-Ø42	1-1/2-8 UN-2B	20	363.5	406.4	561	410	129
18"	450	330	330	200	745	654	533.4	16-Ø45	1-5/8-8 UN-2B	20	409.5	457	610	450	129
20"	500	350	350	216	815	723.9	584.2	20-Ø45	1-5/8-8 UN-2B	24	455.6	508	645	485	129
24"	600	390	390	232	940	838.2	692.2	20-Ø52	1-7/8-8 UN-2B	24	547.7	610	730	555	178

Class 900

NPS	DN	L1	L2	L3	D	D1	D2	z-d	M	N	d1	Dn	H1	H2	H
4"	100	235	235	80	290	235	157.2	4-Ø32	1-1/8-8 UN-2B	8	77.9	88.9	240	181	64
6"	150	250	250	104	380	317.5	215.9	8-Ø32	1-1/8-8 UN-2B	12	102.3	114.3	315	238	79
8"	200	310	310	112	470	393.7	269.9	8-Ø39	1-3/8-8 UN-2B	12	128.2	139.7	360	281	79
10"	250	350	350	135	545	469.9	323.8	12-Ø39	1-3/8-8 UN-2B	16	154.1	168.3	412	358	109
12"	300	380	380	170	610	533.4	381	16-Ø39	1-3/8-8 UN-2B	20	198.5	219.1	475	383	109
14"	350	400	400	173	640	558.8	412.8	16-Ø42	1-1/2-8 UN-2B	20	247.7	273	512	419	128
16"	400	430	430	210	705	616	469.9	16-Ø45	1-5/8-8 UN-2B	20	295.3	323.9	610	455	129
18"	450	460	460	228	785	685.8	533.4	16-Ø52	1-7/8-8 UN-2B	20	325.4	355.9	660	503	178
20"	500	490	490	250	855	749.3	584.2	16-Ø54	2-8 UN-2B	20	363.5	406.4	685	550	178
24"	600	530	530	275	1040	901.7	692.2	16-Ø57	2-1/2-6 UN-2B	20	409.5	457	790	656	199

Class 1500

NPS	DN	L1	L2	L3	D	D1	D2	z-d	M	N	d1	Dn	H1	H2	H
6"	150	290	290	160	395	317.5	215.9	8-Ø39	1-1/8-8 UN-2B	12	102.3	114.3	347	347	109
8"	200	330	330	180	485	393.7	269.9	8-Ø45	1-5/8-8 UN-2B	12	128.2	139.7	405	405	109
10"	250	390	390	200	585	482.6	323.8	8-Ø52	1-7/8-8 UN-2B	12	154.1	168.3	510	510	129
12"	300	430	430	230	675	571.5	381	12-Ø54	2-8 UN-2B	16	198.5	219.1	545	545	129
14"	350	470	470	250	750	635	412.8	12-Ø61	2-1/4-8 UN-2B	16	247.7	273	610	610	178
16"	400	510	510	265	825	704.8	469.9	12-Ø67	2-1/2-8 UN-2B	16	295.3	323.9	655	655	199
18"	450	550	550	300	915	774.7	533.4	12-Ø74	2-3/4-6 UN-2B	16	325.4	355.9	750	750	199
20"	500	630	630	340	985	831.8	584.2	12-Ø80	3-6 UN-2B	16	363.5	406.4	810	810	199
24"	600	710	710	400	1170	990.6	692.2	12-Ø94	3-1/2-6 UN-2B	16	409.5	457	950	950	249

VAHN-TECH International Inc. reserves the right to change the technical data without prior notice.

8. Technical Information

a. Flow Characteristics

Cv Values

Class 150

NPS	DN	5°	10°	15°	20°	25°	30°	35°	40°	45°	50°	55°	60°	65°	70°	75°	80°	85°	90°
3"	80	1	6	14	23	31	39	47	54	62	71	82	96	112	128	143	156	163	165
4"	100	2	12	26	42	57	72	85	98	113	130	150	176	205	234	262	285	299	302
6"	150	16	31	45	59	76	101	34	178	233	297	369	448	531	616	698	758	796	796
8"	200	30	57	82	108	140	185	246	327	427	544	676	821	974	1130	1280	1390	1460	1460
10"	250	52	99	142	187	242	320	426	566	739	942	1170	1420	1690	1960	2220	2410	2530	2530
12"	300	78	147	212	279	362	478	636	846	1100	1410	1750	2120	2520	2920	3310	3600	3780	3780
14"	350	106	201	289	380	493	651	866	1150	1500	1920	2380	2890	3430	3980	4510	4890	5140	5140
16"	400	165	313	451	594	769	1020	1350	1800	2350	2990	3720	4510	5350	6210	7040	7640	8020	8020
18"	450	217	413	594	782	1010	1340	1780	2370	3090	3940	4890	5940	7050	8180	9270	10100	10600	10600
20"	500	268	509	733	965	1250	1650	2200	2920	3820	4860	6040	7340	8710	10100	11400	12400	13000	13000
24"	600	386	734	1060	1390	1800	2380	3170	4210	5500	7000	8700	10600	12500	14500	16500	17900	18800	18800
28"	700	559	1060	1530	2010	2610	3450	4590	6100	7960	10100	12600	15300	18200	21100	23900	25900	27200	27200
30"	750	630	1200	1720	2270	2940	3880	5160	6870	8960	11400	14200	17200	20400	23700	28900	29200	30700	30700
32"	800	719	1370	1970	2590	3360	4440	5900	7840	10200	13000	16200	19700	23300	27100	30700	33300	35000	35000
36"	900	884	1680	2420	3180	4120	5450	7250	9630	12600	16000	19900	24200	28700	33300	37700	40900	43000	43000
40"	1000	1170	2220	3190	4210	5250	7210	9580	1200	16600	21200	26300	31900	37900	44000	49800	54100	56900	56900
42"	1050	1230	2340	3370	4440	5760	7610	10100	13400	17600	22400	27800	33700	40000	46500	52600	57100	60000	60000
48"	1200	1640	3120	4490	5920	7670	10100	13500	17900	23400	29800	37000	45000	53400	61900	70100	76100	80000	80000

Class 300

NPS	DN	5°	10°	15°	20°	25°	30°	35°	40°	45°	50°	55°	60°	65°	70°	75°	80°	85°	90°
3"	80	1	6	14	23	31	39	47	54	62	71	82	96	112	128	143	156	163	165
4"	100	2	12	26	42	57	72	85	98	113	130	150	176	205	234	262	285	299	302
6"	150	6	25	41	54	69	101	121	162	212	268	334	407	482	559	634	689	725	725
8"	200	11	45	74	98	126	185	222	298	389	492	613	746	884	1030	1160	1260	1330	1330
10"	250	19	82	135	178	229	320	402	540	705	891	1110	350	1600	1860	2110	2290	2310	2410
12"	300	29	122	202	266	342	478	601	807	1050	1330	1660	2020	2400	2780	3150	3420	3600	3600
14"	350	39	167	274	363	466	651	818	1100	1430	1810	2260	2750	3260	3780	4290	4660	4900	4900
16"	400	58	248	408	539	692	1020	1220	1630	2130	2690	3360	4090	4840	5610	6370	6920	7280	7280
18"	450	77	326	537	710	911	1340	1600	2150	2810	3550	4420	5380	6380	7400	8390	9110	9590	9590
20"	500	95	403	663	876	1130	1650	1980	2650	3460	4380	5460	6640	7880	9130	10400	11300	11800	11800
24"	600	136	580	955	1260	1620	2380	2850	3820	4990	6310	7860	9570	11300	13100	14900	16200	17100	17100
28"	700	199	844	1390	1840	2360	3450	4150	5560	7260	9190	11400	13900	16500	19100	21700	23600	24800	24800
30"	750	232	986	1620	2150	2750	3880	4840	6490	8480	10700	13400	16300	19300	22400	25400	27500	29000	29000
32"	800	261	1110	1620	2420	3100	4440	5450	7310	9550	12100	15000	18300	21700	25200	28600	31000	32600	32600
36"	900	332	1410	2320	3070	3940	5450	6930	9300	12100	15400	19100	23300	27600	32000	36300	39400	41500	41500
40"	1000	399	1700	2790	3690	4740	7210	8330	11200	14600	18400	23000	28000	33200	38400	43600	47400	49900	49900
42"	1050	457	1940	3200	4230	5430	7610	9540	12800	16700	21100	26300	32000	38000	44000	50000	54200	57100	57100
48"	1200	480	2040	3360	4440	5700	10100	10000	13400	17500	22200	27700	33700	39900	46300	52500	57000	60000	60000

Cv CURVE

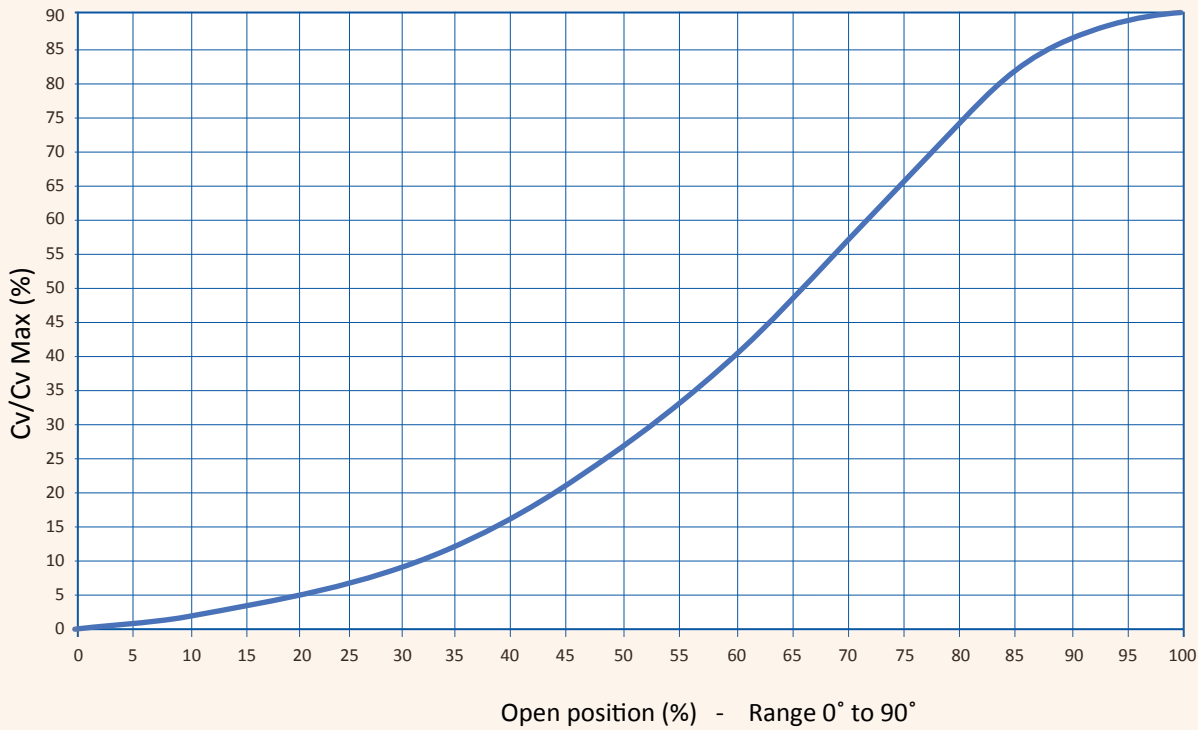

$$Q = Cv \sqrt{\frac{\Delta p}{G_L}}$$

Where:
 Q = Flow in gpm
 Δp = Pressure drop through the valve (psi)
 G_L = Specific Gravity (for water at 60°F = 1)

b. Torque Values

unit: Nm

Size		Pressure		
NPS	DN	285 PSI	740 PSI	1480 PSI
3"	80	174	271	460
4"	100	250	395	834
5"	125	283	548	979
6"	150	473	825	2938
8"	200	674	1503	3616
10"	250	983	1887	5649
12"	300	2022	2508	11863
14"	350	2520	4158	14123
16"	400	3175	6271	17061
18"	450	4239	7664	21015
20"	500	5531	10361	16551
24"	600	6011	17559	38415
30"	750	12654	33105	-
36"	900	18078	52877	-
42"	1050	24857	80219	-
48"	1200	36155	-	-

🇨🇦 Not including safety factor

c. Pressure and Temperature Ratings (ASME B16.34)

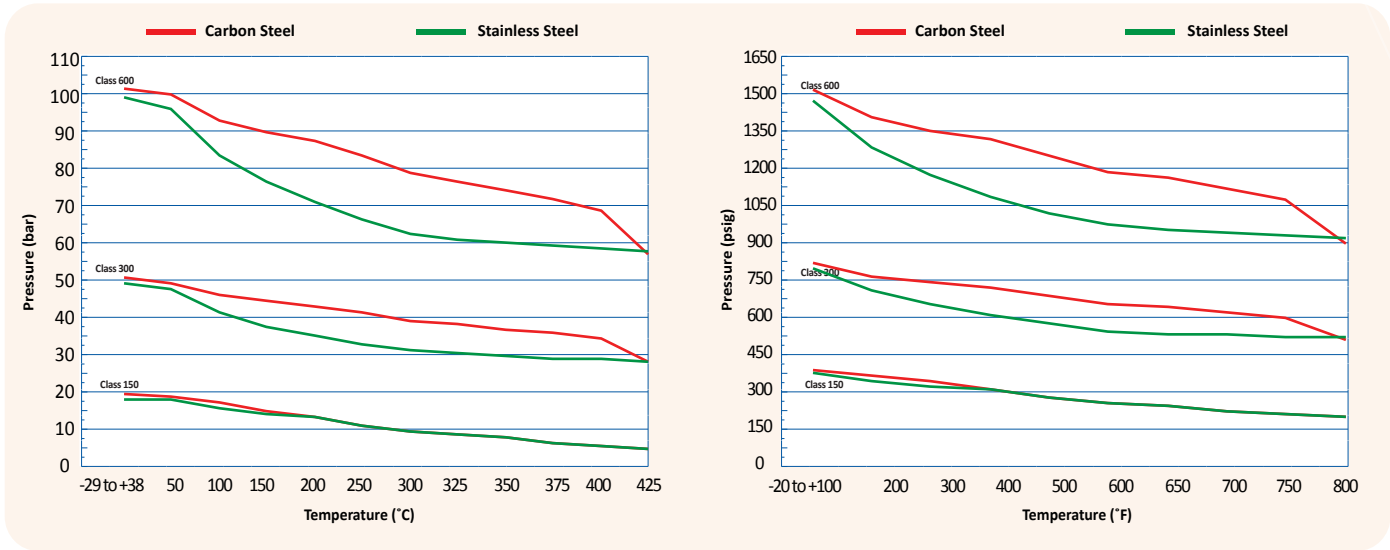

Unit: bar

Temperature (°C)	Carbon Steel A216 Gr. WCB			Stainless Steel A351 Gr. CF8M		
	Class Rating					
	150	300	600	150	300	600
-29 to 38	19.6	51.1	102.1	19.0	49.6	99.3
50	19.2	50.1	100.2	18.4	48.1	96.2
100	17.7	46.6	93.2	16.2	42.2	84.4
150	15.8	45.1	90.2	14.8	38.5	77.0
200	13.8	43.8	87.6	13.7	35.7	71.3
250	12.1	41.9	83.9	12.1	33.4	66.8
300	10.2	39.8	79.6	10.2	31.6	63.2
325	9.3	38.7	77.4	9.3	30.9	61.8
350	8.4	37.6	75.1	8.4	30.3	60.7
375	7.4	36.4	72.7	7.4	29.9	59.8
400	6.5	34.7	69.4	6.5	29.4	58.9
425	5.5	28.8	57.5	5.5	29.1	58.3

Unit: psig

Temperature (°F)	Carbon Steel A216 Gr. WCB			Stainless Steel A351 Gr. CF8M		
	Class Rating					
	150	300	600	150	300	600
-20 to 100	285	740	1480	275	720	1440
200	260	680	1360	235	620	1240
300	230	655	1310	215	560	1120
400	200	635	1265	195	515	1025
500	170	605	1205	170	480	955
600	140	570	1135	140	450	900
650	125	550	1100	125	440	885
700	110	530	1060	110	435	870
750	95	505	1015	95	425	855
800	80	410	825	80	420	845

PRODUCT SELECTION

VT - TOBF - XX - F - XX - XX - XX - XX - XX - X

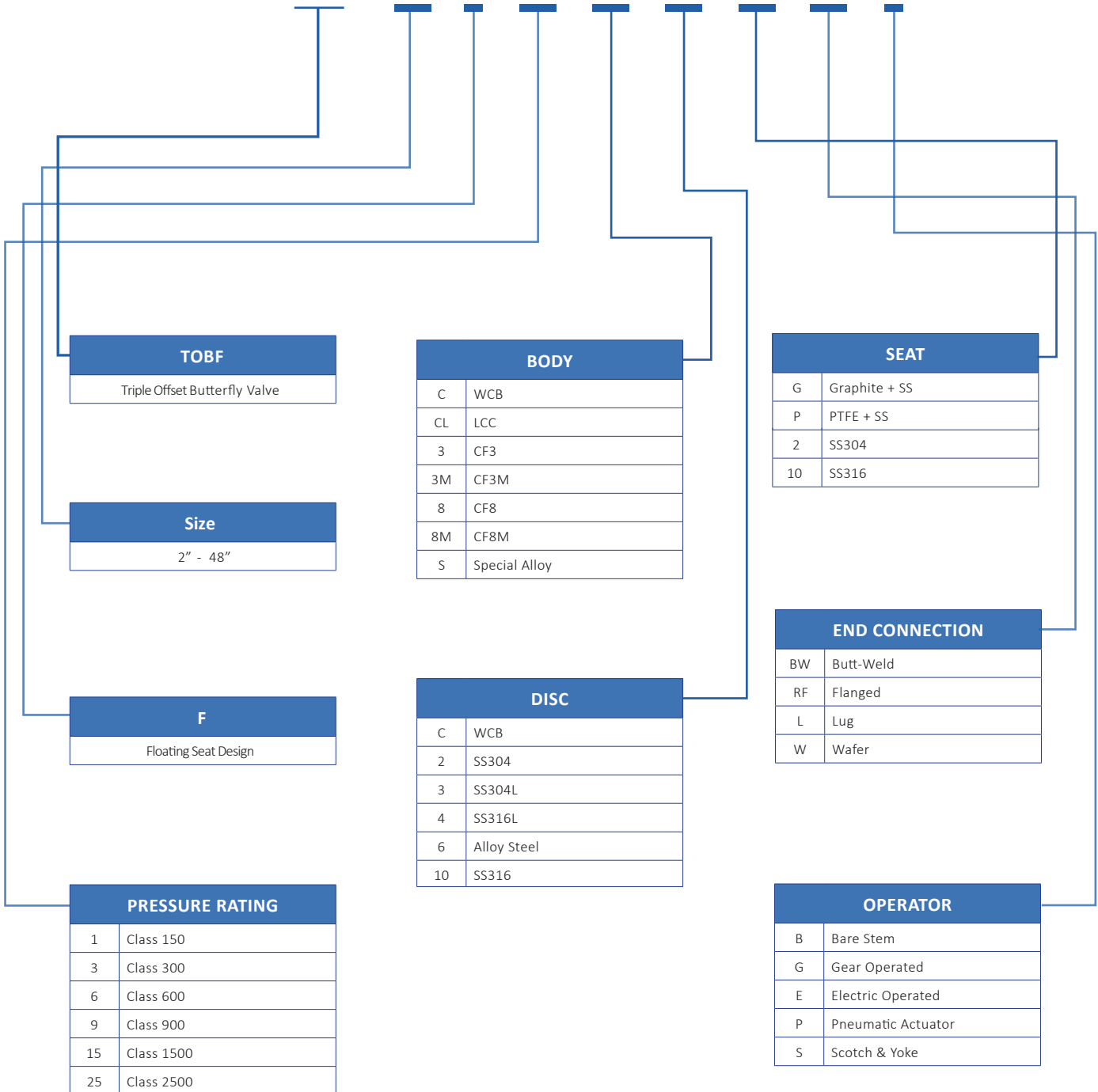



VAHN-TECH International Inc.

2608-88, Bluejays Way, Toronto, Ontario, M5V 0L7, Canada
Tel.: +1 416 342 0001 E-mail: info@vahn-tech.com

www.vahn-tech.com