

MODEL 964

PNEUMATIC CONTROL VALVE



MODEL 964
Model C27 Actuator
(ATO-FC Action)

OVERVIEW

The Model 964 is a globe-style, pneumatic control valve for general plant utility services. The design incorporates characterized trim for most pressure, temperature, level or flow applications. Standard metal seat design gives Class IV shutoff; also available in TFE soft seat design for Class VI shutoff. Available in sizes 1/2" through 3" (DN 15 through DN 80).

FEATURES

- Quick change trim
- Equal percentage trim characterization
- Metal seat or TFE soft seat designs
- Optional stellite metal seating surfaces
- Standard stainless steel trim
- Full or reduced orifice trim
- Field reversible fail safe action
- Stem position indicator
- Standard Actuator compliant with IEG 60534-6-1 or mounting standardized positioners.

APPLICATIONS

General service utility fluids including air, water, industrial gases, and steam.



LINE SIZES AVAILABLE

1/2" (DN15), 3/4" (DN20), 1" (DN25), 1-1/2" (DN40), 2" (DN50), 3" (DN80)



END CONNECTIONS

NPT, FLANGED, SOCKET WELD



COMMON APPLICATIONS

AIR, WATER, INDUSTRIAL GASES, STEAM



DESIGN PRESSURE

BETWEEN 80 - 740 psig (5.5 - 51.1 Barg)

GENERAL SPECIFICATIONS

Body Sizes:	1/2"- 1", 1-1/2", 2", and 3". (DN15 - 25, 40, 50, and 80).	Actuator/Bench Setting:	Spring diaphragm type. Field reversible. See Table 3 for proper selection of required bench setting.
Seat Design:	Metal or TFE soft seat designs with full or reduced orifice, all sizes.	Painting:	<u>Standard</u> – All external non-stainless steel surfaces are coated with corrosion resistant epoxy paint per Cashco Spec #S-1606. Fasteners are zinc plated.
Seat Leakage:	Meets ANSI/FCI 70-2013. Standard – Metal seated, Class IV. Optional – TFE soft seated, Class VI, with metal-to-metal backup.	Gaskets:	<u>Standard</u> – Spiral wound SST with carbon filler.
Flow Direction:	<u>Standard:</u> Flow-To-Open (FTO); required to maintain flow characteristic.	Trim:	SST – See Table 6 for detailed material identification.
Rangeability:	See Table 9.	Packing Flange Bolting:	Type 18-8 SST studs and nuts.
Inherent Flow Characteristic:	Equal Percentage; FTO direction only.	Packing:	V-Ring TFE live loaded packing.
Flow Capacity:	Up to 90 Cv. See Table 9.	Miscellaneous Materials:	See Table 6.

ACTUATOR SUB-ASSEMBLY SPECIFICATIONS

Action:	<u>Air-To-Open, Fail Close.</u> Increase loading pressure pushes stem up, plug opens. <u>Air-To-Close, Fail Open.</u> Increase loading pressure pushes stem down, plug closes.	Ambient Temperature:	-50 to +180°F (-45 to +83°C). -20 to +140°F (-28 to +60°C) with electrical accessories.
----------------	---	-----------------------------	--

OPTION SPECIFICATIONS

Option-3:	<u>MANUAL HANDWHEEL.</u> Overrides the actuator spring force to allow manual stroking of valve. Single acting design, side-mounted. For <u>ATO-FC</u> action, handwheel operator "opens" the plug against spring force; may be utilized as a travel stop to prevent full closure. For <u>ATC-FQ</u> action, handwheel operator "closes" the plug against spring force; may be utilized as an "up" travel stop to prevent full opening. NOTE: <i>Not available with C110 Actuator.</i>	Option-15:	<u>STELLITED TRIM.</u> For metal seated trim design only. Plug and seat seating surfaces are Stellite #6 material. Recommended for flashing or partially cavitating liquid service, or where extended time periods of ON-OFF or low flow (less than 10% open) operation occur and Class IV shutoff is required.
Option-12:	<u>REDUCED ORIFICE.</u> For reducing the maximum flow rate or for handling higher pressure drops than the full port orifice.	Option-56:	<u>SPECIAL CLEANING.</u> Special cleaning per Cashco Specifications #S-1542. Suitable for fluids other than oxygen.

MOUNTED ACCESSORY SPECIFICATIONS

Positioners: ***NOTE:** PMV Positioners are not FM Approved at this time. If you need FM Approval, please specify the Siemens PS2.*

General: PMV Positioners. Aluminum housing with corrosion resistant powder coated epoxy. Pneumatic output load as required by actuator bench range. Field reversible action. Mounting dimensions per IEC 60534-6-1 Standard.

P/P Pneumatic. Model P5 features:

- SST cam with a simple cam locking device
- Tapped exhaust port for venting media
- External zero adjustment
- Input signal 3-15 psig
- Includes gauge ports, no gauges
- Analog only.
- Nitrile, NBR -4° to +185°F

I/P Electro-Pneumatic. Model D20 features:

- Digital or Hart compatible
- Single button self-calibration
- Input signal 4-20mA
- Optional gauge block with gauges for Models D20 D and D20 A.

Model D20 D is general purpose.

Model D20 A is Intrinsically safe, Ex ia ATEX.

Model D20 E is ATEX EEX d IIB+H₂, T6 FM Approved. - **Approval Pending** Gauge block is built in, no gauges. Not available with limit switch option.

Standard PMV setup offered by Cashco:

- Single Acting
- PMV, Black Cover with Arrow Indicator
- Standard Temperature: -4°F to 185°F (-20°C to 85°C)

Model D3 Digital, Hart, Profibus, or Fieldbus compatible. Input signal 4-20mA. Features large graphic display. Optional gauge block for Models D3 X and D3 I, no gauges.

Model D3 X is general purpose.

Model D3 I is Intrinsically safe, ATEX EEX ia IIC T4.

Model D3 E is ATEX EEX d IIB+H₂, T6 CSA CLS 1 DIV 1 Not available with limit switch option.

FM CLS 1 DIV 1 - **Approval Pending** Gauge block is built in, no gauges.

Standard PMV setup offered by Cashco:

- Single Acting
- PMV, Black Cover with Arrow Indicator
- No pressure sensors, NBR -40 to +80°C

Model PS2 is Digital, Hart, Fieldbus and Profibus compatible. Input signal 4-20mA. Features a Makrolon housing, (Aluminum for Explosion Proof.) Mounting dimensions per IEC 60534-6-1 Standard.

Model PS2-1 is general purpose.

Model PS2-2 is Intrinsically safe, ATEX Ex ia IIC T6/T4, FM CLS 1 DIV 1, CSA CLS 1 DIV 1, SIL 2

Model PS2-3 EX d IIC T6/T4, SIL 2 Not available with limit switch option.

Air Tubing:

Instrument air tubing SST with SST fittings.

Airset:

Model 5200P instrument air supply regulator. Use with positioners. Bracket mounted to actuator casing. Supplied with gauge. See technical bulletin 5200P-TB.

Solenoid Valve:

Standard Brass: Available in standard weather-proof model. Brass body, 1/4" female NPT connections. Nipple mounted to actuator casing. 120 VAC, 60 Hz power supply, CSA Approved Class 3221-01, NEMA 2,3,3S,4,4X. 8" HF utilizes a direct mount NAMUR mount style.

X-Proof or SST construction: Consult Factory.

Standard installation vents actuator and drives valve to fail-safe position upon loss of electrical power.

Consult factory for 230/1/50, or 120 VDC power supplies, or intrinsically safe (IS) service.

Transducers:

FM, CSA approved NEMA 4X CI 1, Div 1 and CI 1, Div 2.

Other Accessories:

764 P/PD pressure controller. Lockup valve. Position transmitter.

Limit Switches:

Model D20 and D3 positioners, switches are available, unit is enclosed in the positioner housing.

Limit and proximity switch options not available on Explosion proof rated positioners.

**METAL SEAT
ATC-FO ACTION**

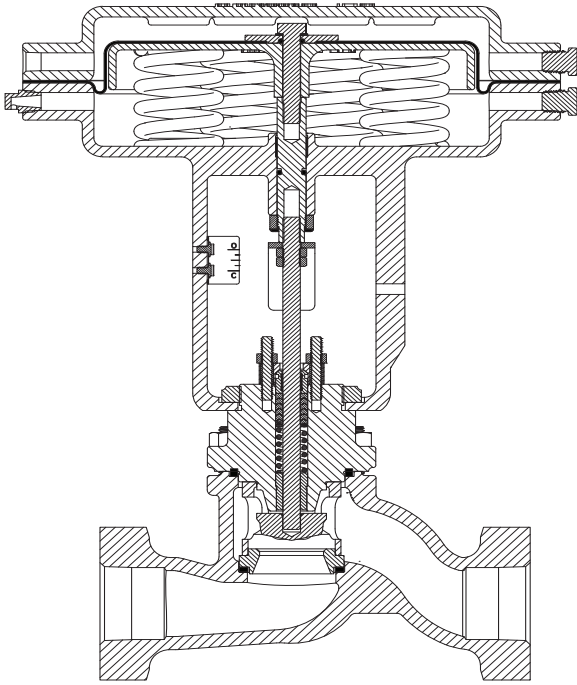

**SOFT SEAT
ATO-FC ACTION**

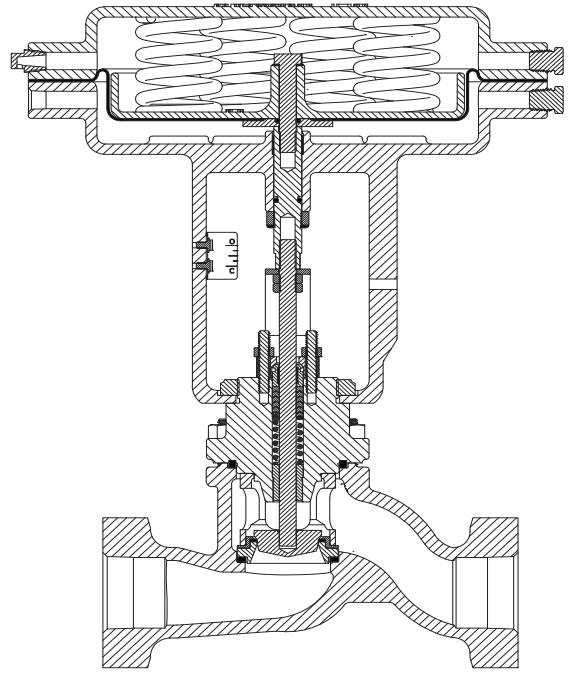

TABLE 1 - STEM - TRIM SIZE

LINE SIZE	PORT SIZE	TRIM	ORIFICE SIZE		STROKE		STEM DIAMETER		STEM THREAD SIZE
			INCH	(mm)	INCH	(mm)	INCH	(mm)	
1/2" - 1" (DN15-25)	FULL	S1/S3	0.813	(20.7)	0.50	(12.70)	0.375	(9.50)	3/8"-24 UNF
	OPT-12 REDUCED		0.500	(12.7)					
1-1/2" (DN40)	FULL	S1/S3	1.375	(34.9)	0.75	(19.10)	0.625	(15.90)	3/8"-24 UNF
	OPT-12 REDUCED		0.813	(20.7)					
2" (DN50)	FULL	S1/S3	1.938	(49.2)	0.75	(19.10)	0.625	(15.90)	3/8"-24 UNF
	FULL	S2/S4	1.750	(44.5)	1.25	(31.80)			1/2"-20 UNF
	OPT-12 REDUCED	S1/S3	1.375	(34.9)	0.75	(19.10)			3/8"-24 UNF
	OPT-12 REDUCED	S2/S4	1.250	(31.8)	1.25	(31.80)			1/2"-20 UNF
3" (DN80)	FULL	S2/S4	2.500	(63.5)	1.25	(31.80)	0.625	(15.90)	1/2"-20 UNF
	OPT-12 REDUCED		1.750	(44.5)					

TABLE 2 - ACTUATOR DISPLACEMENT

ACTUATOR MODEL	DIAPHRAGM AREA		NOMINAL STROKE		DISPLACEMENT	
	in ²	cm ²	in	(mm)	in ³	cm ³
	C27	32	206	0.50	(12.70)	16.00
0.75				(19.05)	23.04	(392.43)
C53	53	342	0.50	(12.70)	26.50	(434.34)
			0.75	(19.05)	39.75	(651.51)
C110	110	710	0.75	(19.05)	82.50	(1352.55)
			1.25	(31.75)	137.50	(2254.25)

TABLE 3 - BENCH RANGES & OPERATING PRESSURES

BENCH SET		AIR PRESSURES			
		NORMAL SUPPLY		DESIGN MAXIMUM	
PSIG	(BARG)	PSIG	(BARG)	PSIG	(BARG)
5-15	(0.34-1.03)	20	(1.4)	80	(5.5)
15-60	(1.03-4.14)	75	(5.2)	80	(5.5)

No springs available for split ranges. A positioner is required for split range input signal.

TABLE 4 - ACTUATOR MATERIAL

PART	MATERIAL
UPPER CASE	ASTM A352 LCC
LOWER CASE	
DIAPHRAGM PLATE	
CAP SCREWS	SAE J429 GRD 5
NUTS	SAE J995 GRD 5
ACTUATOR STEM	ASTM A479
ACTUATOR STEM BOLT	
ACCESSORY PLATE	
DIAPHRAGM WASHER	
DIAPHRAGM	BUNA-N/POLYESTER
O-RING	BUNA-N
LOCK WASHER	ASTM A1011
MACHINE SCREW	18-8 SST
NYLON LOCK NUT	
BUSHING	PTFE/MULTIFIL 427
VENT PLUG	NYLON
PIPE PLUG	ASTM A105
SPRING	ASTM A228 TYPE 1
INDICATOR PLATE	ASTM A240

TABLE 5 - VALVE BODY PRESSURE/TEMPERATURE RATINGS

BODY/BONNET MATERIALS		END CONNECTION	U.S. CUSTOMARY		METRIC			
			PSIG	°F	BARG	(°C)		
DUCTILE IRON (DI)	ASTM A395 60-40-18	NPT	400	-20 to 150	(27.6)	(-29 to 66)		
			370	200	(25.0)	(100)		
			340	250	(23.1)	(125)		
			310	300	(21.2)	(150)		
			300	350	(19.4)	(175)		
			250	400	(17.5)	(200)		
		CLASS 125 FF FLANGED	200	-20 to 150	(13.8)	(-29 to 65)		
			190	200	(13.1)	(93)		
			180	225	(12.4)	(107)		
			175	250	(12.0)	(121)		
			170	275	(11.7)	(135)		
			165	300	(11.3)	(149)		
			155	325	(10.6)	(163)		
			150	350	(10.3)	(177)		
			145	375	(10)	(191)		
			140	400	(9.6)	(204)		
			130	425	(8.9)	(218)		
			125	450	(8.6)	(232)		
		CLASS 250 RF FLANGED	500	-20 to 150	(34.5)	(-29 to 65)		
			460	200	(31.7)	(93)		
			440	225	(30.3)	(107)		
			415	250	(28.6)	(121)		
			395	275	(27.2)	(135)		
			375	300	(25.8)	(149)		
			355	325	(24.4)	(163)		
			335	350	(23.1)	(177)		
			315	375	(21.7)	(191)		
			290	400	(20.0)	(204)		
			270	425	(18.6)	(218)		
			250	450	(17.2)	(232)		
			CARBON STEEL (CS)	ASTM A216 GRADE WCB	NPT OR SOCKET WELD	740	-20 to 100	(51.1)
		695				200	(47.9)	(93)
		670				300	(46.2)	(149)
650	400	(44.8)				(204)		
685	500	(47.2)				(260)		
645	600	(44.4)				(316)		
580	700	(40.0)				(371)		
410	800	(28.8)				(425)		
CLASS 150 RF FLANGED	285	-20 to 100				(19.6)	(-29 to 38)	
	260	200				(17.9)	(93)	
	230	300			(15.8)	(149)		
	200	400			(13.7)	(204)		
	170	500			(11.7)	(260)		
	140	600			(9.6)	(316)		
	110	700			(7.5)	(371)		
	80	800			(5.5)	(425)		
CLASS 300 RF FLANGED	740	-20 to 100			(51.1)	(-29 to 38)		
	680	200			(46.8)	(93)		
	655	300			(45.1)	(149)		
	635	400			(43.7)	(204)		
	605	500			(41.7)	(260)		
	570	600			(39.3)	(316)		
	530	700			(36.5)	(371)		
	410	800			(28.8)	(425)		

1) Ductile iron NPT ratings per ASME B16.4-2016.
 2) Ductile iron flanged ratings per ASME B16.1-2015.
 3) Steel NPT, socket weld, and flanged ratings per ASME B31.3-2018.

TABLE 6 - TRIM MATERIALS						
Part	S1 (METAL)	S1 (OPT-15) (METAL)	S2 (METAL)	S2 (OPT -15) (METAL)	S3 (SOFT)	S4 (SOFT)
GUIDE BUSHING	ASTM A276 S21800 OR ASTM A564 17-4PH					
BUSHING	RULON 123					
CAGE	ASTM A351 CF3M OR ASTM A351 CF8M					
PACKING FLANGE	ASTM A479 316/316L					
PACKING FOLLOWER	ASTM A479 316/316L					
SPRING	ASTM A313 S17700					
WASHER	ASTM A479 316/316L					
PACKING SET	PTFE					
RETAINING RING	ASTM A564 PH 15-7 MO SST					
STOP	ASTM A582 303					
SEAT RING	ASTM A479 316/316L	STELLITE #6B	ASTM A582 416	STELLITE #6B	ASTM A479 316/316L	ASTM A582 416
PLUG/VALVE SEAT	ASTM A479 316/316L	STELLITE #6B	ASTM A564	ASTM A479 316/316L	ASTM A479 316/316L	PTFE
STEM	ASTM A479 316/316L	ASTM A479 316/316L	ASTM A564	ASTM A564	ASTM A479 316/316L	ASTM A564
ADAPTER (UPPER & LOWER)	--	--	--	--	--	ASTM A582 303
CASTLE NUT	--	--	--	--	--	18-8 SST
COTTER PIN	--	--	--	--	--	18-8 SST
BONNET GASKET	304 SST/GRAPHITE	304 SST/GRAPHITE	304 SST/GRAPHITE	304 SST/GRAPHITE	304 SST/GRAPHITE	304 SST/GRAPHITE
SEAT RING GASKET	304 SST/GRAPHITE	304 SST/GRAPHITE	304 SST/GRAPHITE	304 SST/GRAPHITE	304 SST/GRAPHITE	304 SST/GRAPHITE
SEAT INSERT	--	--	--	--	PTFE	--
SEAT RETAINER	--	--	--	--	ASTM A479 316/316L	--

TABLE 7 - BODY MATERIALS						
LINE SIZE	MATERIAL	BODY	BONNET	FLANGE	STUD/HCS	HEX NUT
1/2"	DUCTILE IRON	ASTM A395 60-40-18	ASTM A395 60-40-18	N/A	ASTM A193 B7	ASTM A194 2H
	CARBON STEEL	N/A	N/A	N/A	N/A	N/A
3/4"	DUCTILE IRON	ASTM A395 60-40-18	ASTM A395 60-40-18	N/A	ASTM A193 B7	ASTM A194 2H
	CARBON STEEL	ASTM A216 WCB	ASTM A216 WCB	ASTM A216 WCB	ASTM A193 B7	ASTM A194 2H
1"	DUCTILE IRON	ASTM A395 60-40-18	ASTM A395 60-40-18	N/A	ASTM A193 B7	ASTM A194 2H
	CARBON STEEL	ASTM A216 WCB	ASTM A216 WCB	ASTM A216 WCB	ASTM A193 B7	ASTM A194 2H
1-1/2"	DUCTILE IRON	ASTM A395 60-40-18	ASTM A395 60-40-18	N/A	ASTM A193 B7	ASTM A194 2H
	CARBON STEEL	ASTM A216 WCB	ASTM A216 WCB	ASTM A216 WCB	ASTM A193 B7	ASTM A194 2H
2"	DUCTILE IRON	ASTM A395 60-40-18	ASTM A216 WCB	N/A	ASTM A193 B7	ASTM A194 2H
	CARBON STEEL	ASTM A216 WCB	ASTM A216 WCB	ASTM A516 GR. 70	ASTM A193 B7	ASTM A194 2H
3"	DUCTILE IRON	ASTM A395 60-40-18	ASTM A216 WCB	N/A	ASTM A193 B7	ASTM A194 2H
	CARBON STEEL	ASTM A216 WCB	ASTM A216 WCB	ASTM A105	ASTM A193 B7	ASTM A194 2H

**TABLE 8 - MAXIMUM PRESSURE DROP - PSID (BARD)
CLASS IV SEAT LEAKAGE FOR METAL SEATED; CLASS VI SEAT LEAKAGE FOR COMPOSITION SEATED
SHUTOFF PRESSURES MAY BE FURTHER DERATED BY MAWP**

LINE SIZE	PORT SIZE	ORIFICE SIZE		ACTUATOR			DIRECT ATO-FC & REVERSE ATC-FO			
				MODEL NO.	BENCH RANGE		METAL SEAT		COMP SEAT	
		INCH	(mm)		PSIG	(BARG)	PSID	(BARD)	PSID	(BARD)
1/2" - 1" (DN25)	FULL	0.813	(20.7)	C27	5-15	(0.34-1.03)	96	(6.6)	194	(13.4)
					15-60	(1.03-4.14)	682	(47.0)	740	(51.0)
				C53	5-15	(0.34-1.03)	288	(19.9)	387	(26.7)
					15-60	(1.03-4.14)	740	(51.0)	740	(51.0)
	OPT-12 REDUCED	0.500	(12.7)	C27	5-15	(0.34-1.03)	454	(31.3)	614	(42.3)
					15-60	(1.03-4.14)	740	(51.0)	740	(51.0)
				C53	5-15	(0.34-1.03)	740	(51.0)	740	(51.0)
					15-60	(1.03-4.14)	740	(51.0)	740	(51.0)
1-1/2" (DN40)	FULL	1.375	(34.9)	C27	5-15	(0.34-1.03)	N/A	N/A	CF	CF
					15-60	(1.03-4.14)	191	(13.2)	249	(17.2)
				C53	5-15	(0.34-1.03)	53	(3.7)	111	(7.7)
					15-60	(1.03-4.14)	392	(27.0)	450	(31.1)
	OPT-12 REDUCED	0.813	(20.7)	C27	5-15	(0.34-1.03)	96	(6.6)	194	(13.4)
					15-60	(1.03-4.14)	682	(47.0)	740	(51.0)
				C53	5-15	(0.34-1.03)	288	(19.9)	387	(26.7)
					15-60	(1.03-4.14)	740	(51.0)	740	(51.0)
2" (DN50)	FULL	1.938	(49.2)	C27	5-15	(0.34-1.03)	N/A	N/A	CF	CF
					15-60	(1.03-4.14)	72	(5.0)	113	(7.8)
				C53	5-15	(0.34-1.03)	CF	CF	CF	CF
					15-60	(1.03-4.14)	173	(12.0)	215	(14.8)
		C110	5-15	(0.34-1.03)	95	(6.5)	136	(9.4)		
			15-60	(1.03-4.14)	449	(30.9)	490	(33.8)		
			C110	5-15	(0.34-1.03)	126	(8.7)	172	(11.8)	
				15-60	(1.03-4.14)	560	(38.6)	606	(41.8)	
	OPT-12 REDUCED	1.375	(34.9)	C27	5-15	(0.34-1.03)	N/A	N/A	CF	CF
					15-60	(1.03-4.14)	191	(13.2)	249	(17.2)
				C53	5-15	(0.34-1.03)	53	(3.7)	111	(7.7)
					15-60	(1.03-4.14)	392	(27.0)	450	(31.1)
		C110	5-15	(0.34-1.03)	236	(16.2)	294	(20.2)		
			15-60	(1.03-4.14)	740	(51.0)	740	(51.0)		
			C110	5-15	(0.34-1.03)	298	(20.5)	362	(24.9)	
				15-60	(1.03-4.14)	740	(51.0)	740	(51.0)	
3" (DN80)	FULL	2.500	(63.5)	C110	5-15	(0.34-1.03)	CF	CF	74	(5.1)
					15-60	(1.03-4.14)	255	(17.6)	287	(19.8)
	OPT-12 REDUCED	1.750	(44.5)	C110	5-15	(0.34-1.03)	126	(8.7)	172	(11.8)
					15-60	(1.03-4.14)	560	(38.6)	606	(41.8)

- 1) CF = Consult Factory where differential pressures are below 50 psid preventing seat leakage evaluation per Cashco S-1597 at 50 psid.
- 2) Excessive differential pressures have been derated to a maximum of 740 psid (51.0 barg) corresponding with WCB body material with NPT or Class 300 flanged end connections at ambient conditions. Further derating may be necessary based on valve body pressure/temperature ratings.
- 3) ATC-FO values for 5-15 psig bench range based on maximum 20 psig (1.4 barg) supply pressure with use of a positioner.
ATC-FO values for 15-60 psig bench range based on maximum 75 psig (5.2 barg) supply pressure with use of a positioner.

TABLE 9 - VALVE FLOW CAPACITY; $F_L = 0.90$

LINE SIZE	PORT SIZE	TRIM	MINIMUM Cv	Cv AT 10% INCREMENTS									
				10%	20%	30%	40%	50%	60%	70%	80%	90%	100%
1/2" (DN15)	FULL	S1	0.15	0.4	0.7	1.1	1.5	2.2	3.1	4.0	5.0	6.2	7.4
		S3	0.15	0.4	0.7	1.0	1.5	2.1	2.9	4.1	5.0	6.2	7.4
	OPT-12 REDUCED	S1	0.08	0.2	0.2	0.4	0.5	0.8	1.1	1.6	2.3	3.2	4.1
		S3	0.08	0.2	0.2	0.4	0.5	0.8	1.1	1.7	2.3	3.3	4.1
3/4" (DN20)	FULL	S1	0.15	0.4	0.7	1.1	1.6	2.3	3.3	4.7	6.3	7.9	9.3
		S3	0.15	0.4	0.7	1.0	1.5	2.2	3.1	4.8	6.4	8.1	9.6
	OPT-12 REDUCED	S1	0.08	0.2	0.2	0.4	0.5	0.8	1.1	1.7	2.4	3.3	4.4
		S3	0.08	0.2	0.2	0.4	0.5	0.8	1.1	1.7	2.4	3.5	4.5
1" (DN25)	FULL	S1	0.20	0.4	0.7	1.1	1.6	2.3	3.4	4.9	6.7	8.9	10.7
		S3	0.20	0.4	0.7	1.0	1.5	2.2	3.1	5.0	6.8	8.8	10.7
	OPT-12 REDUCED	S1	0.09	0.2	0.2	0.4	0.5	0.8	1.1	1.7	2.4	3.5	4.5
		S3	0.09	0.2	0.2	0.4	0.5	0.8	1.1	1.7	2.4	3.5	4.5
1-1/2" (DN40)	FULL	S1	0.40	1.0	1.7	2.7	4.2	6.1	8.5	11.5	14.6	17.6	20.5
		S3	0.40	0.9	1.7	2.7	4.1	6.0	8.4	11.3	14.3	17.3	20.3
	OPT-12 REDUCED	S1	0.20	0.3	0.6	1.0	1.6	2.5	3.8	5.3	7.1	9.2	11.3
		S3	0.20	0.3	0.5	0.9	1.4	2.2	3.2	4.5	6.1	7.9	9.7
2" (DN50)	FULL	S1	0.90	2.6	4.4	6.9	10.3	14.7	21.1	27.7	34.0	40.0	45.5
		S2	1.30	1.7	3.8	5.7	7.5	10.9	22.2	34.8	40.5	43.0	43.3
		S3	0.90	2.7	4.5	7.1	10.7	15.2	21.6	28.1	34.8	41.2	47.0
		S4	1.30	2.4	4.3	6.2	9.3	13.1	21.0	31.7	38.6	42.0	43.8
	OPT-12 REDUCED	S1	0.60	1.2	2.1	3.5	5.5	8.2	11.7	15.9	20.7	25.6	30.5
		S2	0.80	1.3	2.7	3.8	5.1	5.7	9.5	19.0	26.0	29.9	29.5
		S3	0.60	1.3	2.1	3.5	5.5	8.2	11.7	15.9	20.6	25.5	30.5
		S4	0.80	1.5	2.6	3.7	5.0	5.8	8.5	15.8	25.4	29.7	29.3
3" (DN80)	FULL	S2	2.40	3.8	7.7	11.0	19.1	39.2	56.2	70.8	79.8	85.8	90.7
		S4	2.40	3.6	7.0	11.3	21.0	38.9	52.9	65.8	76.7	84.3	90.3
	OPT-12 REDUCED	S2	1.80	1.5	3.7	5.7	6.7	11.9	30.1	48.7	60.6	66.0	67.0
		S4	1.80	1.9	4.0	6.0	8.6	13.4	27.9	45.0	56.6	62.5	65.2

DIMENSIONS AND WEIGHTS

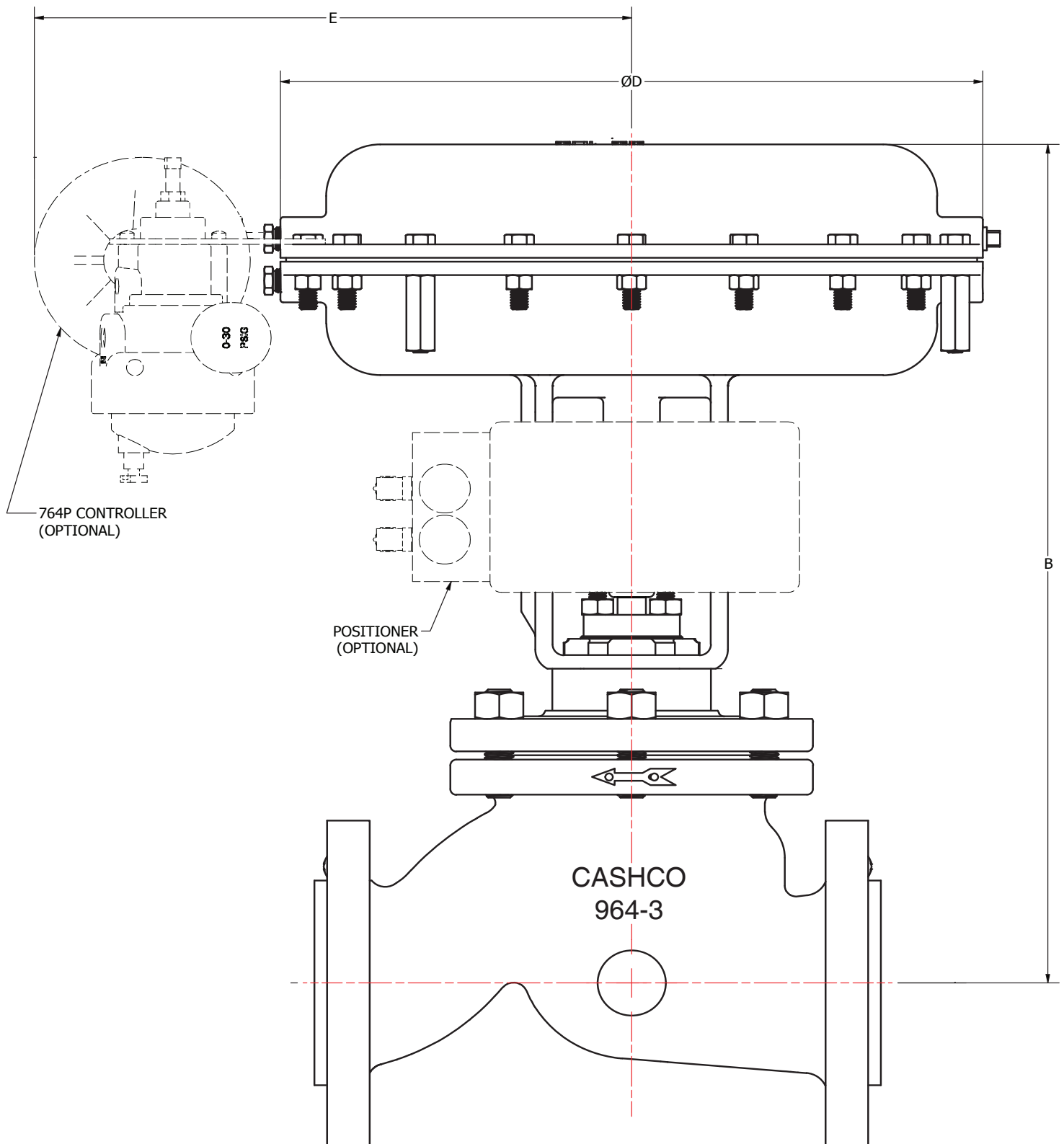

ENGLISH UNITS - INCH & LBS.

ENGLISH UNITS - INCH & LBS.						
ACTUATOR MODEL	DIMENSION	LINE SIZE				
		1/2", 3/4", & 1"	1-1/2"	2"	3"	
C27	B	13.65	14.03	16.59	NA	
	D	ø9.00				
	E	9.97				
WEIGHT		* 32	37	47	71	NA

ENGLISH UNITS - INCH & LBS.						
ACTUATOR MODEL	DIMENSION	LINE SIZE				
		1/2", 3/4", & 1"	1-1/2"	2"	3"	
C53	B	13.79	14.17	16.73	NA	
	D	ø11.56				
	E	11.21				
WEIGHT		* 42	47	57	81	156

ENGLISH UNITS - INCH & LBS.			
ACTUATOR MODEL	DIMENSION	LINE SIZE	
		2"	3"
C110	B	20.196	20.456
	D	ø15.50	
	E	13.19	
WEIGHT		116	156

METRIC UNITS - mm & kgs.

METRIC UNITS - mm & kgs.						
ACTUATOR MODEL	DIMENSION	LINE SIZE				
		1/2", 3/4", & 1"	1-1/2"	2"	3"	
C53	B	350.3	359.9	424.9	NA	
	D	ø293.6				
	E	284.7				
WEIGHT		* 19	21	25	36	70

METRIC UNITS - mm & kgs.						
ACTUATOR MODEL	DIMENSION	LINE SIZE				
		1/2", 3/4", & 1"	1-1/2"	2"	3"	
C27	B	346.7	356.4	421.4	NA	
	D	ø228.6				
	E	253.2				
WEIGHT		* 14	16	21	32	NA

METRIC UNITS - mm & kgs.			
ACTUATOR MODEL	DIMENSION	LINE SIZE	
		2"	3"
C110	B	513.0	519.6
	D	ø393.7	
	E	335.0	
WEIGHT		116	156

NOTE:

Weights listed are total valve weight with actuator, no accessories or manual operator.
 Weight is calculated with the largest end connection available.
 * = 150# & 300# Flanges not available in 1/2" size, NPT only.

DIMENSIONS AND WEIGHTS

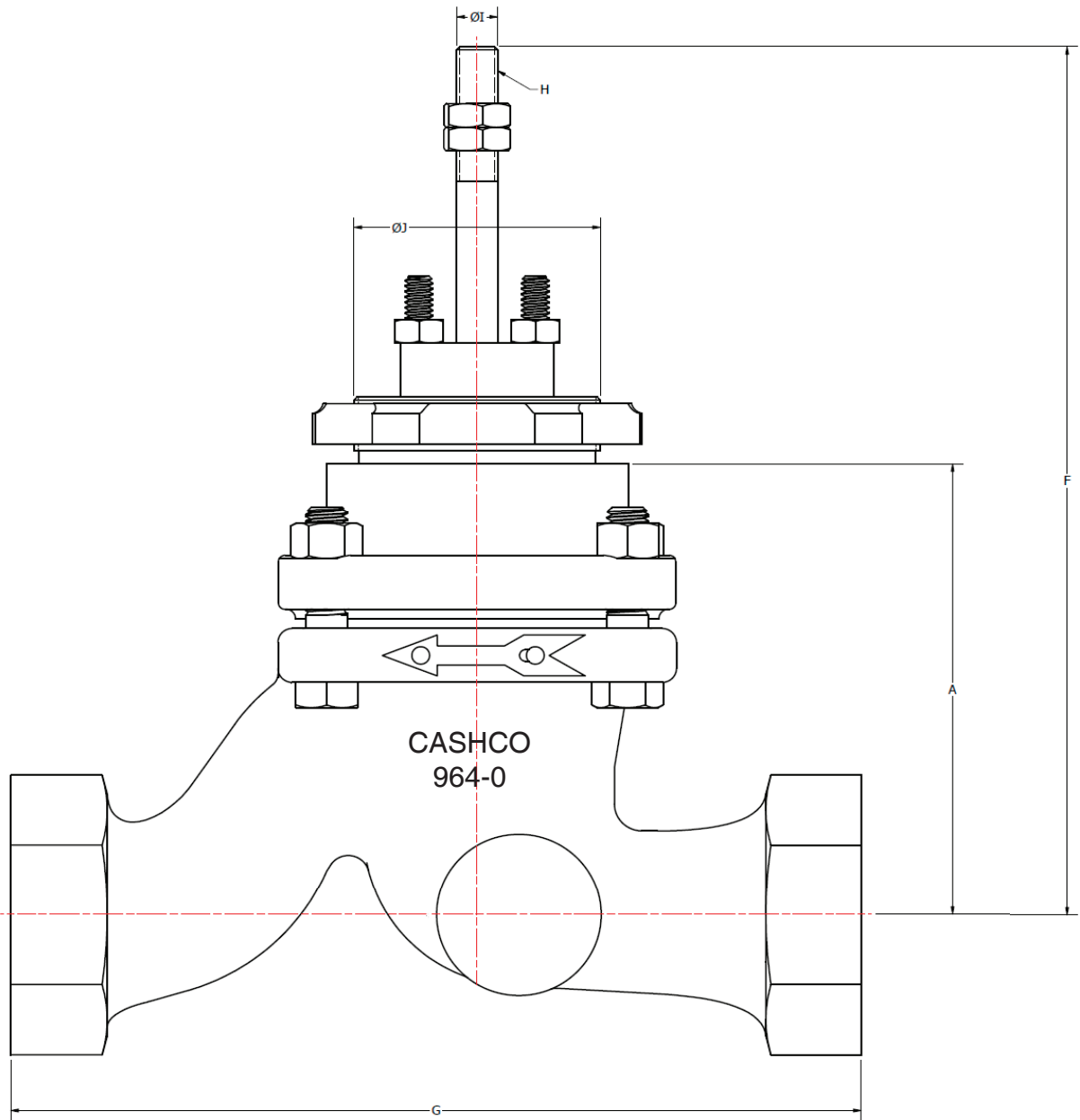

ENGLISH UNITS - INCH & LBS.						
DIMENSION	LINE SIZE					
	1/2", 3/4", & 1"	1-1/2"	2" (C27/C53)	2" (C110)	3"	
A	4.19	4.56	7.12	6.993	7.25	
F	8.06	8.45	10.91	10.89	11.14	
G F TO F	NPT/SW	7.75	9.25	10.50	10.50	^ 12.50
	125/250#	NA	9.25	10.50	10.50	12.50
	150/300#	* 7.75	9.25	10.50	10.50	12.50
H	3/8-24 UNF	3/8-24 UNF	3/8-24 UNF	1/2-20 UNF	1/2-20 UNF	
I	ø0.375	ø0.375	ø0.375	ø0.500	ø0.500	
J	ø2.25					
WEIGHT	* 12	17	29	48	49	79

METRIC UNITS - mm & kgs.						
DIMENSION	LINE SIZE					
	1/2", 3/4", & 1"	1-1/2"	2" (C27/C53)	2" (C110)	3"	
A	106.4	115.8	180.8	177.6	184.2	
F	204.7	214.6	277.1	276.6	283.0	
G F TO F	NPT/SW	196.9	235.0	266.7	266.7	^ 317.5
	125/250#	NA	235.0	266.7	266.7	317.5
	150/300#	* 196.9	235.0	266.7	266.7	317.5
H	3/8-24 UNF	3/8-24 UNF	3/8-24 UNF	1/2-20 UNF	1/2-20 UNF	
I	ø9.5	ø9.5	ø9.5	ø12.7	ø12.7	
J	ø57.2					
WEIGHT	* 5	7	13	22	22	35

NOTE:

Weight is calculated with the largest end connection available.

* = 150# & 300# Flanges not available in 1/2" size, NPT only.

^ = 3" valve not available with NPT connection.

SW = Socket Weld

MODEL 964 PRODUCT CODER 12/02/20

An "X" in POS 12 followed by a 5-digit control number overrides remaining selections.

1	6	POS 3	—	POS 5	POS 6	0	7	—	0	POS 11	POS 12	POS 13	POS 14	POS 15	POS 16	POS 17	G
----------	----------	-------	---	-------	-------	----------	----------	---	----------	--------	--------	--------	--------	--------	--------	--------	----------

POSITION 3 - SIZE & BODY MATERIAL		
Body Size	Body Material	
	DI	CS
	CODE	CODE
1/2" *	3	
3/4"	1	A
1"	2	B
1-1/2"	4	D
2"	5	E
3"	6	F

* Only available with NPT Connection.

POSITION 5 - END CONNECTIONS	
End Connection	CODE
** NPT - Screwed	1
* 125 Lb. Flgs. - DI Body	2
150 Lb. CS S.O. Flgs. - CS Body	3
* 250 Lb. Flgs. - DI Body	4
300 Lb. CS S.O. Flgs. - CS Body	5
** Socket Weld - CS Body	6

* Not available in 1/2" - 1" Sizes
** Not available in 3" Size

POSITION 6 - PORT SIZE / TRIM				
Port Size / Description	TRIM			
	Model C27-C53 1/2" - 2" Only		Model C110 2" - 3" Only	
	S1	S3	S2	S4
	CODE	CODE	CODE	CODE
Full	1	5	A	E
Opt.-12 Reduced	2	6	B	F
Full & Opt.-15 Stellite	3		C	
Opt.-12 Reduced & 15 Stellite	4		D	

POSITION 11 - ACTUATOR MODEL / BENCH SET RANGE & ACTION							
Bench Range (psig)	No Actuator	Model C27		Model C53		Model C110	
	--	ATO FC	ATC FO	ATO FC	ATC FO	ATO FC	ATC FO
	CODE						
5-15 *	0	A	1	3	5	C	E
15-60		B	2	4	6	D	F

* Consult Factory for 2" size w/ C27 Actuator or 2" Size Full Port w/ C53 Actuator.
See Table 8 for Max. Pressure Drops

POSITION 12 - 764P * (Bracket Mtd) - ADDITIONAL Airset (Bracket Mtd) & Solenoid Valves			
764P / Action	Solenoid Valve *** Exhaust on Deenergization		
	CODE		
	None	120VAC 60 Hz	24 VDC
None	0	6	C
None W/ Airset	1	7	D
Reverse	2	8	E
Reverse W/ Airset	3	9	F
Direct	4	A	G
Direct W/ Airset	5	B	H
For Special Construction Contact Cashco for Special Code	X		

* Refer to 764-TB for Product Code of Controller
*** Solenoid rated as 4/4X only.

POSITION 13 - DIRECT ACTING POSITIONER with AIRSET (Bracket Mounted) (3-15 psig) 4-20 mA Specify Split Range in Special Instructions on the P.O.					
Positioner Model	Ratings	Analog/Digital	Hart	Fieldbus	Profibus
		CODE			
P5 P/P *	Gen. Purpose	1			
D20 D I/P	Gen. Purpose	C	D		
D20 A I/P * ‡	Intrinsically Safe	2	5		
D20 E I/P *** ‡	Explosion Proof	E	F		
D3 X I/P	Gen. Purpose	L	M	N	P
D3 I I/P	Intrinsically Safe	3	6	8	A
D3 E I/P **** ‡	Explosion Proof	G	H	J	K
PS2-1 I/P	Gen. Purpose	Q	R	S	T
PS2-2 I/P	Intrinsically Safe	&	7	9	B
PS2-3 I/P ***	Explosion Proof	<	U	V	W
None **		0			

* Stock Item
** Actuator Assembly includes dimensions for (Namur) Mounting per IEC 60534-6-1.
*** D20E & PS2-3 are not available with limit/proximity switch option. Select codes "8", "9" or "0" in Pos.15.
**** D3E Positioner is not available with options. Please select code "0" in Pos. 15.
‡ PMV Positioners are not FM Approved at this time. If you need FM Approval, please specify the Siemens PS2.

POSITION 14 - GAUGE BLOCK	
Option for Positioner	Code
None *	0
Gauge Block **	1

* For P5 gauge ports built in. No gauges.
* For D20 E, D3 E & PS2-3 gauge block is standard. No gauges.
** For D20 D, D20E & D20 A and PS2-1 & PS2-2- gauge block with gauges.
** For D3 X & D3 I gauge block only - no gauges.

POSITION 15 - POSITIONER OPTIONS							
Options	POSITIONERS			I/P TRANSDUCERS *			
	1 Inductive Limit Switches (Proximity)	1 Micro Limit Switches (Mechanical)	Position Transmitter	3-15 PSIG No Airset **	3-15 PSIG W/ Airset **	0-60 PSIG No Airset ***	0-60 PSIG W/ Airset ***
	CODE						
P5				4	5		
D3 & D20 ²	7	T	9				
PS2			8				
No Positioner				C	F	R	S
None	0						

* For 0-60 Psig Transducer please contact the factory.
** If 5-15 psig Bench Range is selected in Pos. 11, codes R & S are invalid options.
*** If 15-60 psig Bench Range is selected in Pos. 11, codes 4, 5, C & F are invalid options.
¹ D20E & PS2-3 are not available with limit/proximity switch option. Choose codes "8", "9" or "0".
² D3E Positioner is not available with options. Please select code "0".

POSITION 16 - OPTIONS	
Accessories	CODE
No Handwheel	0
Handwheel *	9

* Not available with Positioner Option. Select code 0 in Pos. 13.
Model C110 is not available with a Handwheel.

POSITION 17 - PAINTING & CLEANING			
Painting	Opt.	Std. Commercial Cleaning	Cleaned to Spec. #S-1542
		CODE	
Standard	—	0	3

Cashco, Inc.
P.O. Box 6
Ellsworth, KS 67439-0006
PH (785) 472-4461
Fax. # (785) 472-3539
www.cashco.com
email: sales@cashco.com
Printed in U.S.A. 964-TB

Cashco GmbH
Handwerkerstrasse 15
15366 Hoppegarten, Germany
PH +49 3342 30968 0
Fax. No. +49 3342 30968 29
www.cashco.com
email: germany@cashco.com

Cashco do Brasil, Ltda.
Rua Bonifácio Cubas, 389.
Cep 02731-000 - Vila Albertina - São Paulo - SP
PH +55 11 99677 7177
Fax. No.
www.cashco.com
email: brazil@cashco.com